

 **QUIETSOURCE™**

Owner's Manual

Liquid-cooled, Prepackaged
Standby Generators

Model Number: 005031-2 (25kW)

This manual should remain with the unit.

—▲ CAUTION ▲—

**ONLY QUALIFIED ELECTRICIANS OR CONTRACTORS
SHOULD ATTEMPT INSTALLATION!!**

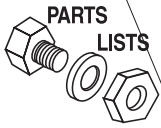

REAR BEARING
CARRIER

19

35

FOR

PLATE

15

Section 7 - Exploded Views and Parts Lists

Liquid-cooled 25 kW Generators
Mounting Base – Drawing No. 0F0104-B

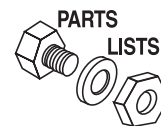

ITEM	PART NO.	QTY.	DESCRIPTION
1	0F1705	1	SUPPORT BATTERY TRAY
2	0E8834	1	HOLD DOWN BATTERY
3	0E9911	1	ASSEMBLY BATTERY TRAY
4	049813	1	NUT HEX M6 X 1.0 G8 YEL CHR
5	022097	4	WASHER LOCK M6-1/4
6	026850	2	WASHER SHAKEPROOF EXT 1/4 STL
7	055414	1	LUG SLDLSS #2-#8 X 17/64 CU
8	022473	4	WASHER FLAT 1/4-M6 ZINC
9	047411	4	SCREW HHC M6-1.0 X 16 G8.8
10	052860	4	NUT FLANGED HEX M12-1.75
11	052251	4	DAMPENER VIBRATION 40 BLUE
12	052257	4	SPACER .49 X .62 X 1.87 PWDR/ZNC
13	052252	4	DAMPENER VIBRATION
14	052259	4	WASHER FLAT M12
15	052891	4	SCREW HHC M12-1.75 X 80 G8.8
16	0536210261	1	ASSY WIRE #0 12.00"
17	074906	1	SCREW HHTT M6-1.0 X 20 BP
18	077483	REF	BATT 12VDC 75-AH 26 (NOT SHOWN)
19	0F0796	3	BRACKET CONTROL PANEL SUPPORT
20	025507	3	WASHER SHAKEPROOF EXT 7/16 STL
21	060619	1	SCREW SHC M10-1.50 X 40 G12.9
22	046526	1	WASHER LOCK M10
23	022131	1	WASHER FLAT 3/8-M10 ZINC
24	021991	1	EARTH STRAP
25	038805G	1	CABLE BATT BLK #1 X 41.50
26	050331	REF	BATTERY POST COVER (BLACK)
27	050331A	REF	BATTERY POST COVER (RED)
28	038804J	1	CABLE BATT RED #1 X 40.50
29	045771	REF	NUT HEX M8-1.25 G8 YEL CHR
30	022129	REF	WASHER LOCK M8-5/16
31	027482	1	WASHER SHAKEPROOF EXT 5/16 STL
32	075763	1	BOOT BATTERY CABLE
33	0E9748A	1	ASSY MTG BASE 2.5L AL ENCL
34	0F0795	3	SUPPORT CONTROL PANEL 2.5L
35	0C2454	33	SCREW THF M6-1 X 16 N WA Z/JS
36	065852	1	SPRING CLIP HOLDER .37-.62
37	045764	1	SCREW HHTT M4-0.7 X 8 BP

Section 7 - Exploded Views and Parts Lists

**Liquid-cooled 25 kW Generators
Enclosure – Drawing No. 0F1645-H**

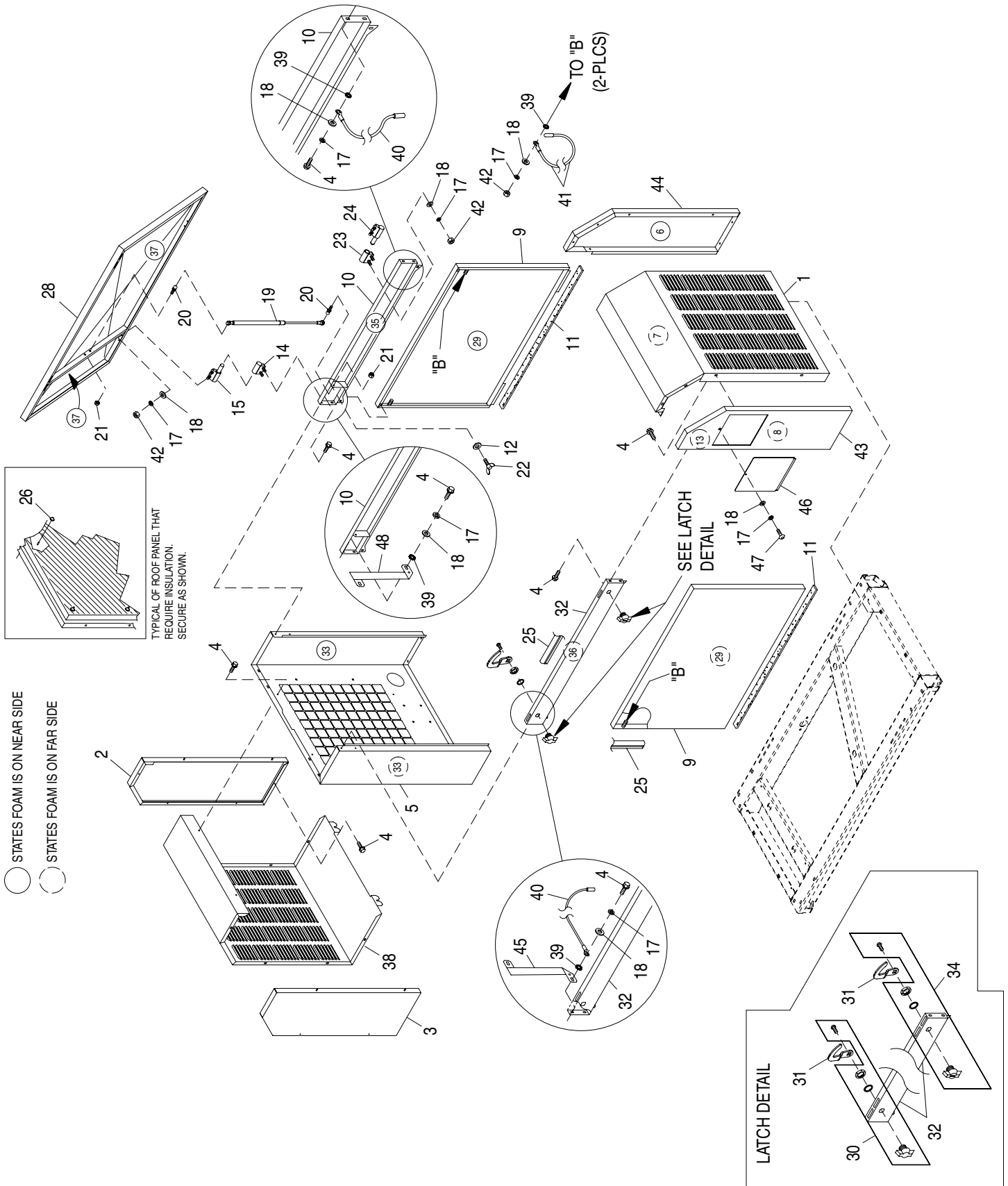

Section 7 - Exploded Views and Parts Lists

Liquid-cooled 25 kW Generators
Enclosure – Drawing No. 0F1645-H

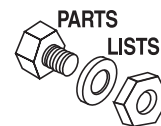

ITEM	PART NO.	QTY.	DESCRIPTION
1	0F0783	1	DUCT INTAKE MID AL 2.5L
2	0F0781	1	DUCT DISCHARGE RH AL 2.5L
3	0F0780	1	DUCT DISCHARGE LH AL 2.5L
4	0C2454	34	SCREW TH-FRM M6-1 X 16 N WA Z/JS
5	0F0779	1	SUPPORT RADIATOR 2.5L AL
6	0E0072AB	1	AI INSULATION SIDE REAR CORNER POST RH
7	0E0072AC	1	AI INSULATION INTAKE DUCT TOP PANEL
8	0E0072AD	1	AI INSULATION LH SIDE REAR CORNER POST PANEL (BOTTOM)
9	0E5912	2	DOOR SIDE HSB AL
10	0F0787	1	SUPPORT RH SIDE AL 2.5L
11	089961	2	FOAM STRIP 3/4" WIDE X 3/16" THK (40" LG)
12	0A2115	4	WASHER NYLON .257
13	0E0072AE	1	AI NSULATION LH SIDE REAR CORNER POST PANEL (TOP)
14	0F0165A	1	HINGE TYPE B W/STUDS, SOCKET
15	0F0165	1	HINGE TYPE B W/STUDS, PIN
17	022097	13	WASHER LOCK M6-1/4
18	022473	13	WASHER FLAT 1/4-M6 ZINC
19	0E7570	2	GAS SPRING
20	0E7571	4	BALL STUD GAS SPRING MOUNT
21	070015	4	NUT HEX 5/16-18 LOCK
22	0E7662	4	SCREW WING M6-1.00 X 25
23	0F0164A	1	HINGE TYPE A W/STUDS, SOCKET
24	0F0164	1	HINGE TYPE A W/STUDS, PIN
25	0D2023	3	GASKET CLIP-ON SELF GRIPPING (84" LG)
26	078115	8	WASHER SELF LOCKING DOME
27	0F2179	1	KIT SAE FOAM 2.5L QUIET SOURCE
28	0F0788	1	ROOF 2.5L FORD AL
29	0E7829B	2	AI DOOR PANEL
30	0D3037A	1	LATCH 1/4 TURN NONLOCKING
31	0C7781	2	PAWL DOOR HSB
32	0F0786	1	SUPPORT LH SIDE AL 2.5L
33	0E0072Q	2	AI INSULATION RAD SUPPORT PANEL
34	0D3037	1	LATCH QUARTER TURN LOCKING
35	0E0072Y	1	AI INSULATION SIDE BRACE PANEL RH
36	0E0072AF	1	AI INSULATION SIDE BRACE PANEL LH
37	0E0072AA	1	AI INSULATION ROOF PANEL
38	0F0782	1	DUCT DISCHARGE MID AL 2.5L
39	026850	4	WASHER SHAKEPROOF EXT 1/4 STL
40	0912970064	2	ASSY WIRE 14AWG 7.5 #0 GRN/YEL
41	0912970063	2	ASSY WIRE 14AWG 7.5 #0 GRN/YEL
42	049813	10	NUT HEX M6 X 1.0 G8 YEL CHR
43	0F0784	1	CORNER POST REAR LH SIDE AL
44	0F0785	1	CORNER POST REAR RH SIDE AL
45	0E8665	1	BRACKET STIFFENER LH FRONT
46	0E8837	1	DOOR BATTERY COMPARTMENT
47	0A3359	1	SCREW BHSC M6-1.0 X 16 SS
48	0E8404	1	BRACKET STIFFENER RH FRONT

* ALL ITEMS NOTATED WITH "AI" ARE COMPONENTS OF 0F2179

Section 7 - Exploded Views and Parts Lists

**Liquid-cooled 25 kW Generators
Control Panel (15kW and 20kW) – Drawing No. 0F2267-D**

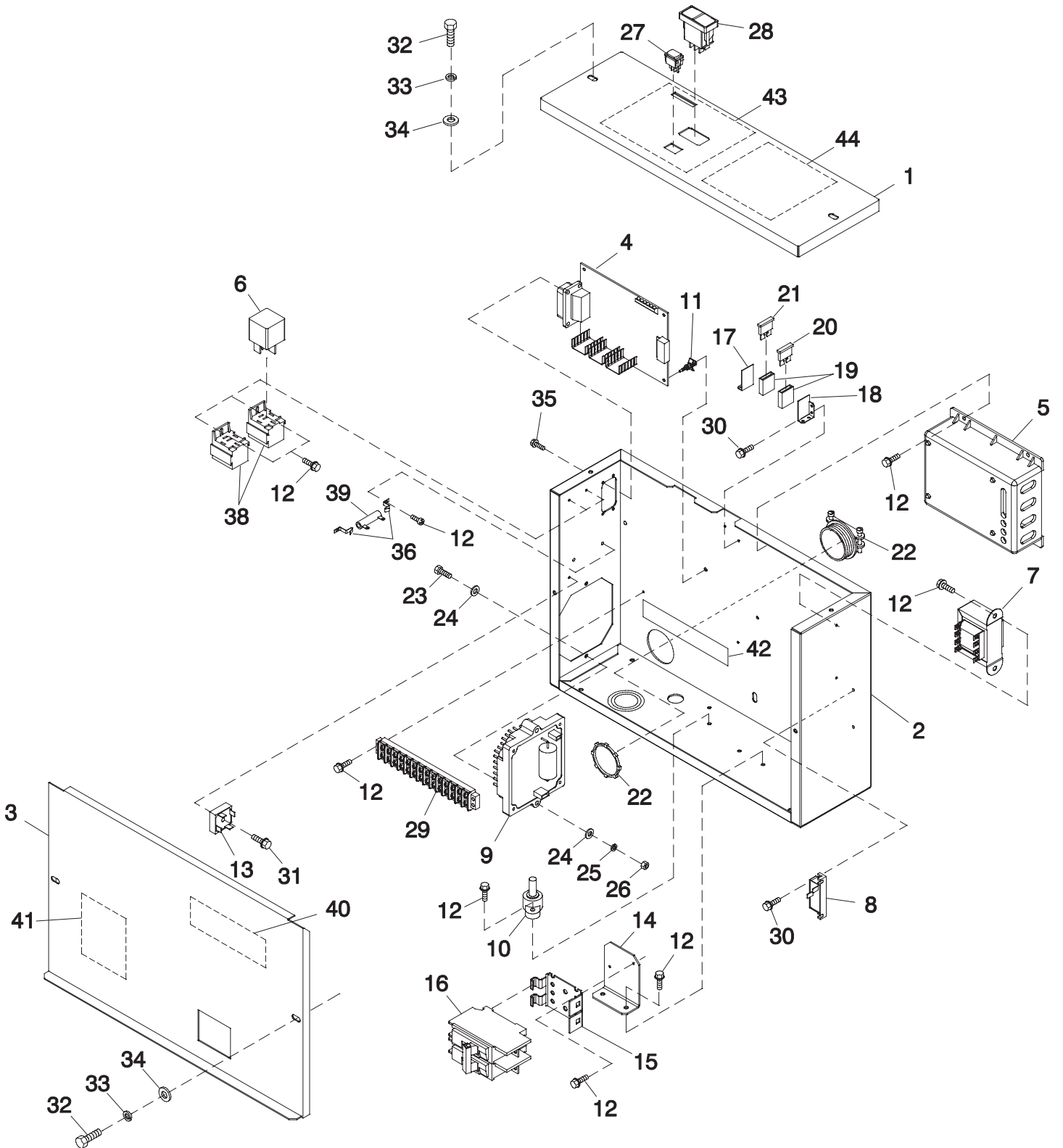

Section 7 - Exploded Views and Parts Lists

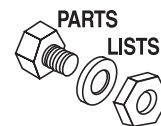

Liquid-cooled 25 kW Generators
Control Panel (15kW and 20kW) – Drawing No. 0F2267-D

ITEM	PART NO.	QTY.	DESCRIPTION
1	0F0790	1	TOP, CONTROL PANEL
2	0F0789	1	BACK & BOTTOM, CONTROL PANEL
3	0F0791	1	PANEL, FRONT 2.5L CONTROL PNL
4	0E9704	1	ASSY PCB HSB CONTROLLER 2.5L
5	067680	1	ASSY VOLTAGE REGULATOR 60HZ
6	0E6875A	2	RELAY, 12VDC C FORM W/DIODE
7	0C3910	1	XFMR 240/16V 1VA&56VA
8	048468	1	CIRCT BRK 8 X 1 ETA 46-500-P
9	0D5070A	1	ASSY PCB 2A 12V UL BATT CHRGR
10	057073	1	JUNCTION BLOCK 3/8-16
11	040213	2	PCB SUPPORT SNAP-IN 1/4"
12	0C2265	18	SCREW PHTT M4-0.7 X 12 ZYC
13	029673	1	DIO BRIDGE 25A 600V
14	0F0793	1	BRACKET, CB SIEMENS BQ
15	0E7890	1	BRKT CB MTG BACK
16	0D5541*	1	CB 0070A 2P 240V S BQ2 LL
	0D5544**	1	CB 0100A 2P 240V S BQ2 LL
17	0F1264	1	ADPTR,LH SIDE WICKMAN 178.6192
18	0F1263	1	ADPTR,RH SIDE WICKMAN 178.6191
19	0F1262	2	HOLDER, FUSE WICKMANN 178.6150
20	0E7403A	1	FUSE ATO TYPE 5 AMP (TAN)
21	0E7403C	1	FUSE, ATO TYPE 15 AMP (BLUE)
22	0E2514	1	FITTING CONDUIT STR 1-1/2"
23	020911	2	SCREW PPHM M5-0.8 X 30 ZINC
24	023897	4	WASHER FLAT #10 ZINC
25	022152	2	WASHER LOCK #10
26	051716	2	NUT HEX M5-0.8 G8 YEL CHR
27	082573	1	SWITCH ROC DPST 125V SPD
28	0E4494	1	SWITCH ROC DPDT ON-OFF-ON
29	0C4167	REF.	BLOCK TERM 20A 14 X 6 X 1100V
30	0C2699	4	SCREW PHTT #6-32 X 3/8 ZYC
31	0C2212	1	SCREW PHTT M4-0.7 X 16 ZYC
32	047411	4	SCREW HHC M6-1.0 X 16 G8.8
33	022097	4	WASHER LOCK M6-1/4
34	022473	4	WASHER FLAT 1/4-M6 ZINC
35	0E7358	4	SCREW PPPH HI-LO #4-24 X 3/8
36	064733	2	RES MTG BRACKET
37	0F0798A	1	HARNESS, C-PNL 2.5L QS 15&20KW (NOT SHOWN)
38	0E6881	REF	SOCKET, RELAY
39	048352	1	RES 5R 5% 25W
40	0C1127	1	DECAL AVR COVER
41	0C1229	1	DECAL WARNING ELECTRICAL SHOCK
42	0F2632	1	DECAL TERMINAL BLOCK
43	0F2629	1	DECAL CONTROL HSB
44	0E7193	1	DECAL, WARNINGS HSB
45	0F6146	1	HANG TAG 2 WIRE START (NOT SHOWN)

* 15KW

** 20KW



RTS
L

Section and Parts Lists

Liquid-
Control
Operators
Drawing No. OE7615-C

32

33

27

28

42



Section 7 - Exploded Views and Parts Lists
Liquid-cooled 25 kW Generators
Control Panel (25kW) – Drawing No. 0E7615-C



ITEM	PART NO.	QTY.	DESCRIPTION
1	0F0790	1	TOP, CONTROL PANEL
2	0F0789	1	BACK & BOTTOM, CONTROL PANEL
3	0F0791	1	PANEL, FRONT 2.5L CONTROL PNL
4	0E9704	1	ASSY PCB HSB CONTROLLER 2.5L
5	067680	1	ASSY VOLTAGE REGULATOR 60HZ
6	0E6875A	2	RELAY, 12VDC C FORM W/DIODE
7	0C3910	1	XFMR 240/16V 1VA&56VA
8	054450	1	CIRCT BRK 5.5 X 1 ETA 46-500-P
9	0D5070A	1	ASSY PCB 2A 12V UL BATT CHRGR
10	057073	1	JUNCTION BLOCK 3/8-16
11	040213	2	PCB SUPPORT SNAP-IN 1/4"
12	0C2265	16	SCREW PHTT M4-0.7 X 12 ZYC
13	029673	1	DIO BRIDGE 25A 600V
14	0F0793	1	BRACKET, CB SIEMENS BQ
15	0E7890	1	BRKT CB MTG BACK
16	0A2077	1	CB 0125A 2P 240V S BQ2 LL
17	0F1264	1	ADPTR,LH SIDE WICKMAN 178.6192
18	0F1263	1	ADPTR,RH SIDE WICKMAN 178.6191
19	0F1262	2	HOLDER, FUSE WICKMANN 178.6150
20	0E7403A	1	FUSE ATO TYPE 5 AMP (TAN)
21	0E7403C	1	FUSE, ATO TYPE 15 AMP (BLUE)
22	0E2514	1	FITTING CONDUIT STR 1-1/2"
23	020911	2	SCREW PPHM M5-0.8 X 30 ZINC
24	023897	4	WASHER FLAT #10 ZINC
25	022152	2	WASHER LOCK #10
26	051716	2	NUT HEX M5-0.8 G8 YEL CHR
27	082573	1	SWITCH ROC DPST 125V SPD
28	0E4494	1	SWITCH ROC DPDT ON-OFF-ON
29	0C4167	REF.	BLOCK TERM 20A 14 X 6 X 1100V
30	0C2699	4	SCREW PHTT #6-32 X 3/8 ZYC
31	0C2212	1	SCREW PHTT M4-0.7 X 16 ZYC
32	047411	4	SCREW HHC M6-1.0 X 16 G8.8
33	022097	4	WASHER LOCK M6-1/4
34	022473	4	WASHER FLAT 1/4-M6 ZINC
35	0E7358	4	SCREW PPPH HI-LO #4-24 X 3/8
37	0F0798	1	HARNESS CTRL PNL 2.5L FORD AL (NOT SHOWN)
38	0E6881	REF.	SOCKET, RELAY
39	0C1127	1	DECAL AVR COVER
40	0C1229	1	DECAL WARNING ELECTRICAL SHOCK
41	0F2632	1	DECAL TERMINAL BLOCK
42	0F2629	1	DECAL CONTROL HSB
43	0E7193	1	DECAL, WARNINGS HSB
44	0F6146	1	HANG TAG 2 WIRE START (NOT SHOWN)

Section 7 - Exploded Views and Parts Lists

Liquid-cooled 25 kW Generators

Engine – Drawing No. 0E9918-F

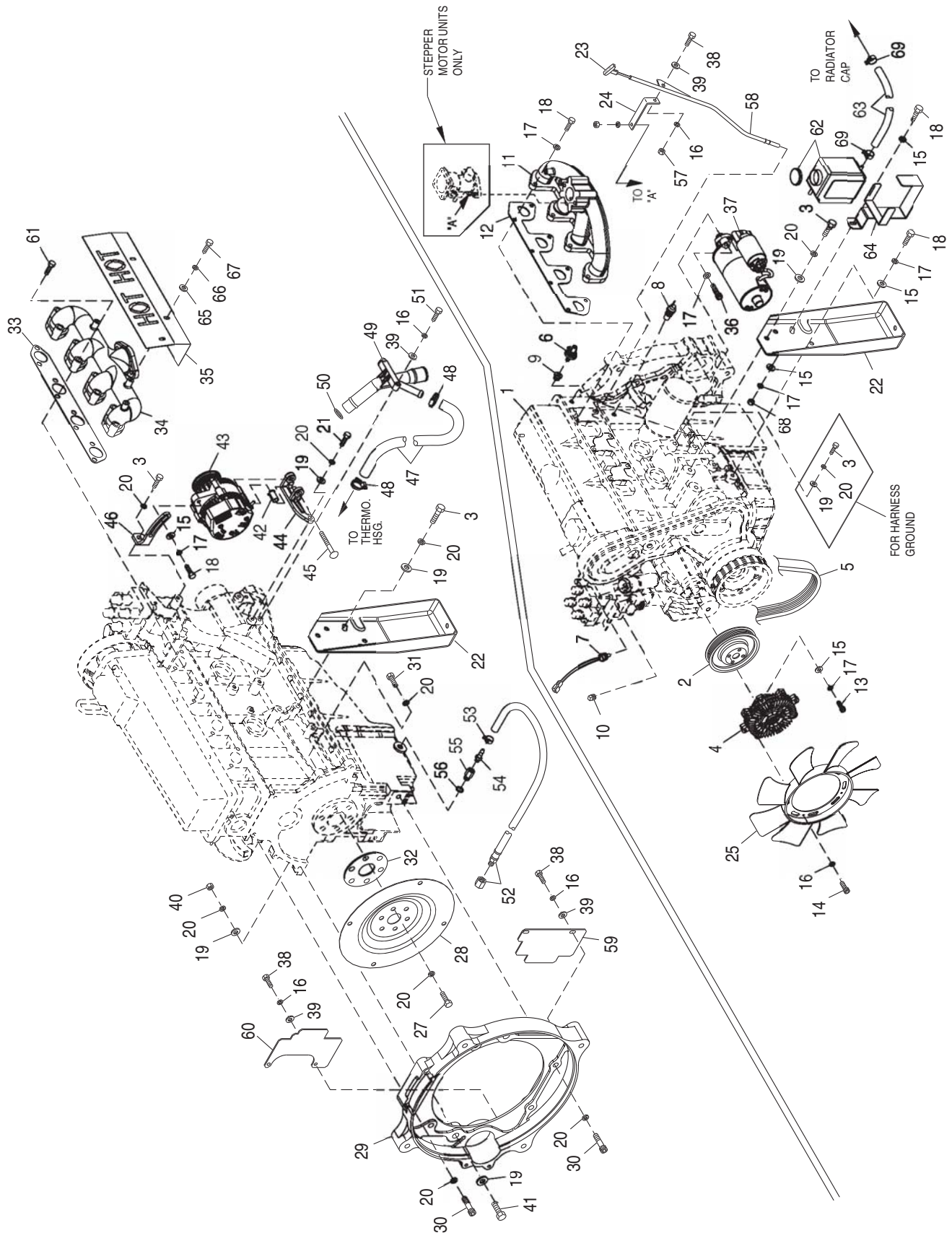

Section 7 - Exploded Views and Parts Lists

Liquid-cooled 25 kW Generators
Engine – Drawing No. 0E9918-F

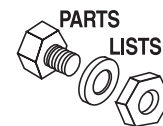

ITEM	PART NO.	QTY.	DESCRIPTION	ITEM	PART NO.	QTY.	DESCRIPTION
1	0E9909	REF	ENGINE 2.5L FORD	35	0E9930	1	HEAT SHIELD, EXHAUST MANIFOLD
2	0E9739	1	PULLEY, 2.5L FORD WATER PUMP	36	049821	3	SCREW SHC M8-1.25 X 30 G12.9
3	049814	8	SCREW HHC M10-1.5 X 25 G8.8	37	0E9747	1	STARTER, 12 VOLT
4	0F0001	1	CLUTCH, COOLING FAN 2.5L FORD	38	043116	5	SCREW HHC M6-1.0 X 12 G8.8
5	0D3488B	1	SERPENTINE BELT - 40.85" LENGTH	39	022473	6	WASHER FLAT 1/4-M6 ZINC
6	0A8584	1	SWITCH,OIL PRESSURE,10PSI,2POL	40	045772	2	NUT HEX M10-1.5 G8 YEL CHR
7	0E0561	1	ASSY WATER LEVEL SENSOR C/E PL	41	064416	2	SCREW HHC M10-1.5 X 45 G8.8
8	0A6751	1	SW-TMP 245DEG 3/8NPT	42	0F0252	1	SPRING BUSHING
9	035579	1	BUSHING REDUCER 1/4 TO 1/8	43	0E9868	1	ALTERNATOR, D.C
10	026925	1	PLUG STD PIPE 3/8 STEEL SQ HD	44	0F0035	1	BRKT,D.C. ALTERNATOR(MACHINED)
11	0E9611	1	MANIFOLD, INTAKE (MACHINED) (STEPPER MOTOR)	45	026082	1	SCREW HHC 3/8-16 X 2-1/4 G5
	0E9611A	1	MANIFOLD INTAKE MACH BOSCH32 (BOSCH GOV.) (NOT SHOWN)	46	0E9928	1	TENSIONER, D.C. ALTERNATOR
12	0E9681	1	GASKET, 2.5L FORD INTAKE MAN.	47	0F0383	1	HOSE,2.5L FORD COOLANT BY- PASS
13	039253	4	SCREW HHC M8-1.25 X 20 G8.8	48	057823	2	CLAMP HOSE #10 .56-1.06
14	097962	4	SCREW SHC M6-1.0 X 25 G12.9 ZP	49	0E9737	1	LOWER HOSE ADAPTER,2.5L FORD
15	022145	8	WASHER FLAT 5/16-M8 ZINC	50	0F0393	1	O-RING 1-3/16 X 1-7/16 X 1/8
16	022097	11	WASHER LOCK M6-1/4	51	045757	2	SCREW HHC M6-1.0 X 25 G8.8
17	022129	16	WASHER LOCK M8-5/16	52	069860C	1	HOSE OIL DRAIN ASSY 21"
18	043107	11	SCREW HHC M8-1.25 X 25 G8.8	53	048031J	REF	HOSE CLAMP BAND 5/8"
19	022131	19	WASHER FLAT 3/8-M10 ZINC	54	055596	1	BARBED STR 3/8NPT X 3/8
20	046526	22	WASHER LOCK M10	55	077456	1	ADAPTER M12-1.75 3/8NPT
21	052625	2	SCREW SHC M10-1.5 X 35 G12.9	56	052677	1	WASHER NYLON .50 X .87 X .06
22	0E9708	2	ENGINE FOOT, 2.5L FORD	57	049813	1	NUT HEX M6 X 1.0 G8 YEL CHR
23	0E9738	1	DIPSTICK, 2.5L FORD	58	0E9738A	1	DIPSTICK TUBE, 2.5L FORD
24	0E9929	1	BRACKET, DIPSTICK TUBE	59	0F1132	1	COVER, R/H SIDE ENGINE ADAPTOR
25	0F0230	1	FAN 16" COOLING	60	0F1133	1	COVER, L/H SIDE ENGINE ADAPTOR
26	0E9834	1	HARNESS, 2.5L FORD ENGINE (NOT SHOWN)	61*	059355	8	SCREW SHC M10-1.50 X 50 G12.9
	0E9834A	1	HARNESS,2.5L FORD (BOSCH GOV.) (NOT SHOWN)	62	076749	1	TANK COOLANT RECOVERY
27	0D5417	6	SCREW HHC M10-1.0 X 25 G10.9	63	029032	1	HOSE 9/32 ID (39"LG)
28	0E5048B	1	FLEXPLATE 2.5L FORD	64	0F1433	1	BRACKET,2.5L FORD WATER BOTTLE
29	0E9655	1	ADAPT CASTING MACH 2.5L FORD	65	070007	3	WASHER FLAT M6 SS
30	057192	4	SCREW SHC M10-1.5 X 30 G12.9	66	070005	3	WASHER LOCK M6 SS
31	060619	2	SCREW SHC M10-1.50 X 40 G12.9	67	080826	3	SCREW HHC M6-1.0 X 12 SS
32	0E8940	1	SPACER FLEXPLATE HSB	68	045771	1	NUT HEX M8-1.25 G8 YEL CHR
33	0E9680	1	GASKET, 2.5L FORD EXHAUST MAN.	69	048031C	2	CLAMP HOSE BAND 1/4
34	0E9609	1	MANIFOLD, EXHAUST (MACHINED)				

* NOTE: TORQUE TO 44 FT/LBS.

Section 7 - Exploded Views and Parts Lists

Liquid-cooled 25 kW Generators

Fuel System – Drawing No. 0E9980-D

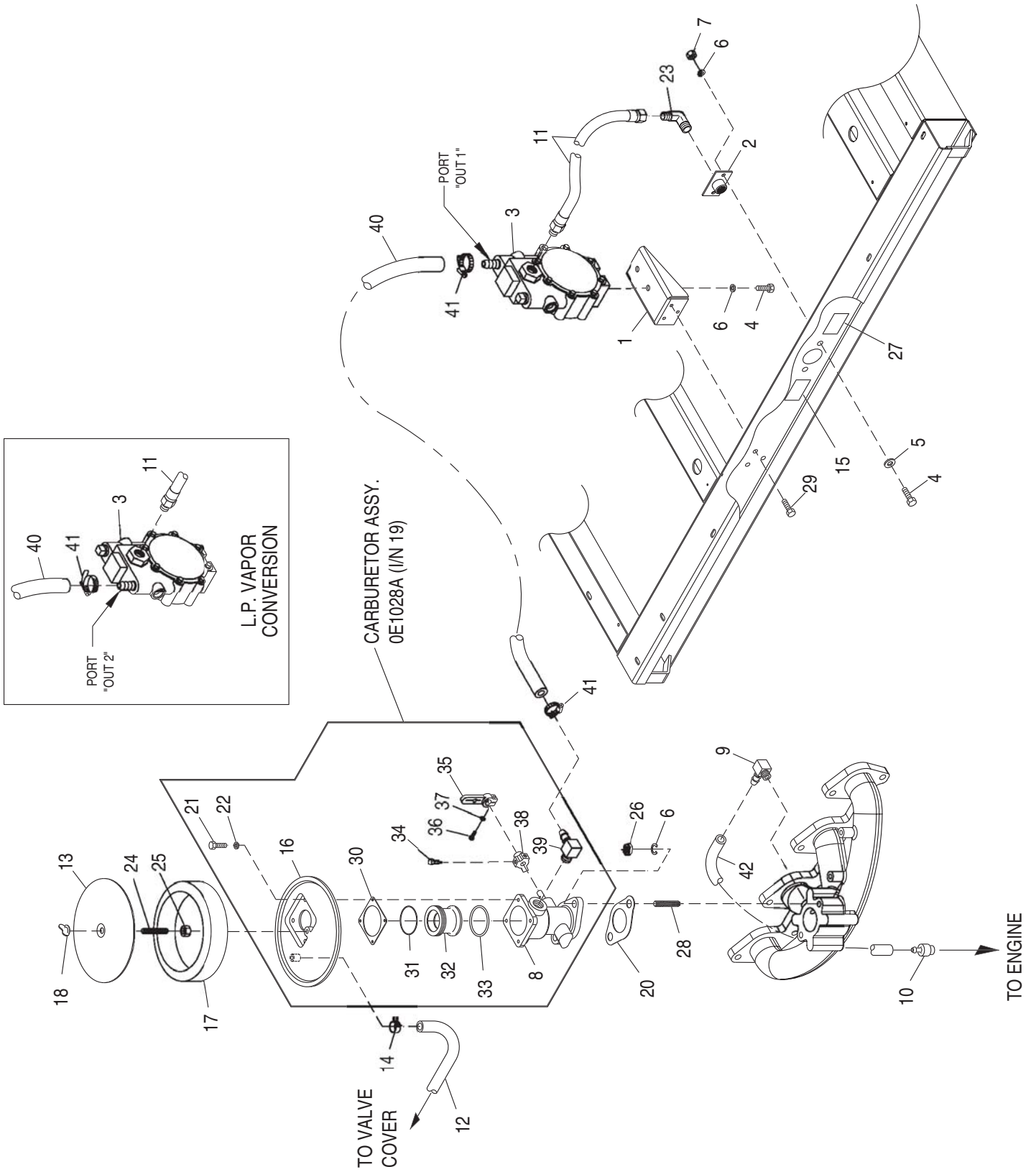

Section 7 - Exploded Views and Parts Lists

Liquid-cooled 25 kW Generators
Fuel System – Drawing No. 0E9980-D

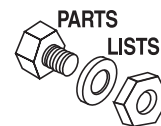

ITEM	PART NO.	QTY.	DESCRIPTION
1	0E8456	1	BRACKET FUEL REGULATOR
2	075580	1	FLANGE FUEL INLET
3	0E9967	1	ASSY FUEL REG 2.5L FRD N/G-L/P
4	039253	4	SCREW HHC M8-1.25 X 20 G8.8
5	022145	2	WASHER FLAT 5/16 ZINC
6	022129	6	WASHER LOCK M8-5/16
7	045771	2	NUT HEX M8-1.25 G8 YEL CHR
8 *	0F1570	1	BODY CARBURETOR ASSEMBLY
9	0A6344	1	BARBED EL 90 1/8 NPT X 3/8
10	0F3994	REF.	PCV VALVE 2.5L FORD
11	0E1056	1	FUEL HOSE ASSM. NAT. GAS/L.P.V.
12	0F0397	1	HOSE CRANKCASE BREATHER
13	0A5547	1	COVER AIR CLEANER
14	048031C	2	CLAMP HOSE BAND 1/4
15	0D1509	1	DECAL INLET PRESSURE
16 *	0E0591	1	ADAPTER CARB. TO AIR CLNR
17	059402	1	FILTER ELEMENT
18	037561	1	NUT WING 1/4-20 NYLK
19	0E1028A	1	CARBURETOR ASSY. 2.5L FORD
20	059401	1	CARBURETOR GASKET
21 *	091526	4	SCREW PPHM M5-0.8 X 12 ZNC
22 *	049226	4	WASHER LOCK M5
23	026307	1	ELBOW 90D STREET 3/4
24	062522	1	STUD TH 1/4-20 X 3 G2 ZNC FULL
25	022127	1	NUT HEX 1/4-20 STEEL
26	022259	2	NUT HEX 5/16-18 STEEL
27	050279	1	DECAL FUEL INLET NG
28	0A6125	2	STUD 5/16-18 X 1.25 F THR
29	0C2454	3	SCREW TH-FRM M6-1 X 16 N WA Z/JS
30*	0E1104	1	GASKET, AIR CLEANER ADAPTER
31*	0E0668	1	O-RING 2-028 1.38 X 1.50 X .06
32*	0E0590A	1	VENTURI 20MM
33*	0C5133	1	O-RING 29.82 X 2.62
34*	0E0665	1	SCREW THROTTLE PIN STOP
35*	0E1108	1	THROTTLE ARM REWORK
36*	033138	1	SCREW HHM #10-32 X 5/8
37*	022152	1	WASHER LOCK #10
38*	0E0645	1	LEVER, THROTTLE STOP
39*	034339	1	BARBED EL 90 3/8 NPT X 5/8
40	059194	1	HOSE 5/8 ID LPG & NG (24" LG)
41	057823	2	CLAMP HOSE #10 .56 - 1.06
42	0F0382	1	HOSE 3/8" 90 DEG 2.5L PVC

* INCLUDED IN ITEM 19 (CARBURETOR ASSY)

Section 7 - Exploded Views and Parts Lists

Liquid-cooled 25 kW Generators
Alternator – Drawing No. 0F5092-B

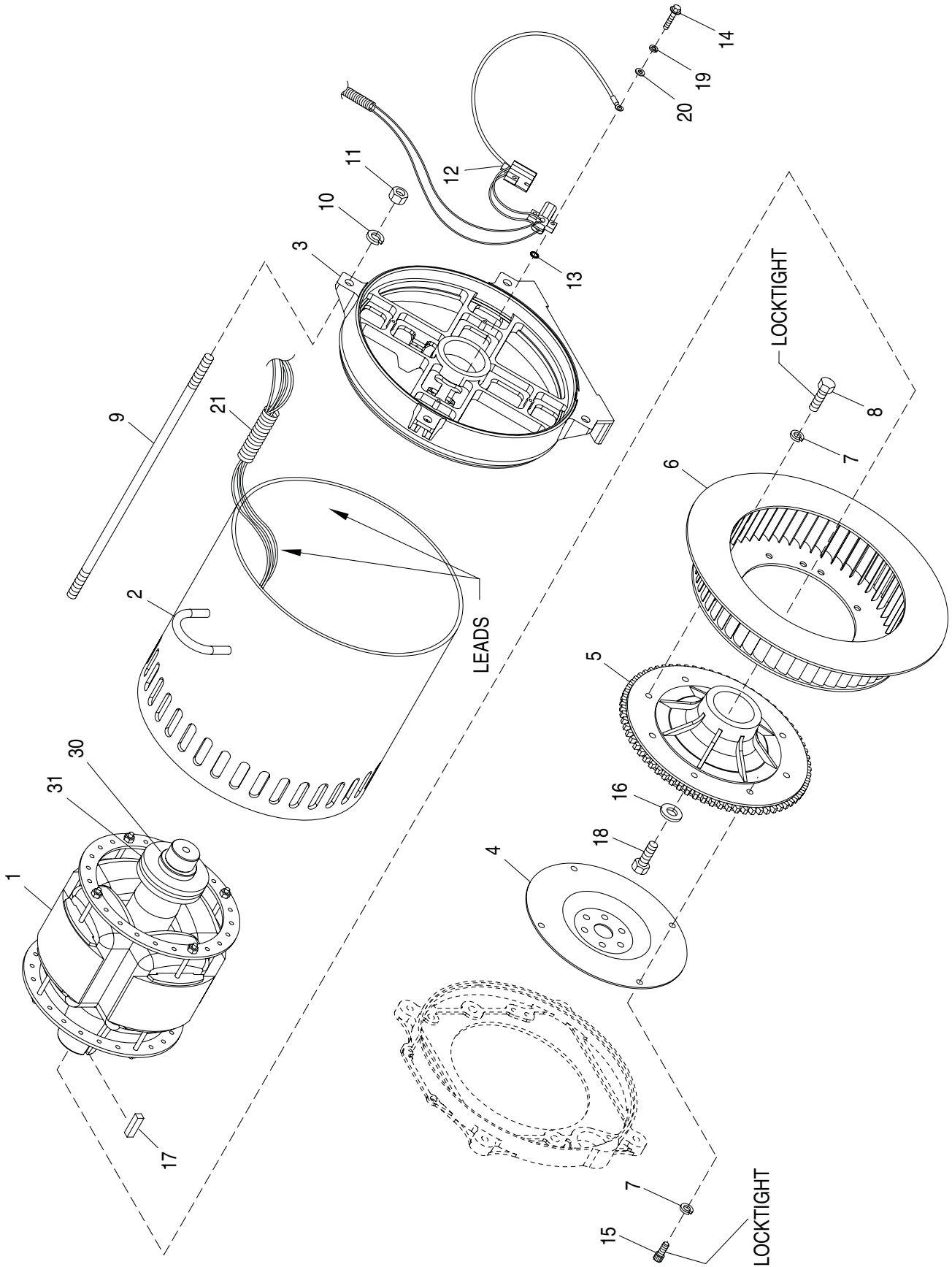

Section 7 - Exploded Views and Parts Lists

Liquid-cooled 25 kW Generators
Alternator – Drawing No. 0F5092-B

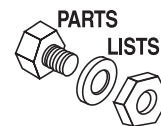

ITEM	PART NO.	QTY.	DESCRIPTION
1	0F1659A	1	ROTOR 390 15KW 1P DIRECT HSB (2.5L FORD)
	0F1657A	1	ROTOR 390 20KW 1P DIRECT HSB (2.5L FORD)
	0F1655A	1	ROTOR 390 25KW 1P DIRECT HSB (2.5L FORD)
	0F5073A	1	ROTOR 390__30AD1 HSB TECUM
	0E7413A	1	RTR 390 40KW 1P DIRECT HSB
2	0F1660A	1	STR 390 15AD HSB (382MM LONG) (2.5L FORD)
	0F1658A	1	STR 390 20AD HSB (382MM LONG) (2.5L FORD)
	0F1656A	1	STR 390 25AD HSB (382MM LONG) (2.5L FORD)
	0F5074A	1	STR-390__30AD1 HSB TECUM
	0E7412A	1	STR-390--40AD HSB (433MM LONG)
3	0E5706	1	REAR BEARING CARRIER 390/DRCT
4	0E5048	REF	FLEXPLATE 3.0L FORD
	0E5048B	REF	FLEXPLATE 2.5L FORD
	0E5048A	REF	FLEXPLATE HSB 3.9L CHRYSLER
5	0E6668	1	FLYWHEEL ASSY 3.0L HSB LG GEAR
6	0E6076	1	REVCOR FAN 10.75 X 2 W/PRESS DIS
7	046526	8	WASHER LOCK M10
8	051755	4	SCREW HHC M10-1.5 X 16 G8.8
9	04576100BK	4	STUD M14-2.0 X 490 G5 ZINC (3.0L FORD & 2.5L FORD)
	04576100BF	4	STUD M14-2.0 X 540 G5 ZINC
10	043123	4	WASHER LOCK M14
11	051779	4	NUT HEX M14-2.0 G8 YEL CHR
12	0E7587	1	ASSY BRUSH HOLDER 390/HSB
13	023365	1	WASHER SHAKEPROOF INT #8
14	092980	4	SCREW PPHM M4-0.7 X 25
15	057192	4	SCREW SHC M10-1.5 X 30 G12.9
16	0A2602	1	WASHER FLAT .688 ID X 3.25 OD
17	042558	1	KEY SQ 3/8 X 1 STEEL
18	0A2601	1	SCREW HHC M16-2.0 X 45 G8.8
19	022264	4	WASHER LOCK #8-M4
20	038150	4	WASHER FLAT #8 ZINC
21	077043F	1	CONDUIT FLEX 1-1/4" (30" LG - 3.0L FORD & 3.9L CHRYSLER)
	077043F	1	CONDUIT FLEX 1-1/4" (18" LG – 2.5L FORD)
ROTOR REPLACEMENT PARTS			
30	047248	1	BALL BEARING-45 MM
31	070892	1	SLIP RING -MACHINED-

Section 7 - Exploded Views and Parts Lists

**Liquid-cooled 25 kW Generators
Muffler – Drawing No. 0F2930-C**

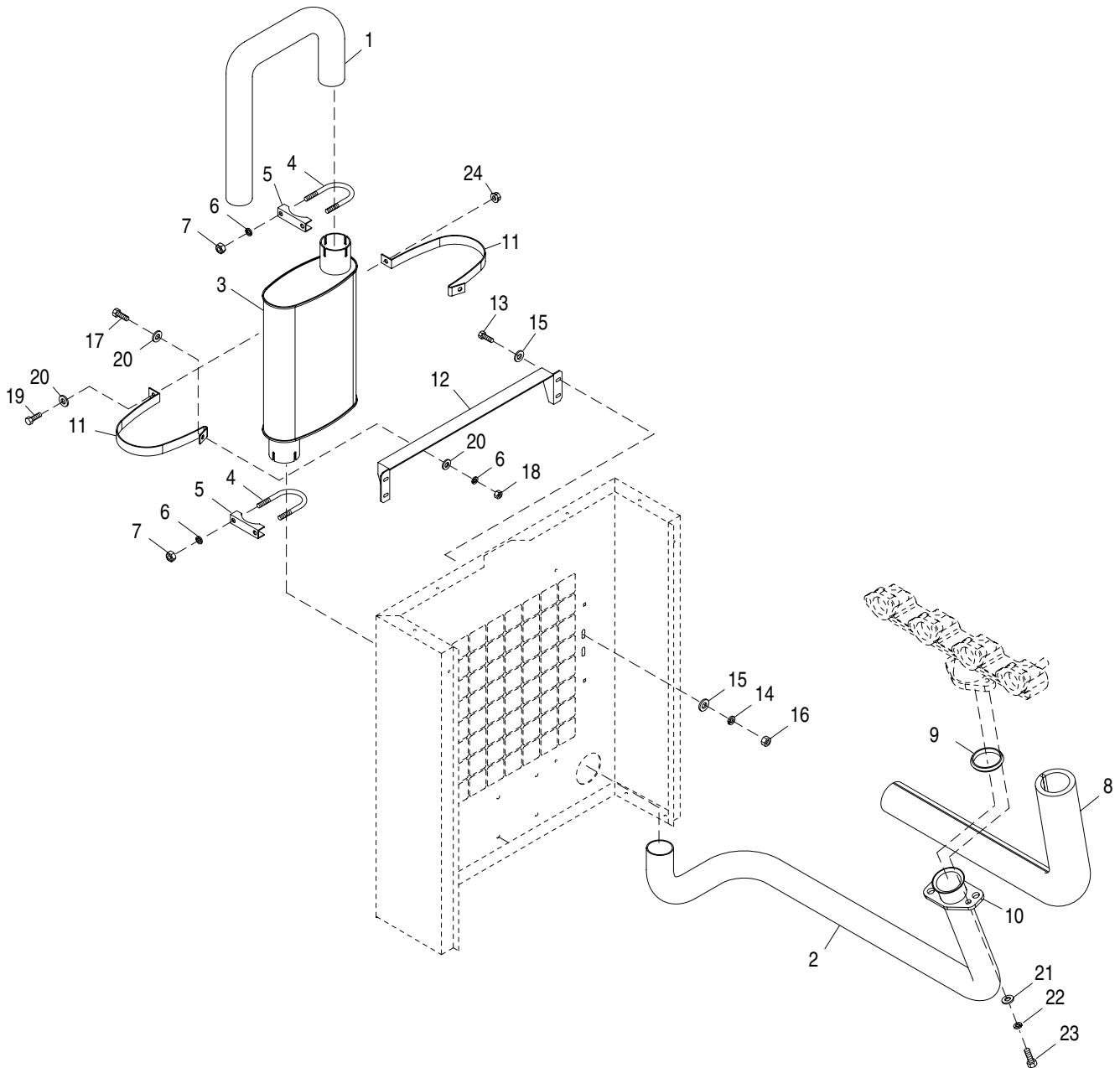

ITEM	PART NO.	QTY.	DESCRIPTION	ITEM	PART NO.	QTY.	DESCRIPTION
1	0F2912	1	PIPE MUFFLER OUT	13	042568	4	SCREW HHC M6-1.0 X 20 G8.8
2	0F2869	1	PIPE EXHAUST 2.5L FORD	14	022097	4	WASHER LOCK M6-1/4
3	0F2823	1	MUFFLER 2.5L FORD	15	022473	8	WASHER FLAT 1/4-M6 ZINC
4	036434	2	BOLT U 5/16-18 X 2.09	16	049813	4	NUT HEX M6 X 1.0 G8 YEL CHR
5	036449	2	SADDLE 2 INCH	17	039253	2	SCREW HHC M8-1.25 X 20 G8.8
6	022129	6	WASHER LOCK M8-5/16	18	045771	2	NUT HEX M8-1.25 G8 YEL CHR
7	022259	4	NUT HEX 5/16-18 STEEL	19	0A4010	1	SCREW HHC M8-1.25 X 60 G8.8 FT
8	0E0170A	1	EXHAUST BLANKET 800MM	20	022145	5	WASHER FLAT 5/16-M8 ZINC
9	044149	1	GASKET EXHAUST RING	21	022131	2	WASHER FLAT 3/8-M10 ZINC
10	0E8816	1	EXHAUST FLANGE 2" PIPE	22	085917	2	WASHER LOCK 3/8 SS
11	0F2925	2	STRAP MUFFLER	23	0D2611	2	SCREW HHC 3/8-16 X 1-3/4 SS
12	0F2926	1	BRACKET, MUFFLER	24	052858	1	NUT TOP LOCK FL M8-1.25

Section 7 - Exploded Views and Parts Lists

Liquid-cooled 25 kW Generators
Stepper Motor – Drawing No. 0E9979-C

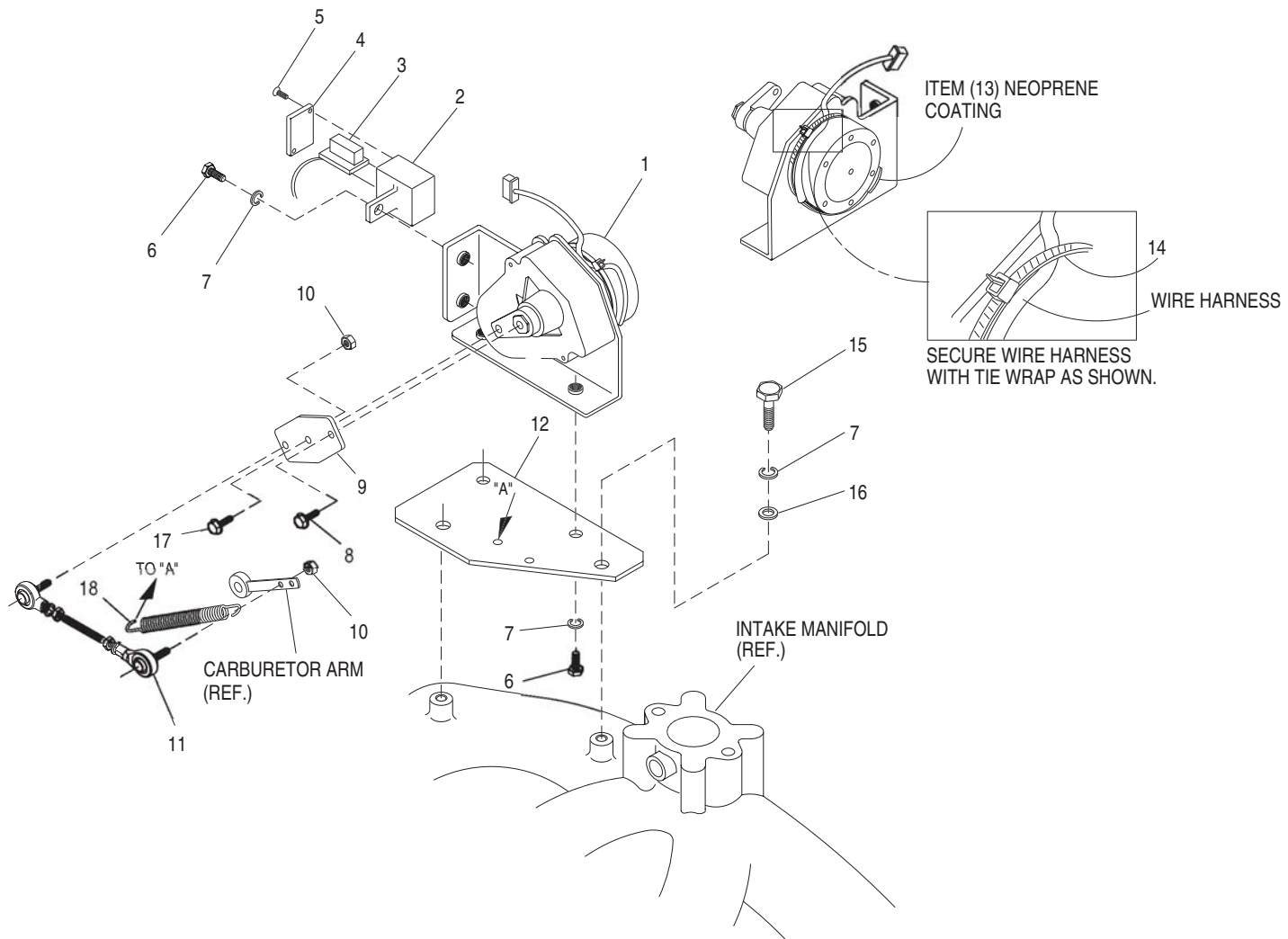
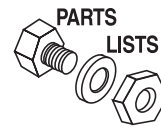

ITEM	PART NO.	QTY.	DESCRIPTION
1	098290	1	ASM MOTOR STEPPER
2	098941A	1	HOUSING GOVERNOR CONNECTOR
3	0F0454	REF	HARN GOV 2.5L FORD
4	098942A	1	COVER CONNECTOR HOUSING
5	098225	2	SCREW PFHST #2 X 5/8
6	043146	3	SCREW HHC M6-1.0 X 10 G8.8
7	022097	5	WASHER LOCK M6-1/4
8	0E7358	REF	SCREW PPPH HI-LO #4-24 X 3/8
9	098783	1	LEVER STEPPER MOTOR
10	037398	2	NUT LOCK HEX #10-32 NYL INS
11	0E1326	1	ASSY. CARBURETOR LINKAGE ROD
12	0A7106	1	BRACKET STEPPER MOTOR
13	074031	AR	LIQUID NEOPRENE
14	029333A	1	TIE WRAP 7.4"X.19" BLK UL
15	022507	2	SCREW HHC 1/4-20 X 1/2 G5
16	022473	2	WASHER FLAT 1/4 ZINC
17	064526	1	SCREW TAP HWH #6-25 X 3/8 ZINC
18	0E1694	1	SPRING,ANTI LASH

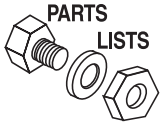

Section 7 - Exploded Views and Parts Lists

**Liquid-cooled 25 kW Generators
Radiator – Drawing No. 0E9965-F**

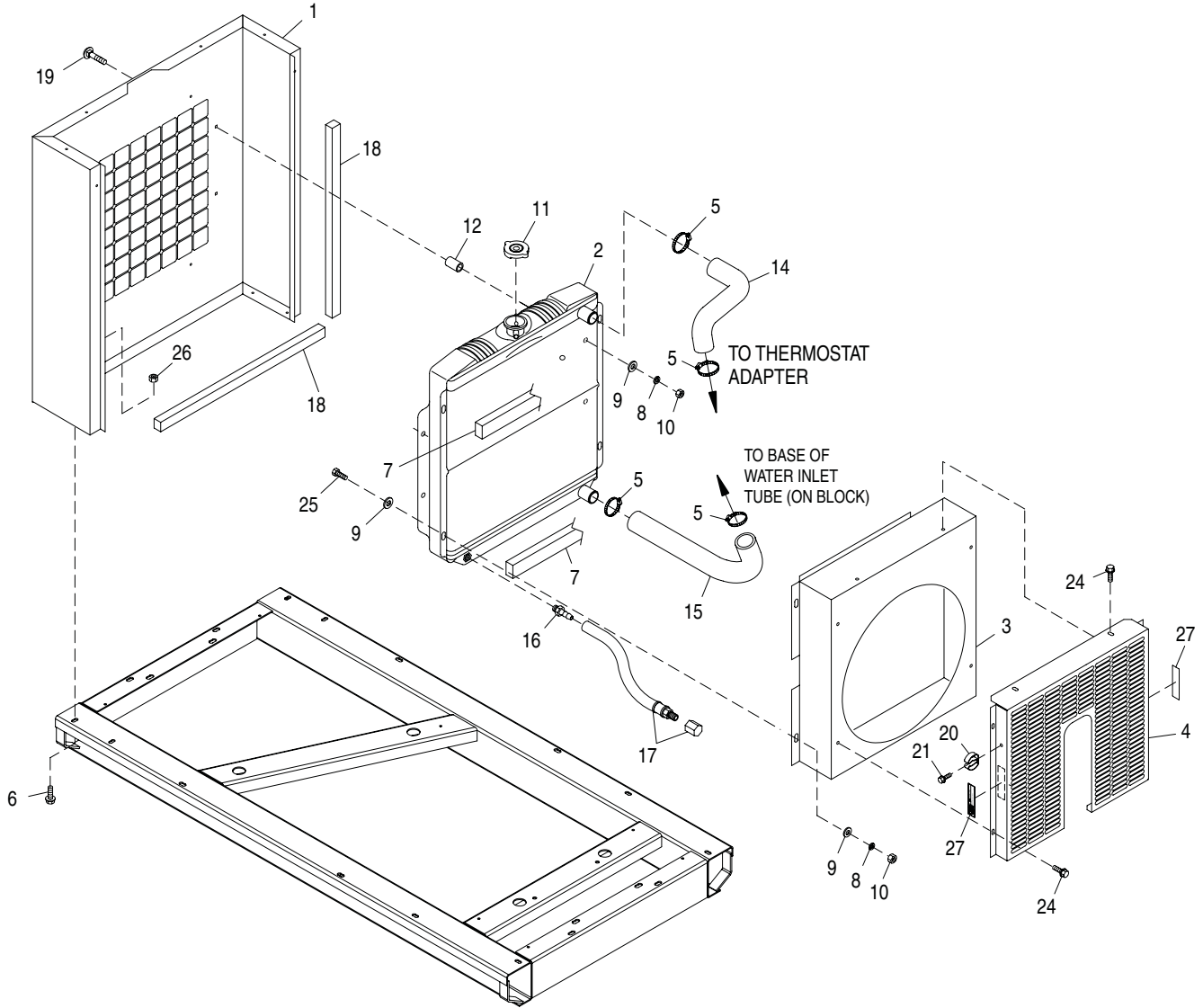

ITEM	PART NO.	QTY.	DESCRIPTION	ITEM	PART NO.	QTY.	DESCRIPTION
1	0E9769	REF	SUPPORT RADIATOR 2.5L FORD	15	0E9833	1	HOSE, 2.5L FORD LOWER
	0F0779	REF	SUPPORT RADIATOR 2.5L AL				RADIATOR
	0E9769A	REF	SUPPORT RADIATOR 2.5L FORD	16	035461	1	BARBED STR 1/4 NPT X 3/8
			ALM	17	069860C	1	HOSE OIL DRAIN ASSY 21"
2	0E9837	1	RADIATOR 2.5L FORD	18	0A7275	4	FOAM 1.5 X 1 ADHESIVE BACKING
3	0F0123	1	VENTURI 16" FAN 2.5L FORD				(21.5" LG)
4	0F0118	1	GUARD FAN 2.5L FORD	19	031669	4	BOLT CARR 1/4-20 X 1-3/4 JS500
5	099502	4	CLAMP HOSE #24 B1.06-2.00	20	065852	1	SPRING CLIP HOLDER .37-.62
6	0C2454	REF.	SCREW THF M6-1 X 16 N WA Z/JS	21	0A2111	1	SCREW SWAGE 10-32 X 5/16 Z/YC
7	052250	2	TAPE FOAM 1 X 1(21" LG)	24	0C2454	6	SCREW TH-FRM M6-1 X 16 N WA
8	022097	8	WASHER LOCK M6-1/4				Z/JS
9	022473	12	WASHER FLAT 1/4 ZINC	25	022287	4	SCREW HHC 1/4-20 X 3/4 G5
10	022127	8	NUT HEX 1/4-20 STEEL	26	077992	REF	NUT HEX LOCK M6-1.0 SS NY INS
11	046627	1	CAP RADIATOR	27	050275	2	DECAL WARNING-FAN
12	060035	4	SPACER .41 X .75 X .87 ST/ZNC				
14	0F0127	1	HOSE, UPPER RADIATOR 174MM				TAL