

# RTS Automatic Transfer Switch

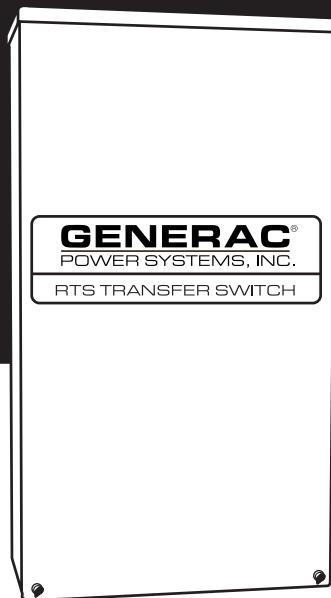

## TECHNICAL MANUAL







*A new standard of reliability*

**GENERAC®**  
POWER SYSTEMS, INC.



 **SAVE THESE INSTRUCTIONS** - This manual contains important instructions that should be followed during installation and maintenance of the generator and batteries. 

 **SAVE THESE INSTRUCTIONS!** Read the following information carefully before attempting to install, operate or service this equipment. Also read the instructions and information on tags, decals, and labels that may be affixed to the transfer switch. Replace any decal or label that is no longer legible. 

 **DANGER!** Connection of a generator to an electrical system normally supplied by an electric utility shall be by means of suitable transfer equipment so as to isolate the electric system from utility distribution system when the generator is operating (Article 701 Legally Required Standby Systems or Article 702 Optional Standby Systems, as applicable). Failure to isolate electric system by these means may result in damage to generator and may result in injury or death to utility workers due to backfeed of electrical energy. 

Generac Power Systems, Inc., hereafter referred to as the “manufacturer”, cannot anticipate every possible circumstance that might involve a hazard. The warnings in this manual, and on tags and decals affixed to the unit are, therefore, not all-inclusive. If using a procedure, work method or operating technique the manufacturer does not specifically recommend, ensure that it is safe for others. Also make sure the procedure, work method or operating technique chosen does not render the transfer switch unsafe.

Throughout this publication, and on tags and decals affixed to the generator, DANGER, WARNING, CAUTION and NOTE blocks are used to alert personnel to special instructions about a particular operation that may be hazardous if performed incorrectly or carelessly. Observe them carefully. Their definitions are as follows:

### **DANGER**

After this heading, read instructions that, if not strictly complied with, will result in personal injury, including without limitation, death, or property damage.

### **WARNING**

After this heading, read instructions that, if not strictly complied with, may result in personal injury or property damage.

### **CAUTION**

After this heading, read instructions that, if not strictly complied with, could result in damage to equipment and/or property.

#### **NOTE:**

After this heading, read explanatory statements that require special emphasis.

These safety warnings cannot eliminate the hazards that they indicate. Common sense and strict compliance with the special instructions while performing the service are essential to preventing accidents.

Four commonly used safety symbols accompany the DANGER, WARNING and CAUTION blocks. The type of information each indicates follows:

 This symbol points out important safety information that, if not followed, could endanger personal safety and/or property.

 This symbol points out potential explosion hazard.

 This symbol points out potential fire hazard.

 This symbol points out potential electrical shock hazard.

### **GENERAL HAZARDS**

- Any AC generator that is used for backup power if a NORMAL (UTILITY) power source failure occurs, must be isolated from the NORMAL (UTILITY) power source by means of an approved transfer switch. Failure to properly isolate the NORMAL and STANDBY power sources from each other may result in injury or death to electric utility workers, due to backfeed of electrical energy.
- Improper or unauthorized installation, operation, service or repair of the equipment is extremely dangerous and may result in death, serious personal injury, or damage to equipment and/or personal property.
- Extremely high and dangerous power voltages are present inside an installed transfer switch. Any contact with high voltage terminals, contacts or wires will result in extremely hazardous, and possibly LETHAL, electric shock. **DO NOT WORK ON THE TRANSFER SWITCH UNTIL ALL POWER VOLTAGE SUPPLIES TO THE SWITCH HAVE BEEN POSITIVELY TURNED OFF.**

- Competent, qualified personnel should install, operate and service this equipment. Adhere strictly to local, state and national electrical and building codes. When using this equipment, comply with regulations the National Electrical Code (NEC), CSA Standard; C22.1 Canadian Electric Code and Occupational Safety and Health Administration (OSHA) have established.
- Never handle any kind of electrical device while standing in water, while barefoot, or while hands or feet are wet. **DANGEROUS ELECTRICAL SHOCK MAY RESULT.**
- Jewelry conducts electricity and wearing it may cause dangerous electrical shock. Remove all jewelry (such as rings, watches, bracelets, etc.) before working on this equipment.
- If work must be done on this equipment while standing on metal or concrete, place insulative mats over a dry wood platform. Work on this equipment only while standing on such insulative mats.
- Never work on this equipment while physically or mentally fatigued.
- Keep the transfer switch enclosure door closed and bolted at all times. Only qualified personnel should be permitted access to the switch interior.
- In case of an accident caused by electric shock, immediately shut down the source of electrical power. If this is not possible, attempt to free the victim from the live conductor but **AVOID DIRECT CONTACT WITH THE VICTIM.** Use a nonconducting implement, such as a dry rope or board, to free the victim from the live conductor. If the victim is unconscious, apply first aid and get immediate medical help.
- When an automatic transfer switch is installed for a standby generator set, the generator engine may crank and start at any time without warning. To avoid possible injury that might be caused by such sudden start-ups, the system's automatic start circuit must be disabled before working on or around the generator or transfer switch. For that purpose, a **SAFETY DISCONNECT** is provided inside the transfer switch. Always set that switch to its **OFF** position before working on the equipment. Then place a "DO NOT OPERATE" tag on the transfer switch and on the generator. Remove the Negative (Neg) or (-) battery cable.

**Safety Rules .....Inside Front Cover**

**Section 1 – General Information .....2**

1.1 Introduction..... 2

1.2 Equipment Description ..... 2

    1.2.1 Transfer Switch Mechanism..... 2

    1.2.2 Utility Service & Generator  
        Disconnect Circuit Breakers..... 2

1.3 Transfer Switch Data Decal..... 2

1.4 Transfer Switch Enclosure ..... 3

1.5 Safe Use Of Transfer Switch..... 3

**Section 2 – Installation .....3**

2.1 Introduction to Installation..... 3

2.2 Unpacking ..... 3

2.3 Mounting ..... 3

2.4 Connecting Power Source and Load Lines..... 3

2.5 Connecting Start Circuit Wires ..... 4

**Section 3 – Operation.....4**

3.1 Functional Tests & Adjustments ..... 4

3.2 Manual Operation..... 4

    3.2.1 Close to Utility Source Side..... 5

    3.2.2 Close to Generator Source Side ..... 5

    3.2.3 Return to Utility Source Side ..... 5

3.3 Voltage Checks..... 6

3.4 Generator Tests Under Load ..... 6

**Section 4 – Installation Diagram .....7**

**Section 5 – Electrical Data .....8**

**Section 6 – Exploded Views & Parts Lists .....12**

**Section 7 – Notes .....16**

**Section 8 – Warranty ..... Back Cover**

|  |
|--|
| <p><b>For authorized service,<br/>reference the dealer locator<br/>number found in the generator<br/>owner's manual.</b></p> |
|--|

## 1.1 INTRODUCTION

This manual has been prepared especially for the purpose of familiarizing personnel with the design, application, installation, operation and servicing of the applicable equipment. Read the manual carefully and comply with all instructions. This will help to prevent accidents or damage to equipment that might otherwise be caused by carelessness, incorrect application, or improper procedures.

Every effort has been expended to make sure that the contents of this manual are both accurate and current. The manufacturer, however, reserves the right to change, alter or otherwise improve the product at any time without prior notice.

## 1.2 EQUIPMENT DESCRIPTION

The automatic transfer switch is used for transferring electrical load from a UTILITY (NORMAL) power source to an GENERATOR (STANDBY) power source. Such a transfer of electrical loads occurs automatically when the UTILITY power source has failed or is substantially reduced and the GENERATOR source voltage and frequency have reached an acceptable level. The transfer switch prevents electrical feedback between two different power sources (such as the UTILITY and GENERATOR sources) and, for that reason, codes require it in all standby electric system installations.

The transfer switch consists of a transfer mechanism, UTILITY SERVICE DISCONNECT circuit breaker, GENERATOR DISCONNECT circuit breaker, a relay control, fuses, and a terminal strip for connection of sensing wires.

This transfer switch is suitable for use as service entrance equipment.

### ◆ 1.2.1 TRANSFER SWITCH MECHANISM

These switches (Figure 1.1) are used with a single-phase system, when the single-phase NEUTRAL line is to be connected to a Neutral Lug and is not to be switched.

Solderless, screw-type terminal lugs are standard.

| Switch Rating | Wire Range  | Conductor Tightening Torque |
|---------------|-------------|-----------------------------|
| 100A          | #14-1/0 AWG | 50 in-lbs.                  |
| 200A          | #6-250 MCM  | 275 in-lbs.                 |

This transfer switch is suitable for control of motors, electric discharge lamps, tungsten filament and electric heating equipment where the sum of motor full load ampere ratings and the ampere ratings of other loads do not exceed the ampere rating of the switch and the tungsten load does not exceed 30 percent of the switch rating.

**Figure 1.1 — Typical ATS Transfer Mechanism**

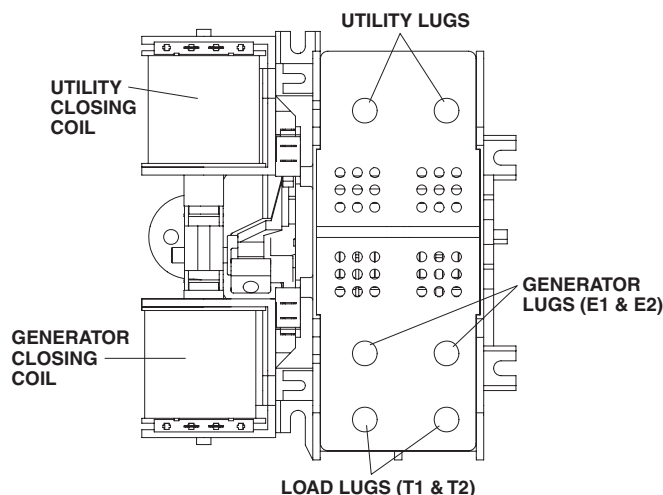

This transfer switch is for use in optional standby systems only.

This transfer switch is suitable for use on a circuit capable of 10,000 rms symmetrical amperes, 240 VAC maximum.

### ◆ 1.2.2 UTILITY SERVICE & GENERATOR DISCONNECT CIRCUIT BREAKERS

The utility service and generator disconnect circuit breakers for the 100 amp models are:

- Siemens, Type BQ, 2-pole
- 120/240VAC, 100A
- 50/60 Hertz
- Heating, Air Conditioning and Refrigeration (HACR) rated
- Wire range: #1 - #8 AWG.
- The conductor tightening torque is 50 in-lbs.

The utility service and generator disconnect circuit breaker for the 200 amp models are:

- Siemens, Type QN, 2-pole
- 120/240VAC, 200A
- 50/60 Hertz
- Heating, Air Conditioning and Refrigeration (HACR) rated
- Wire range: 300 KCMIL - 4 AWG
- The conductor tightening torque is 250 in-lbs.

## 1.3 TRANSFER SWITCH DATA DECAL

A DATA DECAL is permanently affixed to the transfer switch enclosure. Use this transfer switch only with the specific limits shown on the DATA DECAL and on other decals and labels that may be affixed to the switch. This will prevent damage to equipment and property.

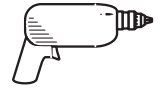

When requesting information or ordering parts for this equipment, make sure to include all information from the DATA DECAL.

Record the Model and Serial numbers in the space provided below for future reference.

|          |
|----------|
| MODEL #  |
| SERIAL # |
|          |

## 1.4 TRANSFER SWITCH ENCLOSURE

The standard switch enclosure is a National Electrical Manufacturer’s Association (NEMA) 3R type. NEMA 3R type enclosures primarily provide a degree of protection against falling rain and sleet and is undamaged by the formation of ice on the enclosure.

## 1.5 SAFE USE OF TRANSFER SWITCH

Before installing, operating or servicing this equipment, read the SAFETY RULES (inside front cover) carefully. Comply strictly with all SAFETY RULES to prevent accidents and/or damage to the equipment. The manufacturer recommends that a copy of the SAFETY RULES are posted near the transfer switch. Also, be sure to read all instructions and information found on tags, labels and decals affixed to the equipment.

Two publications that outline the safe use of transfer switches are the following:

- NFPA 70; National Electrical Code
- NFPA 70E; Standard for Electrical Safety in the Workplace
- UL 1008, STANDARD FOR SAFETY-AUTOMATIC TRANSFER SWITCHES

**NOTE:**

**It is essential to use the latest version of any standard to ensure correct and current information.**

## 2.1 INTRODUCTION TO INSTALLATION

This equipment has been wired and tested at the factory. Installing the switch includes the following procedures:

- Mounting the enclosure.
- Connecting power source and load leads.
- Connecting the generator sensing and transfer relay circuits.
- Connecting any auxiliary contact (if needed)
- Testing functions.

## 2.2 UNPACKING

Carefully unpack the transfer switch. Inspect closely for any damage that might have occurred during shipment. The purchaser must file with the carrier any claims for loss or damage incurred while in transit.

Check that all packing material is completely removed from the switch prior to installation.

## 2.3 MOUNTING

Mounting dimensions for the transfer switch enclosure are in this manual. Enclosures are typically wall-mounted. See “Installation Diagram”, Section 4.



**Handle transfer switches carefully when installing. Do not drop the switch. Protect the switch against impact at all times, and against construction grit and metal chips. Never install a transfer switch that has been damaged.**

This transfer switch is mounted in a NEMA 3R enclosure. It can be mounted outside or inside and should be based on the layout of installation, convenience and proximity to the utility supply and load center.

Install the transfer switch as close as possible to the electrical loads that are to be connected to it. Mount the switch vertically to a rigid supporting structure. To prevent switch distortion, level all mounting points. If necessary, use washers behind mounting holes to level the unit.

## 2.4 CONNECTING POWER SOURCE AND LOAD LINES



**Make sure to turn OFF both the UTILITY (NORMAL) and GENERATOR (STANDBY) power supplies before trying to connect power source and load lines to the transfer switch. Supply voltages are extremely high and dangerous. Contact with such high voltage power supply lines causes extremely hazardous, possibly lethal, electrical shock.**

Wiring diagrams and electrical schematics are provided in this manual.

Two suggested installation methods are shown. One for new installations and/or retrofit and one for retrofit.

**NOTE:**

**All installations must comply with national, state and local codes. It is the responsibility of the installer to perform an installation that will pass the final electrical inspection.**

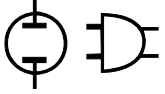

The utility supply connection is made at the UTILITY SERVICE DISCONNECT circuit breaker terminals. The generator supply connection is made at the GENERATOR DISCONNECT circuit breaker terminals. The customer load connections are made at the transfer switch mechanism, inside the switch enclosure.

Conductor sizes must be adequate to handle the maximum current to which they will be subjected, based on the 75°C column of tables, charts, etc. used to size conductors. The installation must comply fully with all applicable codes, standards and regulations.

Before connecting wiring cables to terminals, remove any surface oxides from the cable ends with a wire brush. All power cables must enter the enclosure through the knockouts. If not using the knockouts, entry must be at or below knockouts. If ALUMINUM conductors are used, apply corrosion inhibitor to conductors. Tighten terminal lugs to the torque values as noted in Section 1.2.2, and on the decal located on the inside of the door. After tightening terminal lugs, carefully wipe away any excess corrosion inhibitor.



⚠ Use a torque wrench to tighten the conductors, being sure not to overtighten, or damage to the switch base could occur. If not tightened enough, a loose connection would result, causing excess heat which could damage the switch base.

Connect power source load conductors to clearly marked transfer mechanism terminal lugs as follows

1. Connect UTILITY (NORMAL) power source cables to UTILITY SERVICE DISCONNECT circuit breaker.
2. Connect GENERATOR (STANDBY) source power cables to GENERATOR DISCONNECT circuit breakers.
3. Connect customer LOAD leads to switch terminals T1, T2.

Conductors must be properly supported, of approved insulative qualities, protected by approved conduit, and of the correct wire gauge size in accordance with applicable codes.

Be sure to maintain proper electrical clearance between live metal parts and grounded metal. Allow at least 1/2 inch for 100-400 amp circuits.

## 2.5 CONNECTING START CIRCUIT WIRES

Control system interconnections consist of N1 and N2, and leads 23 and 194. Control system interconnection leads must be run in a conduit that is separate from the AC power lead. Recommended wire gauge sizes for this wiring depends on the length of the wire, as recommended in the following chart:

| MAXIMUM WIRE LENGTH        | RECOMMENDED WIRE SIZE |
|----------------------------|-----------------------|
| 460 feet (140m)            | No. 18 AWG.           |
| 461 to 730 feet (223m)     | No. 16 AWG.           |
| 731 to 1,160 feet (354m)   | No. 14 AWG.           |
| 1,161 to 1,850 feet (565m) | No. 12 AWG.           |

## 3.1 FUNCTIONAL TESTS AND ADJUSTMENTS

**Following transfer switch installation and interconnection, inspect the entire installation carefully. A competent, qualified electrician should inspect it. The installation should comply strictly with all applicable codes, standards, and regulations. When absolutely certain the installation is proper and correct, complete a functional test of the system.**



⚠ Perform functional tests in the exact order presented in this manual, or damage could be done to the switch.

IMPORTANT: Before proceeding with functional tests, read and make sure all instructions and information in this section are understood. Also read the information and instructions of labels and decals affixed to the switch. Note any options or accessories that might be installed and review their operation.

## 3.2 MANUAL OPERATION



⚠ Do NOT manually transfer under load. Disconnect transfer switch from all power sources by approved means, such as the main circuit breaker(s).

A manual HANDLE is shipped with the transfer switch. Manual operation must be checked BEFORE the transfer switch is operated electrically. To check manual operation, proceed as follows:

1. Turn the generator's AUTO/OFF/MANUAL switch to OFF.

Figure 3.1 — Actuating Transfer Switch



Attach handle to the moveable contact carrier arm.

**NOTE:** Return handle to storage position in enclosure when finished with manual transfer.

Move handle UP for the NORMAL (UTILITY) position.



Move handle DOWN for the GENERATOR (STANDBY) position.



2. Turn OFF both UTILITY (service disconnect circuit breaker) and GENERATOR (generator disconnect circuit breaker) power supplies to the transfer switch.
3. Note position of transfer mechanism main contacts by observing the moveable contact carrier arm. This can be viewed through the long narrow slot in the inside cover of the ATS. The top of the moveable contact carrier arm is yellow to be easily identified.
  - Manual operation handle in the UP position - LOAD terminals (T1, T2) are connected to UTILITY terminals (N1, N2).
  - Manual operation handle in the DOWN position - LOAD terminals (T1, T2) are connected to EMERGENCY terminals (E1, E2).

—▲ CAUTION ▲—

▲ Do not use excessive force when operating the transfer switch manually or damage could be done to the manual handle.

### ◆ 3.2.1 CLOSE TO UTILITY SOURCE SIDE

Before proceeding, verify the position of the switch by observing the position of manual operation handle in Figure 3.1. If the handle is UP, the contacts are closed in the NORMAL (UTILITY) position, no further action is required. If the handle is DOWN, proceed with Step 1.

Step 1: With the handle inserted into the moveable contact carrier arm, move handle UP. Be sure to hold on to the handle as it will move quickly after the center of travel.

Step 2: Remove manual operating handle from moveable contact carrier arm. Return handle to storage bracket.

### ◆ 3.2.2 CLOSE TO GENERATOR SOURCE SIDE

Before proceeding, verify the position of the switch by observing the position of the manual operation handle in Figure 3.1. If the handle is DOWN, the contacts are closed in the GENERATOR (STANDBY) position. No further action is required. If the handle is UP, proceed with Step 1.

Step 1: With the handle inserted into the moveable contact carrier arm, move the handle DOWN. Be sure to hold on to the handle as it will move quickly after the center of travel.

Step 2: Remove manual operating handle from moveable contact carrier arm. Return handle to storage bracket.

### ◆ 3.2.3 RETURN TO UTILITY SOURCE SIDE

Step 1: Manually actuate switch to return manual operating handle to the UP position.

Step 2: Remove manual operating handle from moveable contact carrier arm. Return handle to storage bracket.

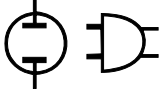

### 3.3 VOLTAGE CHECKS

1. Turn ON the UTILITY power supply to the transfer switch using the UTILITY SERVICE DISCONNECT circuit breaker.



**PROCEED WITH CAUTION. THE TRANSFER SWITCH IS NOW ELECTRICALLY HOT. CONTACT WITH LIVE TERMINALS RESULTS IN EXTREMELY HAZARDOUS AND POSSIBLY FATAL ELECTRICAL SHOCK.**

2. With an accurate AC voltmeter, check for correct voltage. Measure across ATS terminal lugs N1 and N2. Also check N1 to NEUTRAL and N2 to NEUTRAL.
3. When certain that UTILITY supply voltage is correct and compatible with transfer switch ratings, turn OFF the UTILITY supply to the transfer switch.
4. On the generator panel, set the AUTO/OFF/MANUAL switch to MANUAL position. The generator should crank and start.
5. Let the generator stabilize and warm up at no-load for at least five minutes.
6. Turn the GENERATOR DISCONNECT CIRCUIT BREAKER to the ON position.
7. Set the generator's main circuit breaker (CB1) to its ON or CLOSED position.



**PROCEED WITH CAUTION. GENERATOR OUTPUT VOLTAGE IS NOW BEING DELIVERED TO TRANSFER SWITCH TERMINALS. CONTACT WITH LIVE TERMINALS RESULTS IN EXTREMELY DANGEROUS AND POSSIBLY FATAL ELECTRICAL SHOCK.**

8. With an accurate AC voltmeter and frequency meter, check the no-load, voltage and frequency. Measure across ATS terminal lugs E1 to E2. Also check E1 to NEUTRAL and E2 to NEUTRAL.
  - a. Frequency ..... 60-62 Hertz
  - b. Terminals E1 to E2 ..... 240-246 VAC
  - c. Terminals E1 to NEUTRAL..... 120-123 VAC
  - d. Terminals E2 to NEUTRAL..... 120-123 VAC
9. Set the generator's main circuit breaker (CB1) to its OFF or OPEN position.
10. Set the AUTO/OFF/MANUAL switch to the OFF position to shut down the generator.

**NOTE:**

**Do NOT proceed until generator AC output voltage and frequency are correct and within stated limits. If the no-load voltage is correct but no-load frequency is incorrect, the engine governed speed may require adjustment. If no-load frequency is correct but voltage is not, the voltage regulator may require adjustment.**

### 3.4 GENERATOR TESTS UNDER LOAD

1. Set the generator's main circuit breaker to its OFF or OPEN position.
2. Set the UTILITY SERVICE DISCONNECT circuit breaker to the OFF position.
3. Manually actuate the transfer switch main contacts to their GENERATOR (STANDBY) position. Refer to Manual Operation (Section 3.2).
4. To start the generator, set the AUTO/OFF/MANUAL switch to MANUAL. When engine starts, let it stabilize for a few minutes.
5. Turn the GENERATOR DISCONNECT CIRCUIT BREAKER to the ON position.
6. Turn the generator's main circuit breaker to its ON or CLOSED position. The generator now powers all LOAD circuits. Check generator operation under load as follows:
  - Turn ON electrical loads to the full rated wattage/ampere capacity of the generator. DO NOT OVERLOAD.
  - With maximum rated load applied, check voltage and frequency across transfer switch terminals E1 and E2. Voltage should be greater than 230VAC and frequency should be greater than 59 Hertz.
  - Let the generator run under rated load for at least 30 minutes. With unit running, listen for unusual noises, vibration, overheating, etc., that might indicate a problem.
7. When checkout under load is complete, set main circuit breaker of the generator to its OFF or OPEN position.
8. Let the generator run at no-load for several minutes. Then, shut down by setting the AUTO/OFF/MANUAL switch to its OFF position.
9. Turn the GENERATOR DISCONNECT circuit breaker to the ON position.
10. Move the switch's main contacts back to their UTILITY position. For example, LOAD connected to UTILITY power supply. Refer to Manual Operation (Section 3.2). Handle and operating lever of transfer switch should be in UP position.
11. Turn on the utility power supply to transfer switch, using the UTILITY SERVICE DISCONNECT circuit breaker. The utility power source now powers the loads.
12. Set the generator's AUTO/OFF/MANUAL switch to its AUTO position.
13. Set the GENERATOR DISCONNECT SWITCH to the ON position. The system is now set for fully automatic operation.



Section 4 – Installation Diagram

RTS "HS" Type Transfer Switch

Drawing No. 0F0016-C

INSTALLATION

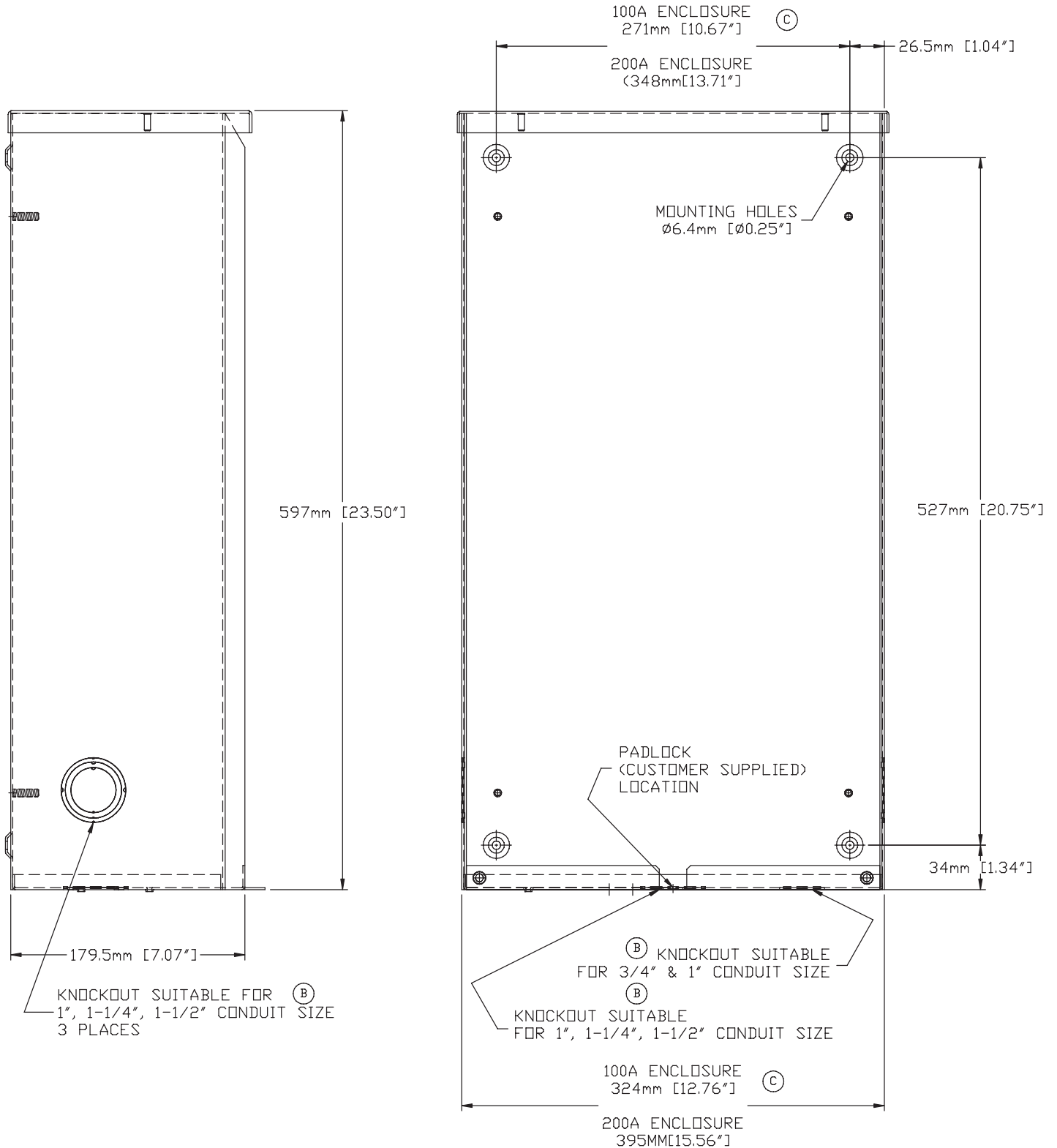
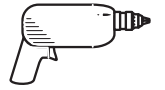

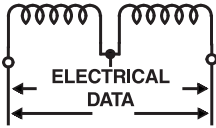

**Section 5 – Electrical Data**

**RTS "HS" Type Transfer Switch**

**Transfer Switch Interconnections - Drawing No. 0G0407-A**

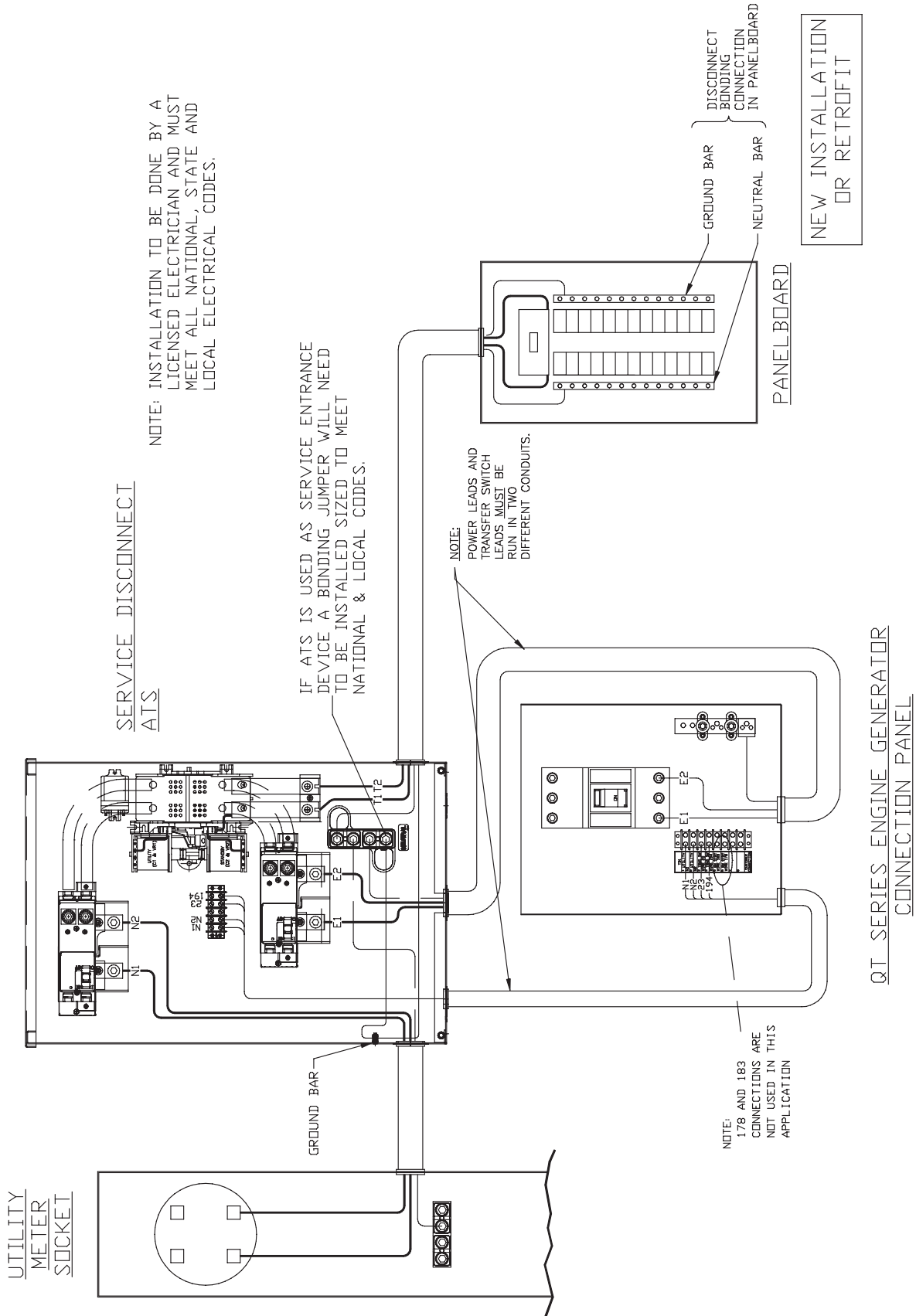

Section 5 – Electrical Data

RTS "HS" Type Transfer Switch

Transfer Switch Interconnections - Drawing No. 0G0407-A

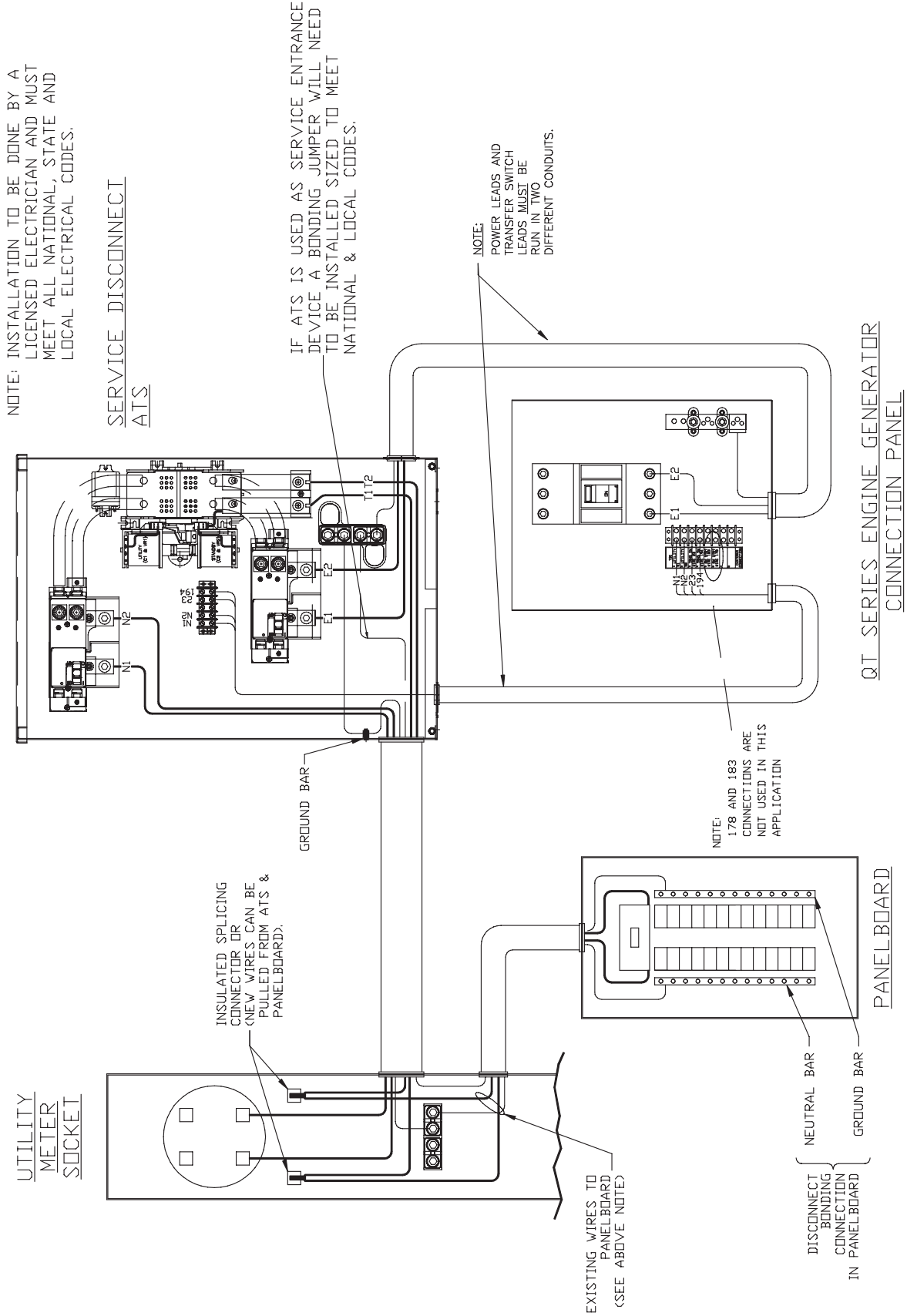
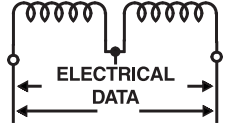

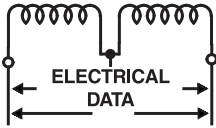

**Section 5 – Electrical Data**

**RTS "HS" Type Transfer Switch**

**Wiring Diagram/Schematic - Drawing No. 0F9994**

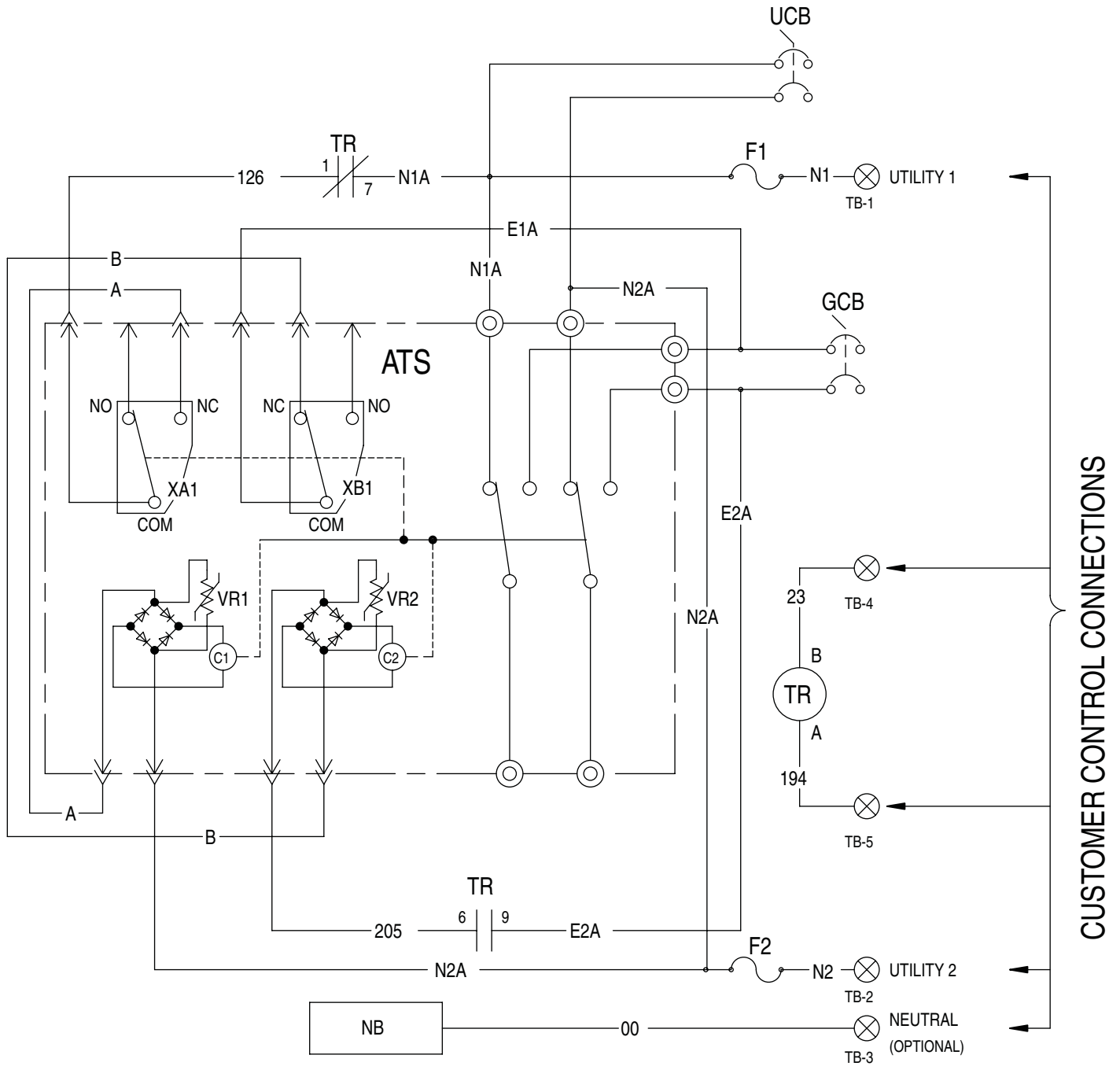

NOTE:  
ALL CONTACTS SHOWN WITH  
TRANSFER SWITCH IN UTILITY  
POSITION.

| LEGEND  |                                      |
|---------|--------------------------------------|
| ATS     | TRANSFER SWITCH CONTACTOR            |
| C1      | SOLENOID COIL (UTILITY CLOSING)      |
| C2      | SOLENOID COIL (STANDBY CLOSING)      |
| F1,F2   | FUSE, 5A                             |
| GCB     | GENERATOR CIRCUIT BREAKER            |
| NB      | NB - NEUTRAL BLOCK                   |
| TB      | TERMINAL STRIP (CUSTOMER CONNECTION) |
| TR      | RELAY, TRANSFER                      |
| UCB     | UTILITY CIRCUIT BREAKER              |
| VR1,VR2 | VARISTOR                             |
| XA1,XB1 | LIMIT SWITCHES, ACTUATOR             |

**Section 5 – Electrical Data**  
**RTS "HS" Type Transfer Switch**  
**Wiring Diagram/Schematic - Drawing No. 0F9994**

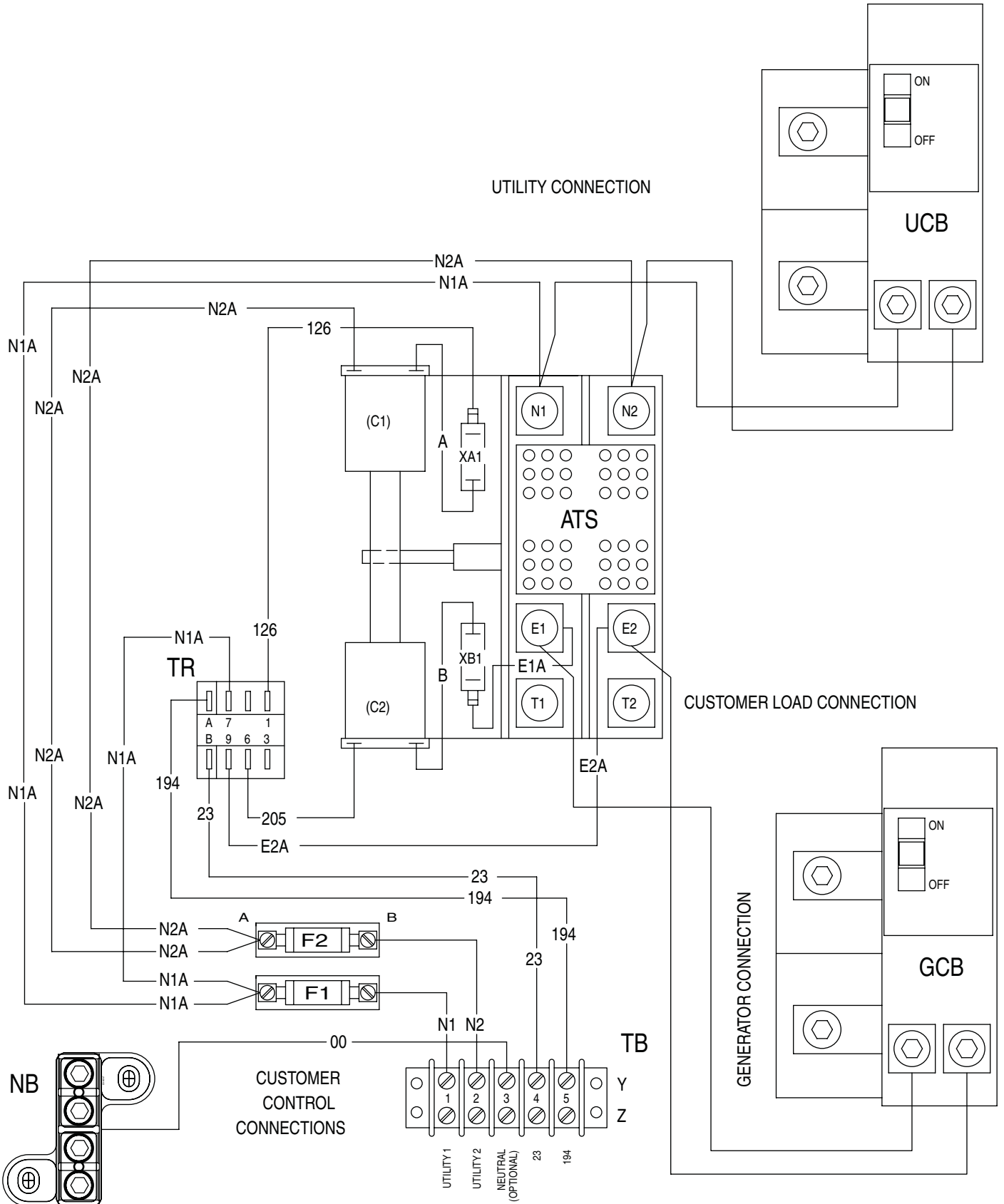
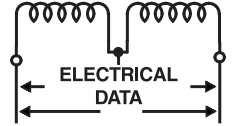

**Section 6 – Exploded Views and Parts List**

**RTS "HS" Type Transfer Switch**

**100A Transfer Switch Assembly – Drawing No. 0G0352\$**

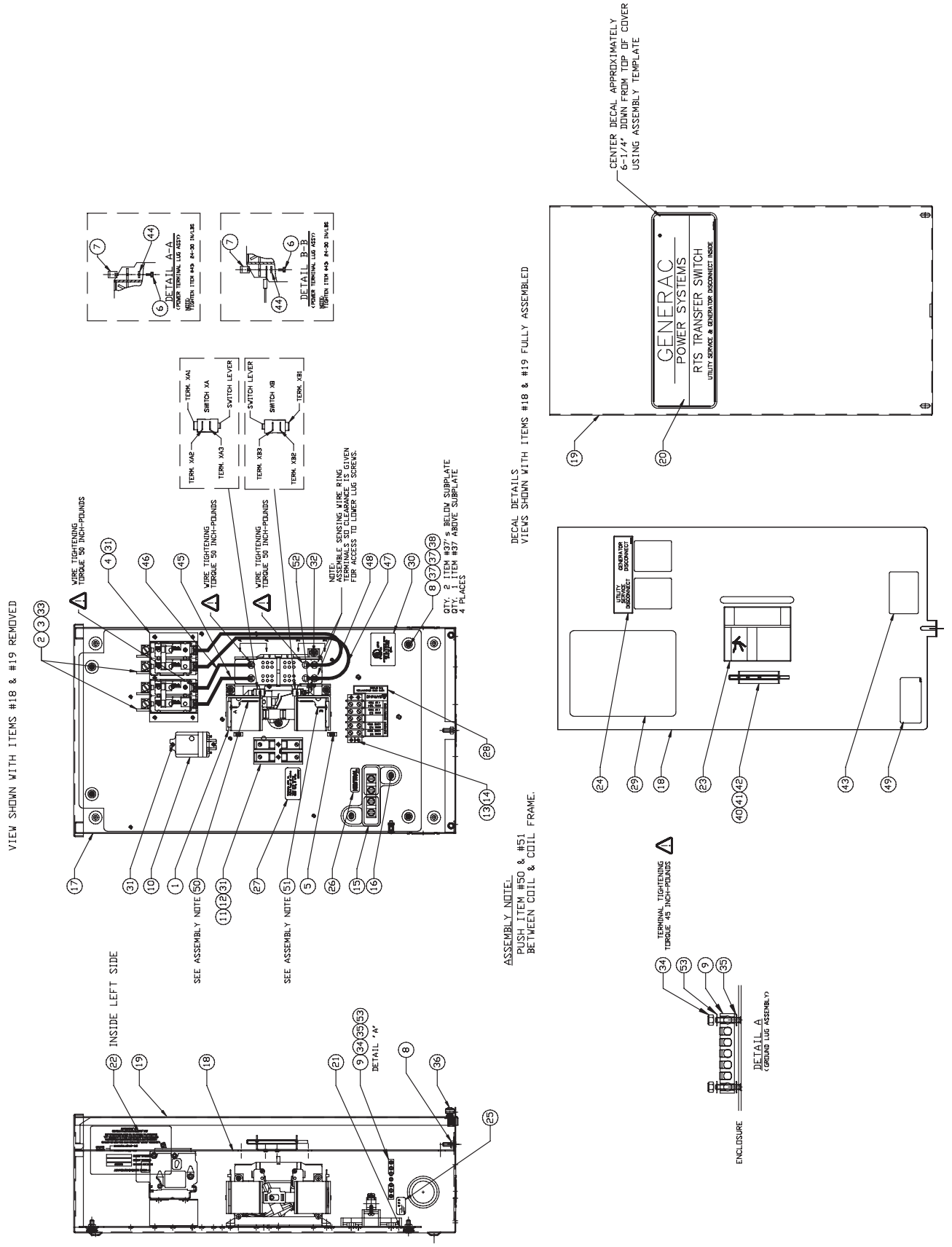

## Section 6 – Exploded Views and Parts List

### RTS "HS" Type Transfer Switch

#### 100A Transfer Switch Assembly – Drawing No. 0G0352\$

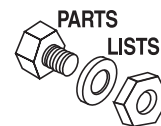

| ITEM  | PART NO. | QTY. | DESCRIPTION                        |
|-------|----------|------|------------------------------------|
| 1     | 0C2237   | 1    | TR SW-HSB 100A 2P 250V             |
| 2     | 0E7886H  | 2    | CB 100A 2P BACK MNT SIEMENS        |
| 3     | 0E7890   | 2    | C/BKR MOUNTING BRACKET             |
| 4     | 0G0160   | 1    | RISER 100 AMP CIRCUIT BREAKERS     |
| 5     | 063378   | 2    | HOLDER CABLE TIE                   |
| 6     | 036933   | 6    | SCREW, PPHMS 10-32 X 3/8"          |
| 7     | 077033   | 6    | LUG, SOLDERLESS                    |
| 8     | 049813   | 5    | NUT HEX M6 X 1.0 G8 YEL CHR        |
| 9     | 0E6523   | 1    | GROUND BAR (5) 4-14 AWG CONN       |
| 10*** | 063617   | 1    | RELAY PNL 12VDC DPDT               |
| 11*** | 0D2806   | 1    | FUSEBLOCK 30A 600V 2 POLE          |
| 12    | 073590A  | 2    | FUSE 5A X BUSS HLDR73591           |
| 13    | 048850   | 1    | BLOCK, TERM 20A 5 X 6              |
| 14    | 0A1661   | 2    | RIVET, POP .156 X .67              |
| 15    | 0C4449   | 1    | ASS'Y NEUTRAL BLOCK 100A           |
| 16    | 090388   | 2    | SCREW HHTT M6-1.0 X 12 MM          |
| 17    | 0F9940   | 1    | WELDMENT, TRANSFER SWITCH          |
| 18    | 0G0186   | 1    | COVER, INSIDE TRANSFER SWITCH ENCL |
| 19    | 0E1477   | 1    | COVER, TRANSFER SWITCH             |
| 20    | 0G0345   | 1    | DECAL TRANSFER SWITCH RTS SE       |
| 21    | 0F9871   | 1    | SUBPLT, XFER SW HSB                |
| 22    | 0E9734   | REF. | DECAL, DATA                        |
| 23    | 0E3484   | 1    | DECAL, MANUAL OPERATING HANDLE     |
| 24    | 0G0195   | 1    | DECAL,UTILITY/GENERATOR DISCONNECT |
| 25    | 067210A  | 1    | DECAL, GROUNDING LUG (NOT SHOWN)   |
| 26    | 0A9457   | 1    | DECAL, NEUTRAL                     |
| 27    | 0D3587   | 1    | DECAL, FUSE REPLACEMENT            |
| 28    | 0C2262   | 1    | DECAL, TERMINAL STRIP              |
| 29    | 0F0776   | 1    | DECAL, TEST SEQUENCE               |
| 30    | 081221   | 1    | DECAL-UL LIST HSB                  |
| 31    | 045764   | 8    | SCREW HHTT M4-.7 X 8 BP            |
| 32    | 066849   | 4    | SCREW HHTT M5-0.8 X 16             |
| 33    | 066849B  | 4    | SCREW HHTT M5-0.8 X 8 BP           |
| 34    | 0C6748   | 2    | NUT HEX LOCK M4-0.7 SS NYL INS     |
| 35    | 026579   | 2    | WASHER SHAKEPROOF EXT #8 STEEL     |
| 36    | 0E7213   | 2    | THUMB SCREW 1/4-20x1/2             |
| 37    | 022473   | 8    | WASHER FLAT 1/4-M6 ZINC            |
| 38    | 022097   | 4    | WASHER LOCK M6-1/4                 |
| 39    | 0G0197   | 1    | WIRING HARNESS HSB (NOT SHOWN)     |
| 40    | 0E6193   | 1    | BRACKET, ARM EXTENDER              |
| 41    | 064526   | 2    | SCREW HWHS #6-25 X 3/8 ZNC         |
| 42**  | 0E6155   | 1    | ARM EXTENDER PIN                   |
| 43    | 0C8308   | 1    | DECAL,TERMINAL SHOCK               |
| 44    | 022152   | 6    | WASHER, LOCK # 10                  |
| 45    | 0G0204A  | 1    | WIRE ASM, 2AWG 100A 2-P T/S N1A    |
| 46    | 0G0204B  | 1    | WIRE ASM, 2AWG 100A 2-P T/S N2A    |
| 47    | 0G0204C  | 1    | WIRE ASM, 2AWG 100A 2-P T/S E1A    |
| 48    | 0G0204D  | 1    | WIRE ASM, 2AWG 100A 2-P T/S E2A    |
| 49    | 095282   | 1    | DECAL, LIVE-CIRCUIT                |
| 50    | 0E6303   | 1    | WIRE-A                             |
| 51    | 0E6303A  | 1    | WIRE-B                             |
| 52    | 0E6303C  | 1    | WIRE-E1                            |
| 53    | 043180   | 2    | WASHER FLAT M4                     |

\*\* SUPPLIED WITH TRANSFER SWITCH ITEM #1

\*\*\* SUPPLIED WITH WIRE HARNESS ITEM #39



## Section 6 – Exploded Views and Parts List

### RTS "HS" Type Transfer Switch

#### 200A Transfer Switch Assembly – Drawing No. 0G0351\$-A

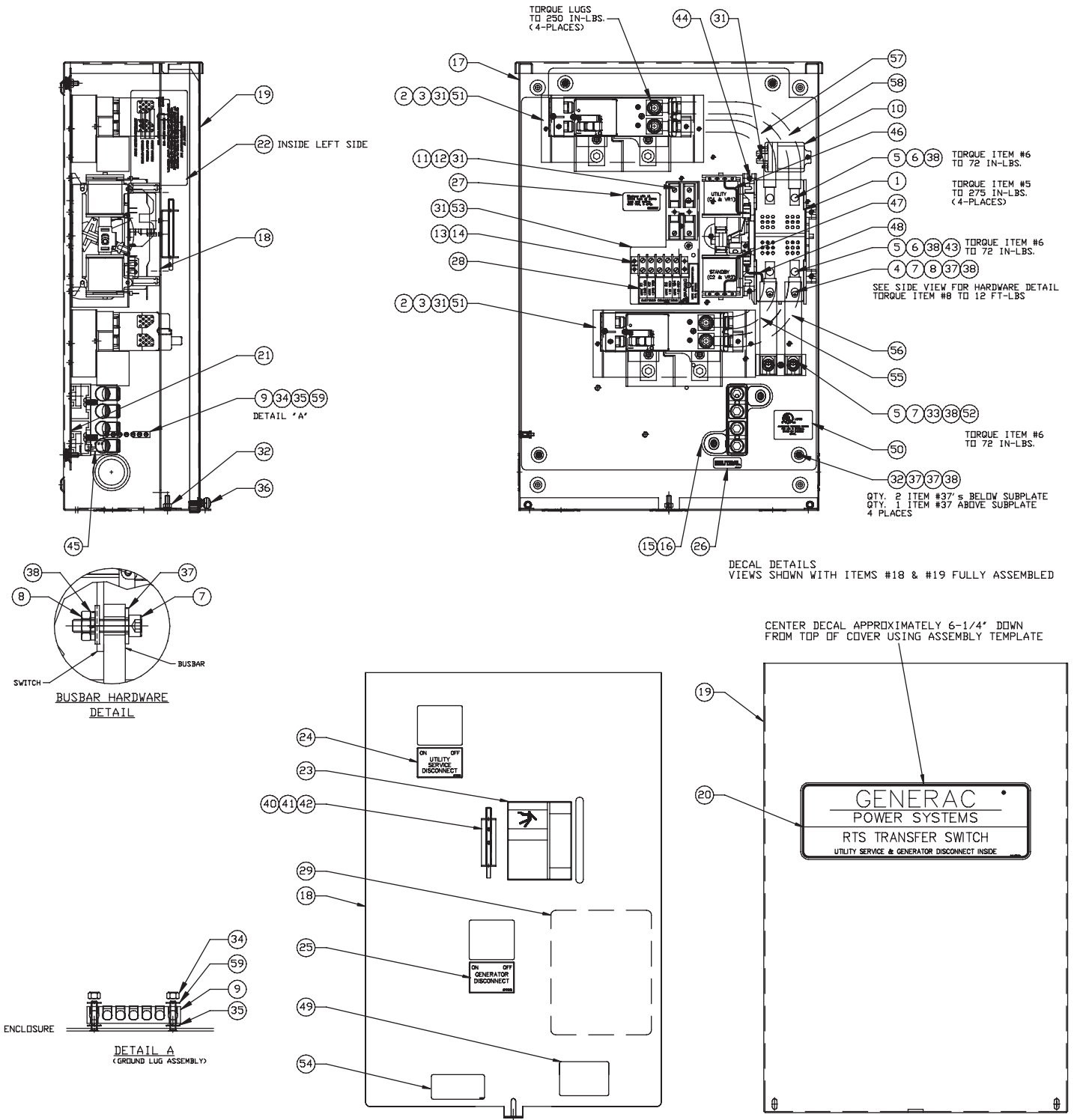



**Section 6 – Exploded Views and Parts List**

**RTS "HS" Type Transfer Switch**

**200A Transfer Switch Assembly – Drawing No. 0G0351\$-A**

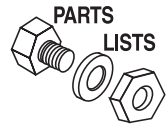

| ITEM | PART NO. | QTY. | DESCRIPTION                     | ITEM | PART NO. | QTY. | DESCRIPTION                             |
|------|----------|------|---------------------------------|------|----------|------|---|
| 1    | 0D9618   | 1    | TRANSFER SW. HSB 200A 2P 250V   | 32   | 049813   | 5    | NUT HEX M6 X 1.0 G8 YEL CHR             |
| 2    | 0E3628   | 2    | CIRCUIT BREAKER, 200A 2-POLE    | 33   | 0C2695   | 1    | SCREW PHTT M4-0.7 X 20 ZYC              |
| 3    | 0E3664   | 2    | BASE,CIRCUIT BREAKER 2-POLE     | 34   | 0C6748   | 2    | NUT HEX LOCK M4-0.7 SS NYL INS          |
| 4    | 0F9857   | 2    | BUSBAR, 200A HSB XFER SW        | 35   | 026579   | 2    | WASHER SHAKEPROOF EXT #8 STEEL          |
| 5    | 0E3375   | 6    | LUG SOLDERLESS 250-#6 AL/CU     | 36   | 0E7213   | 2    | THUMB SCREW 1/4-20x1/2                  |
| 6    | 0F1252   | 4    | SCREW BHSC 1/4-20 X 3/8"        | 37   | 022473   | 14   | WASHER FLAT 1/4-M6 ZINC                 |
| 7    | 036781   | 4    | SCREW SHC 1/4-20 X 3/4"         | 38   | 022097   | 12   | WASHER LOCK M6-1/4                      |
| 8    | 022127   | 2    | NUT 1/4-20                      | 39   | 0G0111   | 1    | WIRING HARNESS HSB (NOT SHOWN)          |
| 9    | 0E6523   | 1    | GROUND BAR (5) 4-14 AWG CONN    | 40   | 0E6193   | 1    | BRACKET, ARM EXTENDER                   |
| 10** | 063617   | 1    | RELAY PNL 12VDC DPDT            | 41   | 064526   | 2    | SCREW HWHS #6-25 X 3/8                  |
| 11** | 0D2806   | 1    | FUSEBLOCK 30A 600V 2 POLE       | 42*  | 0E6155   | 1    | ARM EXTENDER PIN                        |
| 12   | 073590A  | 2    | FUSE 5A X BUSS HLDR73591        | 43*  | 0E6033   | 1    | 90 DEGREE DN SPADE CONNECTOR            |
| 13** | 048850   | 1    | BLOCK TERM 20A 5 X 6 X 1100V    | 44   | 066849   | 5    | SCREW HHTT M5-0.8 X 16                  |
| 14   | 0A1661   | 2    | RIVET, POP .156 X .67           | 45   | 067210A  | 1    | DECAL, GROUNDING LUG (NOT SHOWN)        |
| 15   | 0C4449A  | 1    | ASS'Y NEUTRAL BLOCK 200A        | 46   | 0E6303   | 1    | WIRE-A                                  |
| 16   | 090388   | 2    | SCREW HHTT M6-1.0 X 12 MM       | 47   | 0E6303A  | 1    | WIRE-B                                  |
| 17   | 0G1018   | 1    | WELDMENT,TRANSFER SWITCH ENCL   | 48   | 0E6303B  | 1    | WIRE-E1                                 |
| 18   | 0G1035   | 1    | COVER, INSIDE 200A DUAL BREAKER | 49   | 0C8308   | 1    | DECAL,TERMINAL SHOCK                    |
| 19   | 0G1034   | 1    | COVER, TRANSFER SWITCH          | 50   | 0G0900   | 1    | DECAL-UL LIST HSB                       |
| 20   | 0G0345   | 1    | DECAL TRANSFER SWITCH RTS SE    | 51   | 0F9843   | 2    | RISER, CIRCUIT BREAKER                  |
| 21   | 0G0136   | 1    | SUBPLT,XFER SW HSB SERV ENT     | 52   | 0F9856   | 1    | BLOCK, PHENOLIC                         |
| 22   | 0E3477   | REF. | DECAL, DATA                     | 53   | 0F9851   | 1    | FUSE BRACKET                            |
| 23   | 0E3484   | 1    | DECAL, MANUAL OPERATING HANDLE  | 54   | 095282   | 1    | DECAL-LIVE CIRCUIT                      |
| 24   | 0F9969   | 1    | DECAL, UTILITY DISCONNECT       | 55   | 0G0011B  | 1    | WIRE, RED, 3/0 E1                       |
| 25   | 0F9970   | 1    | DECAL, GENERATOR DISCONNECT     | 56   | 0G0011A  | 1    | WIRE, RED, 3/0 E2                       |
| 26   | 0A9457   | 1    | DECAL, NEUTRAL                  | 57   | 0G0011D  | 1    | WIRE, BLACK, 3/0 N1                     |
| 27   | 0D3587   | 1    | DECAL, FUSE REPLACEMENT         | 58   | 0G0011C  | 1    | WIRE, BLACK, 3/0 N2                     |
| 28   | 0C2262   | 1    | DECAL, TERMINAL STRIP           | 59   | 043180   | 2    | WASHER FLAT M4                          |
| 29   | 0E7109   | 1    | DECAL, TEST SEQUENCE            |      |          |      |   |
| 30   | 063378   | 2    | HOLDER CABLE TIE (NOT SHOWN)    |      |          |      | * SUPPLIED WITH TRANSFER SWITCH ITEM #1 |
| 31   | 045764   | 11   | SCREW HHTT M4-.7 X 8 BP         |      |          |      | ** SUPPLIED WITH HARNESS ITEM #39       |



**Section 7 – Notes**  
**RTS “HS” Type Transfer Switch**

**NOTES**



## **GENERAC POWER SYSTEMS, INC. WARRANTY/SERVICE**

Generac Power Systems, Inc. will warrant that from the date of purchase, our transfer switch will be free from defects in material and workmanship for the items and periods set forth in the warranty statement found in the owners manual of the Generac Power Systems Inc. generator that this transfer switch will be utilized with.

Any equipment that the purchaser/owner claims to be defective must be examined by the nearest Generac Authorized Warranty Service Dealer by visiting our website at [www.generac.com](http://www.generac.com) or by calling the dealer locator number at 1-800-333-1322. Select the prompt that describes the brand name of the generator.

THIS WARRANTY IS IN PLACE OF ALL OTHER WARRANTIES, EXPRESSED OR IMPLIED, SPECIFICALLY, GENERAC MAKES NO OTHER WARRANTIES AS TO THE MERCHANTABILITY OR FITNESS FOR A PARTICULAR PURPOSE.

Some states do not allow limitations on how long an implied warranty lasts, so the above limitation may not apply to you.

GENERAC'S ONLY LIABILITY SHALL BE THE REPAIR OR REPLACEMENT OF PART(S) AS STATED ABOVE. IN NO EVENT SHALL GENERAC POWER SYSTEMS, INC. BE LIABLE FOR ANY INCIDENTAL, OR CONSEQUENTIAL DAMAGES, EVEN IF SUCH DAMAGES ARE A DIRECT RESULT OF GENERAC'S NEGLIGENCE.

Some states do not allow the exclusion or limitation of incidental or consequential damages, so the above limitations may not apply to you.

This warranty gives you specific legal rights. You also may have other rights that vary from state to state.

**GENERAC® POWER SYSTEMS, INC.**

**P.O. BOX 297 · WHITEWATER, WI 53190**