

Serial Number

**2.4L
22/27kW
Models
EPA Certified**

**STATIONARY EMERGENCY GENERATOR
OWNER'S MANUAL**

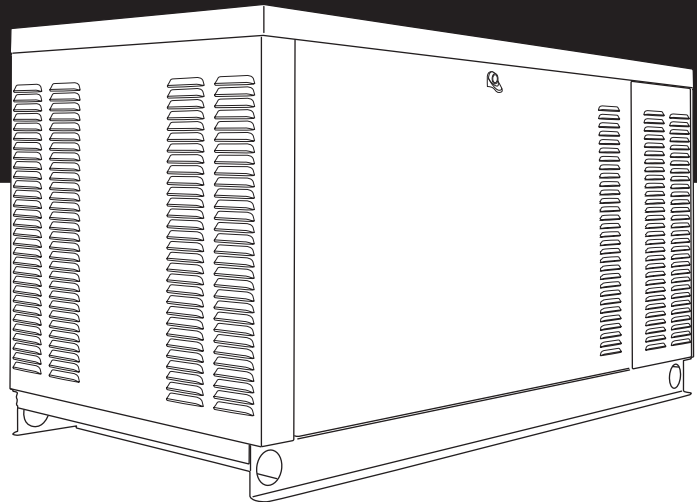

A new standard of reliability

⚠ Not intended for use in critical life support applications. ⚠



— ⚠ **CAUTION** ⚠ —

ONLY QUALIFIED ELECTRICIANS OR CONTRACTORS SHOULD ATTEMPT INSTALLATION!
DEADLY EXHAUST FUMES. OUTDOOR INSTALLATION ONLY!

This manual should remain with the unit.

SECTION	PAGE		
INTRODUCTION	1-1	Initial Inspection for Genset Start-up	8-1
Read this Manual Thoroughly	1-1	Start-up Checklist	8-2
Operation and Maintenance	1-1	Preparation for Start-up.....	8-2
How to Obtain Service	1-1	OPERATION	9-1
SAFETY RULES	1-2	Stationary Emergency Generator Control and Operation.....	9-1
IDENTIFICATION RECORD	2-1	Operating Unit with Manual Transfer Switch.....	9-1
Data Label	2-1	Engine Start-up and Transfer	9-1
EQUIPMENT DESCRIPTION	3-1	Retransfer and Shutdown.....	9-1
Equipment Description	3-1	Operating Unit with Automatic Transfer Switch	9-1
Engine Oil Recommendations.....	3-1	MAINTENANCE	10-1
Coolant Recommendations	3-1	Maintenance Performed by Service Dealers/Contractors.....	10-1
ENGINE PROTECTIVE DEVICES	4-1	Every Three Months	10-1
Engine Protective Devices	4-1	Once Every Six Months	10-1
High Coolant Temperature Switch.....	4-1	Once Annually.....	10-1
Low Coolant Level Sensor.....	4-1	First 30 Operating Hours	10-1
Low Oil Pressure Switch	4-1	First 100 Operating Hours	10-1
Overcrank Shutdown.....	4-1	Every 500 Operating Hours	10-1
Overspeed Shutdown	4-1	Cooling System.....	10-1
RPM Sensor Loss Shutdown.....	4-1	Overload Protection for Engine DC Electrical System	10-1
DC Fuses	4-1	Checking Fluid Levels.....	10-1
FUEL SYSTEMS	5-1	Check Engine Oil.....	10-1
Fuel Requirements	5-1	Battery Fluid.....	10-2
Natural Gas Fuel System	5-1	Engine Coolant.....	10-2
Propane Vapor Withdrawal Fuel System.....	5-1	Maintenance Owner/Operator Can Perform.....	10-2
LP Liquid Fuel System.....	5-1	Check Engine Oil Level.....	10-2
SPECIFICATIONS	6-1	Check Battery	10-2
Stationary Emergency Generator	6-1	Exercise System	10-2
Engine	6-1	Inspect Cooling System	10-2
Cooling System.....	6-1	Check Engine Coolant Level	10-2
Fuel System.....	6-1	Perform Visual Inspection	10-2
Electrical System	6-1	Inspect Exhaust System	10-2
Weather and Maintenance Kits	6-2	Check Fan Belt.....	10-2
Reconfiguring the Fuel System	6-2	Inspect Engine Governor	10-3
Fuel System	6-2	Changing Engine Oil.....	10-3
Control Panel	6-3	Changing the Engine Air Filter.....	10-3
GENERAL INFORMATION	7-1	Spark Plugs	10-4
Alternator AC Lead Connections.....	7-1	Coolant Change	10-4
Four-lead, Single-phase Stator.....	7-1	Miscellaneous Maintenance	10-4
Alternator Power Winding Connections	7-1	Cleaning the Stationary Emergency Generator	10-4
3-phase Alternators.....	7-1	Battery.....	10-4
INSTALLATION	8-1	Battery Maintenance	10-4
Installation	8-1	Battery Replacement.....	10-5
Preparation Before Start-up.....	8-1	Repair Parts.....	10-5
Transfer Switch.....	8-1	SERVICE SCHEDULE	11-1
Fuel System	8-1	TROUBLESHOOTING	12-1
Generator Set Lubrication.....	8-1	Troubleshooting Guide.....	12-1
Prior to Initial Start-up.....	8-1	EMISSIONS WARRANTY	13-1
Engine Coolant.....	8-1	NOTES	
Belt Tension	8-1	EXPLODED VIEWS & PARTS LISTS	
Electrical System	8-1	WIRING DIAGRAMS & SCHEMATICS	



 **SAVE THESE INSTRUCTIONS** – The manufacturer suggests that these rules for safe operation be copied and posted in potential hazard areas. Safety should be stressed to all operators, potential operators, and service and repair technicians  for this equipment.

INTRODUCTION

Thank you for purchasing this model of the stationary emergency generator product line.

Every effort was expended to make sure that the information and instructions in this manual were both accurate and current at the time the manual was written. However, the manufacturer reserves the right to change, alter or otherwise improve this product(s) at any time without prior notice.

◆ READ THIS MANUAL THOROUGHLY

If any portion of this manual is not understood, contact the nearest Service Dealer for starting, operating and servicing procedures.

Throughout this publication, and on tags and decals affixed to the generator, DANGER, WARNING, CAUTION and NOTE blocks are used to alert personnel to special instructions about a particular service or operation that may be hazardous if performed incorrectly or carelessly. Observe them carefully. Their definitions are as follows:



After this heading, read instructions that, if not strictly complied with, will result in serious personal injury, including death, or property damage.



After this heading, read instructions that, if not strictly complied with, may result in personal injury or property damage.



After this heading, read instructions that, if not strictly complied with, could result in damage to equipment and/or property.

NOTE:

After this heading, read explanatory statements that require special emphasis.

These safety warnings cannot eliminate the hazards that they indicate. Common sense and strict compliance with the special instructions while performing the service are essential to preventing accidents.

Four commonly used safety symbols accompany the DANGER, WARNING and CAUTION blocks. The type of information each indicates is as follows:

 **This symbol points out important safety information that, if not followed, could endanger personal safety and/or property of others.**

 **This symbol points out potential explosion hazard.**

 **This symbol points out potential fire hazard.**

 **This symbol points out potential electrical shock hazard.**

The operator is responsible for proper and safe use of the equipment. The manufacturer strongly recommends that the operator read this Owner's Manual and thoroughly understand all instructions before using this equipment. The manufacturer also strongly recommends instructing other users to properly start and operate the unit. This prepares them if they need to operate the equipment in an emergency.

For safety reasons, the manufacturer recommends that this equipment be installed, serviced and repaired by a Service Dealer or other competent, qualified electrician or installation technician who is familiar with applicable codes, standards and regulations. The operator also must comply with all such codes, standards and regulations.

◆ OPERATION AND MAINTENANCE

It is the operator's responsibility to perform all safety checks, to make sure that all maintenance for safe operation is performed promptly, and to have the equipment checked periodically by a Service Dealer. Normal maintenance service and replacement of parts are the responsibility of the owner/operator and, as such, are not considered defects in materials or workmanship within the terms of the warranty. Individual operating habits and usage contribute to the need for maintenance service.

Proper maintenance and care of the generator ensure a minimum number of problems and keep operating expenses at a minimum. See a Service Dealer for service aids and accessories.

Operating instructions presented in this manual assume that the generator electric system has been installed by a Service Dealer or other competent, qualified contractor. Installation of this equipment is not a "do-it-yourself" project.

◆ HOW TO OBTAIN SERVICE

When the generator requires servicing or repairs, simply contact a Service Dealer for assistance. Service technicians are factory-trained and are capable of handling all service needs.

When contacting a dealer about parts and service, always supply the complete Model Number, Serial Number and Type Code (where applicable) from the DATA LABEL that is affixed to the unit.



WARNING:



The engine exhaust from this product contains chemicals known to the state of California to cause cancer, birth defects or other reproductive harm.



WARNING:



This product contains or emits chemicals known to the state of California to cause cancer, birth defects or other reproductive harm.

Study these SAFETY RULES carefully before installing, operating or servicing this equipment. Become familiar with this Owner's Manual and with the unit. The generator can operate safely, efficiently and reliably only if it is properly installed, operated and maintained. Many accidents are caused by failing to follow simple and fundamental rules or precautions.

The manufacturer cannot anticipate every possible circumstance that might involve a hazard. The warnings in this manual, and on tags and decals affixed to the unit are, therefore, not all inclusive. If a procedure, work method or operating technique is used that the manufacturer does not specifically recommend, ensure that it is safe for others. Also make sure the procedure, work method or operating technique utilized does not render the generator unsafe.

— **DANGER** —

Despite the safe design of this generator, operating this equipment imprudently, neglecting its maintenance or being careless can cause possible injury or death. Permit only responsible and capable persons to install, operate or maintain this equipment.

Potentially lethal voltages are generated by these machines. Ensure all steps are taken to render the machine safe before attempting to work on the generator.

Parts of the generator are rotating and/or hot during operation. Exercise care near running generators.

GENERAL HAZARDS

- For safety reasons, the manufacturer recommends that this equipment be installed, serviced and repaired by a Service Dealer or other competent, qualified electrician or installation technician who is familiar with applicable codes, standards and regulations. The operator also must comply with all such codes, standards and regulations.
- Installation, operation, servicing and repair of this (and related) equipment must always comply with applicable codes, standards, laws and regulations. Adhere strictly to local, state and national electrical and building codes. Comply with regulations the Occupational Safety and Health Administration (OSHA) has established. Also, ensure that the generator is installed, operated and serviced in accordance with the manufacturer's instructions and recommendations. Following installation, do nothing that might render the unit unsafe or in noncompliance with the aforementioned codes, standards, laws and regulations.
- The engine exhaust fumes contain carbon monoxide gas, which can be DEADLY. This dangerous gas, if breathed in sufficient concentrations, can cause unconsciousness or even death. For that reason, adequate ventilation must be provided. This should be considered prior to installing the generator. The unit should be positioned to direct exhaust gasses safely away from any building where people, animals, etc., will not be harmed. Any exhaust stacks that ship loose with the unit must be installed properly per the manufacturer's instruction, and in strict compliance with applicable codes and standards.
- Keep hands, feet, clothing, etc., away from drive belts, fans, and other moving or hot parts. Never remove any drive belt or fan guard while the unit is operating.
- Adequate, unobstructed flow of cooling and ventilating air is critical in any room or building housing the generator to prevent buildup of explosive gases and to ensure correct generator operation. Do not alter the installation or permit even partial blockage of ventilation provisions, as this can seriously affect safe operation of the generator.
- Keep the area around the generator clean and uncluttered. Remove any materials that could become hazardous.
- When working on this equipment, remain alert at all times. Never work on the equipment when physically or mentally fatigued.
- Inspect the generator regularly, and promptly repair or replace all worn, damaged or defective parts using only factory-approved parts.
- Before performing any maintenance on the generator, disconnect its battery cables to prevent accidental start-up. Disconnect the cable from the battery post indicated by a NEGATIVE, NEG or (-) first. Reconnect that cable last.
- Never use the generator or any of its parts as a step. Stepping on the unit can stress and break parts, and may result in dangerous operating conditions from leaking exhaust gases, fuel leakage, oil leakage, etc.



ELECTRICAL HAZARDS

- All stationary emergency generators covered by this manual produce dangerous electrical voltages and can cause fatal electrical shock. Utility power delivers extremely high and dangerous voltages to the transfer switch as well as the generator. Avoid contact with bare wires, terminals, connections, etc., on the generator as well as the transfer switch, if applicable. Ensure all appropriate covers, guards and barriers are in place before operating the generator. If work must be done around an operating unit, stand on an insulated, dry surface to reduce shock hazard.
- Do not handle any kind of electrical device while standing in water, while barefoot, or while hands or feet are wet. DANGEROUS ELECTRICAL SHOCK MAY RESULT.
- If personnel must stand on metal or concrete while installing, operating, servicing, adjusting or repairing this equipment, place insulative mats over a dry wooden platform. Work on the equipment only while standing on such insulative mats.
- The National Electrical Code (NEC) requires the frame and external electrically conductive parts of the generator to be connected to an approved earth ground. This grounding will help prevent dangerous electrical shock that might be caused by a ground fault condition in the generator or by static electricity. Never disconnect the ground wire.
- Wire gauge sizes of electrical wiring, cables and cord sets must be adequate to handle the maximum electrical current (ampacity) to which they will be subjected.
- Before installing or servicing this (and related) equipment, make sure that all power voltage supplies are positively turned off at their source. Failure to do so will result in hazardous and possibly fatal electrical shock.
- Connecting this unit to an electrical system normally supplied by an electric utility shall be by means of a transfer switch so as to isolate the generator electric system from the electric utility distribution system when the generator is operating. Failure to isolate the two electric system power sources from each other by such means will result in damage to the generator and may also result in injury or death to utility power workers due to backfeed of electrical energy.
- Stationary emergency generators installed with an automatic transfer switch will crank and start automatically when normal (utility) source voltage is removed or is below an acceptable preset level. To prevent such automatic start-up and possible injury to personnel, disable the generator's automatic start circuit (battery cables, etc.) before working on or around the unit. Then, place a "Do Not Operate" tag on the generator control panel and on the transfer switch.
- In case of accident caused by electric shock, immediately shut down the source of electrical power. If this is not possible, attempt to free the victim from the live conductor. AVOID DIRECT CONTACT WITH THE VICTIM. Use a nonconducting implement, such as a dry rope or board, to free the victim from the live conductor. If the victim is unconscious, apply first aid and get immediate medical help.
- Never wear jewelry when working on this equipment. Jewelry can conduct electricity resulting in electric shock, or may get caught in moving components causing injury.

FIRE HAZARDS

- Keep a fire extinguisher near the generator at all times. Do NOT use any carbon tetra-chloride type extinguisher. Its fumes are toxic, and the liquid can deteriorate wiring insulation. Keep the extinguisher properly charged and be familiar with its use. If there are any questions pertaining to fire extinguishers, consult the local fire department.

EXPLOSION HAZARDS

- Properly ventilate any room or building housing the generator to prevent build-up of explosive gas.
- Do not smoke around the generator. Wipe up any fuel or oil spills immediately. Ensure that no combustible materials are left in the generator compartment, or on or near the generator, as FIRE or EXPLOSION may result. Keep the area surrounding the generator clean and free from debris.
- These generators may operate using one of several types of fuels. All fuel types are potentially FLAMMABLE and/or EXPLOSIVE and should be handled with care. Comply with all laws regulating the storage and handling of fuels. Inspect the unit's fuel system frequently and correct any leaks immediately. Fuel supply lines must be properly installed, purged and leak tested according to applicable fuel-gas codes before placing this equipment into service.
- Diesel fuels are highly FLAMMABLE. Gaseous fluids such as natural gas and liquid propane (LP) gas are extremely EXPLOSIVE. Natural gas is lighter than air, and LP gas is heavier than air; install leak detectors accordingly.

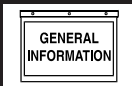

Stationary Emergency Generator General Information

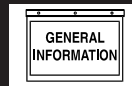

IDENTIFICATION RECORD

◆ DATA LABEL

Every generator set has a DATA LABEL that contains important information pertinent to the generator. The data label, which can be found attached to the generator's lower connection box, lists the unit's serial number and its rated voltage, amps, wattage capacity, phase, frequency, rpm, power factor, production date, etc.

NOTE:

For actual information related to this particular model, please refer to the Manual Drawing Listing located at the end of this manual, or to the data label affixed to the unit.

★ *Stationary Emergency Generator Model and Serial Number*

This number is the key to numerous engineering and manufacturing details pertaining to your unit. Always supply this number when requesting service, ordering parts or seeking information.

Data Label

MODEL	<input type="text"/>	<input type="text"/>
PROD DATE	<input type="text"/>	SERIAL <input type="text"/>
KW <input type="text"/>	KVA <input type="text"/>	PHASE <input type="text"/>
HERTZ <input type="text"/>	VOLT <input type="text"/>	AMP <input type="text"/>
PWR FACT <input type="text"/>	ALT RPM <input type="text"/>	ENG RPM <input type="text"/>
TYPE CODE <input type="text"/>	ALT SUBTRANS REACTANCE <input type="text"/>	ALT TRANS REACTANCE <input type="text"/>
CLASS <input type="checkbox"/> ROTOR <input type="checkbox"/> STATOR WINDING INS AT 25°C AMB		
<input type="text"/>		<input type="text"/>
MODEL NO (CAT/CUST NO)	SERIAL NO	
<input type="text"/>	<input type="text"/>	
<input type="text"/>		<input type="text"/>

0G2110 REV C

EQUIPMENT DESCRIPTION

This equipment is a revolving field, alternating current Stationary Emergency Generator set. It is powered by a gaseous fueled engine operating at 1800 rpm for 4-pole direct drive units, 3600 rpm for 2-pole direct drive units and 2300 - 3000 rpm for quiet drive gear units. See the Specifications section for exact numbers. The unit comes complete with a sound attenuated enclosure, internally mounted muffler, control console, mainline circuit breaker, battery charger, and protective alarms as explained in the following paragraph.

All AC connections, including the power leads from the alternator, 120 volt battery charger input and control connections to the transfer switch are available in the main connection box.

The Stationary Emergency Generator incorporates the following generator features:

- Rotor and Stator insulation is Class H rated as defined by NEMA MG1-32.6, MG1-1.66. The generator is self ventilated and drip-proof constructed.
- The voltage waveform deviation, total harmonic content of the AC waveform and telephone influence factor have been evaluated and are acceptable according to NEMA MG1-32.

ENGINE OIL RECOMMENDATIONS

The unit has been filled with 5W-30 engine oil at the factory. Use a high-quality detergent oil classified "For Service SJ or SH." Detergent oils keep the engine cleaner and reduce carbon deposits. When changing the engine oil, be sure to use 5W-30 engine oil (synthetic oil is recommended).

—▲ CAUTION ▲—

- ▲ Any attempt to crank or start the engine before it has been properly serviced with the recommended oil may result in an engine failure.

NOTE:

For temperatures below 32° F, it is strongly recommended to use the optional Cold Weather Start Kit (part number listed in the Specification Section). The oil grade for temperatures below 32° F is 5W-30 synthetic oil.

COOLANT RECOMMENDATIONS

Use a mixture of half low silicate ethylene glycol base anti-freeze and deionized water. Cooling system capacity is listed in the specifications. Use only deionized water and only low silicate anti-freeze. If desired, add a high quality rust inhibitor to the recommended coolant mixture. When adding coolant, always add the recommended 50-50 mixture.

—▲ CAUTION ▲—

- ▲ Do not use any chromate base rust inhibitor with ethylene glycol base anti-freeze or chromium hydroxide ("green slime") forms and will cause overheating. Engines that have been operated with a chromate base rust inhibitor must be chemically cleaned before adding ethylene glycol base anti-freeze. Using any high silicate anti-freeze boosters or additives will also cause overheating. The manufacturer also recommends that any soluble oil inhibitor is NOT used for this equipment.

—▲ DANGER ▲—

- ▲ Do not remove the radiator pressure cap while the engine is hot or serious burns from boiling liquid or steam could result.
- ▲ Ethylene glycol base antifreeze is poisonous. Do not use mouth to siphon coolant from the radiator, recovery bottle or any container. Wash hands thoroughly after handling. Never store used antifreeze in an open container because animals are attracted to the smell and taste of antifreeze even though it is poisonous to them.

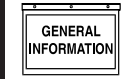
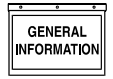

ENGINE PROTECTIVE DEVICES

The Stationary Emergency Generator may be required to operate for long periods of time without an operator on hand to monitor such engine conditions as coolant temperature, oil pressure or rpm. For that reason, the engine has several devices designed to protect it against potentially damaging conditions by automatically shutting down the unit when the oil pressure is too low, the coolant temperature is too high, the coolant level is too low, or the engine is running too fast.

NOTE:

Engine protective switches and sensors are mentioned here for the reader's convenience. Also refer to the applicable control panel manual for additional automatic engine shutdown information.

◆ HIGH COOLANT TEMPERATURE SWITCH

The switch will close if the temperature should exceed approximately 140° C (284° F), initiating an engine shutdown. The generator will automatically restart and the LED will reset once the temperature has returned to a safe operating level.

◆ LOW COOLANT LEVEL SENSOR

To prevent overheating, the engine has a low coolant level sensor. If the level of engine coolant drops below the level of the low coolant level sensor, the engine automatically shuts down.

◆ LOW OIL PRESSURE SWITCH

This switch has normally closed contacts that are held open by engine oil pressure during cranking and operating. Should oil pressure drop below the 8 psi range, switch contacts close, and the engine shuts down. The unit should not be restarted until oil is added, and the AUTO/OFF/MANUAL switch must be turned to OFF and then back to AUTO.

◆ OVERCRANK SHUTDOWN

After a prespecified duration of cranking, this function ends the cranking if the engine has failed to start. The overcrank LED will turn ON. Turn OFF the AUTO/OFF/MANUAL switch, then turn switch back to AUTO to reset the generator control board.

NOTE:

If the fault is not corrected, the overcrank feature will continue to activate.

Approximate Crank Cycle Times

- 15 seconds ON
 - 7 seconds OFF
 - 7 seconds ON
 - 7 seconds OFF
 - Repeat for 45 seconds
- Approximately 90 seconds total.

◆ OVERSPEED SHUTDOWN

A speed circuit controls engine cranking, start-up, operation and shutdown. Engine speed signals are delivered to the circuit board whenever the unit is running. Should the engine overspeed above a safe, preset value, the circuit board initiates an automatic engine shutdown. Contact the nearest Authorized Dealer if this failure occurs.

◆ RPM SENSOR LOSS SHUTDOWN

If the speed signal to the control panel is lost, engine shutdown will occur.

◆ DC FUSES

Fuse F1 (15 amp) is located inside of the control panel. It protects the panel wiring and components from damaging overload. **Always remove this fuse before commencing work on the generator.** The unit will not start or crank if the fuse is blown.

Fuse F2 (25 amp) is located in the engine wire harness adjacent to the DC alternator. It is used to prevent circuit failure due to DC alternator failure. If this fuse is blown, battery charging will not occur while the engine is running. Replace these fuses with the same size, type, and rating. (See the exploded views and parts lists at the end of this manual for replacement part number.)

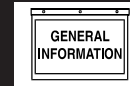
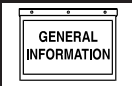

FUEL SYSTEM

◆ FUEL REQUIREMENTS

The Stationary Emergency Generator may be equipped with one of the following fuel systems:

- Natural gas fuel system
- Propane vapor (PV) fuel system
- Liquid propane (LP) fuel system

Recommended fuels should have a Btu content of at least 1,000 Btu's per cubic foot for natural gas; or at least 2,520 Btu's per cubic foot for LP gas. Ask the fuel supplier for the Btu content of the fuel.

Required fuel pressure for **natural gas is 5 inches to 14 inches water column (0.18 to 0.5 psi); and for liquid propane, 5 inches to 14 inches of water column (0.18 to 0.5 psi).**

NOTE:

Any piping used to connect the generator to the fuel supply should be of adequate size to ensure the fuel pressure NEVER drops below five inches water column for natural gas or 5 inches water column for propane vapor for all load ranges. The fuel supply piping shall be sized according to the installation manual using the fuel consumption requirements identified in the Specifications section of the Owner's Manual.

NOTE:

It is the responsibility of the installer to make sure that only the correct recommended fuel is supplied to the generator fuel system. Thereafter, the owner/operator must make certain that only the proper fuel is supplied.

◆ NATURAL GAS FUEL SYSTEM

Natural gas is supplied in its vapor state. In most cases, the gas distribution company provides piping from the main gas distribution line to the standby generator site. The following information applies to natural gas fuel systems.

- Gas pressure in a building is usually regulated by national, state and local codes.
- To reduce gas pressure to a safe level before the gas enters a building, a primary regulator is needed. The natural gas supplier may or may not supply such a regulator.
- It is the responsibility of the gas supplier to make sure sufficient gas pressure is available to operate the primary regulator.
- Gas pressure at the inlet to the fuel shutoff solenoid should not exceed approximately 14 inches water column (0.5 psi).

◆ PROPANE VAPOR WITHDRAWAL FUEL SYSTEM

This type of system utilizes the vapors formed above the liquid fuel in the supply tank. Approximately 10 to 20 percent of the tank capacity is needed for fuel expansion from the liquid to the vapor state. The vapor withdrawal system is generally best suited for smaller engines that require less fuel. The installer should be aware of the following:

- When ambient temperatures are low and engine fuel consumption is high, the vapor withdrawal system may not function efficiently.
- Ambient temperatures around the supply tank must be high enough to sustain adequate vaporization, or the system will not deliver the needed fuel volume.
- In addition to the cooling effects of ambient air, the vaporization process itself provides an additional cooling effect.

◆ LP LIQUID FUEL SYSTEM

LP is supplied as a liquid in pressure tanks. It is usually made up of propane, butane, or a mixture of the two gases. Propane tends to vaporize readily even at temperatures as low as -20° F (-29° C). However, butane reverts to its liquid state when temperatures drop below 32° F (0° C).

LP in a liquid withdrawal system must be converted to its gaseous state before it is introduced into the engine carburetor. A vaporizer-converter is generally used to accomplish this. In such a converter, heated engine coolant is ported through the converter to provide the necessary heat for conversion of the fuel from a liquid to a gaseous state.

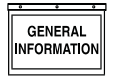

Stationary Emergency Generator Specifications



SPECIFICATIONS

◆ STATIONARY EMERGENCY GENERATOR

Type.....Synchronous
 Rotor Insulation..... Class H
 Stator Insulation..... Class H
 Total Harmonic Distortion..... <5%
 Telephone Interference Factor (TIF) < 50
 Alternator Output Leads 3-phase 4-wire
 Bearings Sealed Ball
 Coupling Flexible Disc
 Load Capacity (Standby Rating) 22/27kW*

* NOTE: Generator rating and performance in accordance with ISO8528-5, BS5514, SAE J1349, ISO3046 and DIN 6271 Standards. KW rating is based on LPG fuel and may derate with natural gas and generator specific settings.

Excitation System Direct
 Generator Output Voltage/kW - 60 Hz

	kW	Amp	CB Size
120/240V, 1-phase, 1.0 pf	22/27	92/113	100/125
120/208V, 3-phase, 0.8 pf	22/27	77/94	80/100
120/240V, 3-phase, 0.8 pf	22/27	66/81	80/90

Generator Locked Rotor KVA Available @ Voltage Dip of 35%

22kW	27kW
38 KVA	42 KVA

◆ ENGINE

Make Generac
 Model In Line
 Cylinders and Arrangement 4
 Displacement 2.4 Liter
 Bore 86.5 mm (3.41 in.)
 Stroke 100 mm (3.94 in.)
 Compression Ratio 9.5-to-1
 Air Intake System Naturally Aspirated
 Valve Seats Hardened
 Lifter Type Hydraulic

Engine Parameters

Rated Synchronous RPM 60 Hz, 1800
 HP at rated kW (22/27kW) 60 Hz, 32-36/38-43

Exhaust System

Exhaust Flow at Rated Output 60 Hz (22/27kW) 165/180 cfm
 Exhaust Temp. at Rated Output (22/27kW) 900°/1000° F

Combustion Air Requirements (Natural Gas)

Flow at rated power, 60 Hz..... 68 cfm

Governor

Type..... Electronic
 Frequency Regulation..... Isochronous
 Steady State Regulation ± 0.25%

Engine Lubrication System

Type of Oil Pump Gear
 Oil Filter Full Flow Spin-on, Cartridge
 Crankcase Oil Capacity 5.25 U.S. qts.
 (including oil filter capacity)

◆ COOLING SYSTEM

Type..... Pressurized Closed Recovery
 Water Pump..... Belt Driven
 Fan Speed..... 1980 rpm
 Fan Diameter..... 18.1 inches
 Fan Mode..... Pusher
 Air Flow (inlet air including alternator and
 combustion air) 2400 ft³/min.
 Coolant Capacity (3.0 U.S. gal.)
 Heat Rejection to Coolant (22/27kW) 99,000/105,000 Btu/h
 Maximum Operating Air Temp. on Radiator..... 60° C (150° F)
 Maximum Ambient Temperature 50° C (140° F)

◆ FUEL SYSTEM

Type of Fuel Natural Gas, Propane Vapor
 Carburetor..... Down Draft
 Secondary Fuel Regulator..... Standard
 Fuel Shut-off Solenoid..... Standard
 Operating Fuel Pressure 5 in. - 14 in. Water Column

Fuel Consumption - ft³/hr (Natural Gas/LPV)

	Exercise Cycle	25% Load	50% Load	75% Load	100% Load
22kW	42/16	100/40	190/75	255/101	316/125
27kW	42/16	108/43	197/78	287/114	359/143

◆ ELECTRICAL SYSTEM

Battery Charge Alternator 12V, 30 Amp
 Static Battery Charger 2.5 Amp
 Recommended Battery..... Group 26, 525CCA
 System Voltage 12 Volts

Voltage Regulator

Type..... Electronic
 Sensing Single-phase
 Regulation..... ± 1%
 Features..... V/F Adjustable, Adjustable
 Voltage and Gain LED Indicators

Power Adjustment for Ambient Conditions

Temperature Deration
 3% for every 10° C above °C (22/27kW) 25
 1.65% for every 10° above °F (22/27kW) 104/77
 Altitude Deration
 1% for every 100 m above m (22/27kW) 183
 3% for every 1000 ft. above ft. (22/27kW) 2500/600

Controller R-200C

◆ WEATHER AND MAINTENANCE KITS

To keep the generator running at its peak, the following kits are offered:

- Cold Weather Kit
 - ~ Recommended for climates with temperatures below 32° F.
- Extreme Cold Weather Kit
 - ~ Recommended Block Heater Kit for protection in temperatures below 32° F. This kit comes pre-installed on all industrial gaseous units.
- Scheduled Maintenance Kit
 - ~ Kit includes the recommended parts to maintain the generator. Refer to the Service Schedule for regular maintenance intervals.

For additional information, or to order any of these kits, please contact an Authorized Service Dealer or Customer Service Representative.

RECONFIGURING THE FUEL SYSTEM

NOTE:

All models are configured to run on natural gas from the factory.

Before the generator can be operated using a LP fuel source, the fuel system and control panel (refer to the installation drawing for location) must be reconfigured. The steps to reconfigure the generator from a natural gas (NG) to a liquidified petroleum (LP) fuel source are as follows:

◆ FUEL SYSTEM

1. Turn the main gas supply off and disconnect the battery.
2. Remove the carburetor fuel hose from the outlet port of the demand regulator (see Figure 6.1).
3. Disconnect the power wires from the fuel solenoid located on top of the regulator assembly by removing the screw on the front of the connector and pulling the connector forward, away from the solenoid body.
4. Loosen the spring clamp on the small fuel enrichment line and remove the hose from the hose barb.
5. Remove the black pipe assembly from the outlet port of the demand regulator. The solenoid assembly may need to be removed before performing this operation (Figure 6.1).
6. Remove the NG fuel jet (loosen counter clockwise) from the outlet port.
7. Remove the LP fuel jet (loosen counter clockwise) from the jet keeper port on the side of the regulator housing. Install this jet into the outlet port in the regulator casting.

NOTE:

The jet sizes are stamped on the individual jets. The larger jet size is used for running on NG.

8. Install the previously removed NG jet into the jet keeper port on the side of the regulator housing.
9. Install the previously removed black pipe onto the outlet port of the demand regulator. Use pipe sealant on the pipe threads.
10. Reverse steps 1-4 in this procedure to reactivate the demand regulator.
11. Follow the instructions in the Control Panel section.

— **⚠ DANGER ⚠** —

⚠ Serious injury or damage may occur if not configured properly. Please consult an Authorized Dealer with any questions.

Figure 6.1 — Reconfigure the Fuel System

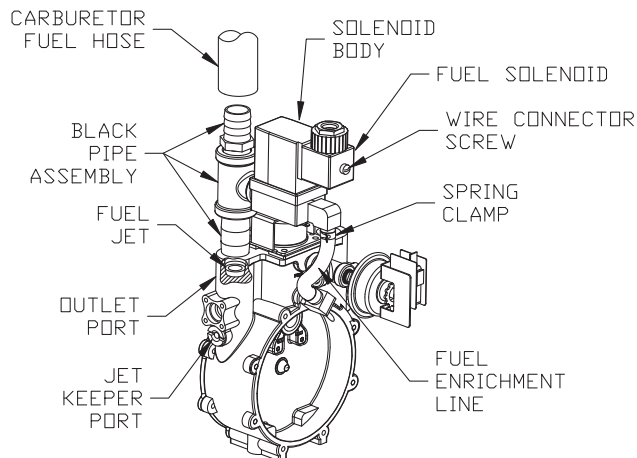

◆ CONTROL PANEL

The fuel select dipswitch is located in the control panel on the circuit board. Engine timing for Natural Gas (NG) Fuel is selected when dipswitch position 4 is set to "ON". Engine timing for LP Fuel is selected when this switch is set to "OFF". See the R-200C Control Panel manual for details.

— **⚠ CAUTION ⚠** —

⚠ Whenever the Generator's Fuel Regulator is converted from one Fuel type to the other, make sure to configure the Fuel Select Connector for the correct Fuel type.

ALTERNATOR AC LEAD CONNECTIONS

See "Voltage Codes". This Stationary Emergency Generator may be rated at any one of three voltages, either single-phase or three-phase. The electrical wires in the unit's AC connection (lower) panel should be installed according to the number of leads and the voltage/phase required for the application. If there are any questions regarding lead connection, refer to the wiring diagrams at the back of this manual.

Voltage codes apply to the type of stator assembly installed on a particular generator.

◆ FOUR-LEAD, SINGLE-PHASE STATOR

Four-lead alternators (see Figure 7.1) are designed to supply electrical loads with voltage code "A" (240V, 1-phase, 60 Hz). Electrical power is produced in the stator power windings. These windings were connected at the factory to the main circuit breaker as shown in Figure 7.1.

The rated voltage between each circuit breaker terminal is 240V. The rated voltage between each circuit breaker terminal and the neutral point 00 is 120V.

Figure 7.1 — Four-lead, Single-phase Stator

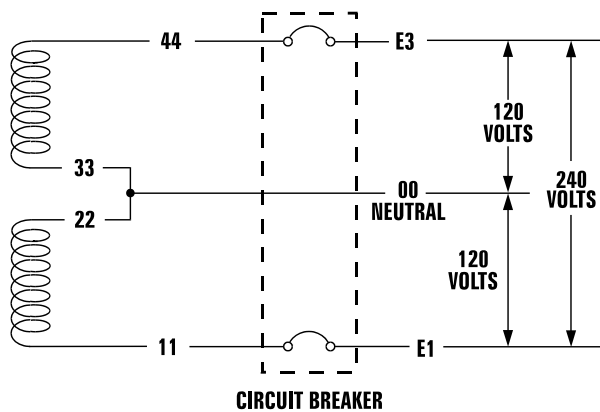

ALTERNATOR POWER WINDING CONNECTIONS

◆ 3-PHASE ALTERNATORS

The Stationary Emergency Generator is designed to supply 3-phase electrical loads. Electric power is produced in the alternator power windings. These windings were connected at the factory to the main circuit breaker with a "Y" configuration as shown in Figures 7.2 and 7.3.

The rated voltage between circuit breaker terminals E1-E2, E1-E3 and E2-E3 is either 480V or 208V depending on the model.

The rated voltage between each circuit breaker terminal and the neutral point 00 is either 277V or 120V depending on the model.

Figure 7.2 — Stator Power Winding Connections - 3-phase, 277/480V (6 Lead)

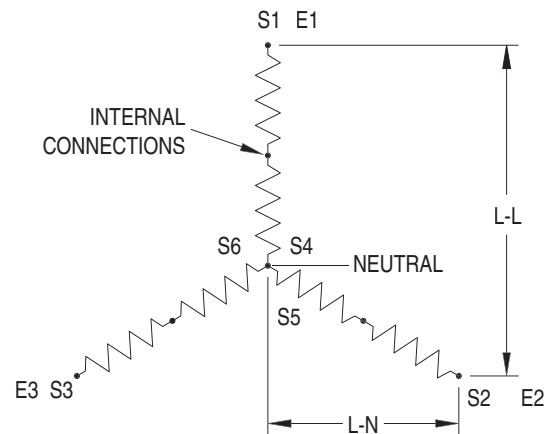
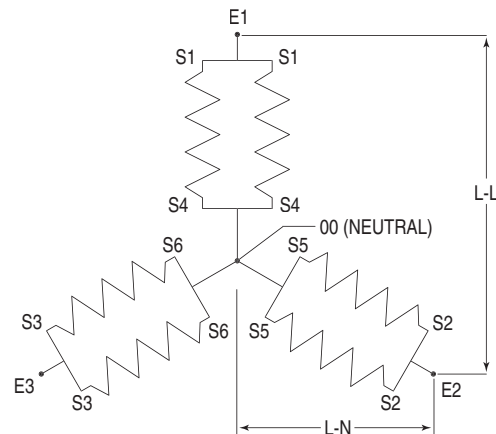

Figure 7.3 — Stator Power Winding Connections - 3-phase, 120/208V (6 Lead)





INSTALLATION

Refer to the separate "Installation Guide" supplied with the unit.

For safety reasons, the manufacturer recommends that this equipment be installed, serviced and repaired by a Service Dealer or other competent, qualified electrician or installation technician who is familiar with applicable codes, standards and regulations. The operator also must comply with all such codes, standards and regulations.

PREPARATION BEFORE START-UP

The instructions in this section assume that the Stationary Emergency Generator has been properly installed, serviced, tested, adjusted and otherwise prepared for use by a competent, qualified installation contractor. Be sure to read the "Safety Rules", as well as all other safety information in this manual, before attempting to operate this (and related) equipment.

Before starting the generator for the first time, the installer must complete the following procedures. For follow-up maintenance information and/or service intervals, please refer to the "Maintenance" section and the "Service Schedule".

◆ TRANSFER SWITCH

If this generator is used to supply power to any electrical system normally powered by an electric utility, the National Electrical Code requires that a transfer switch be installed. The transfer switch prevents electrical backfeed between two different electrical systems. (For additional information, see the applicable transfer switch manual for this unit.) The transfer switch, as well as the generator and other electrical components, must be properly located and mounted in strict compliance with applicable codes, standards and regulations.

◆ FUEL SYSTEM

Make sure the fuel supply system to the generator (a) delivers the correct fuel at the correct pressure and (b) is properly purged and leak tested according to code. No fuel leakage is permitted. See "Specifications" for more information.

◆ GENERATOR SET LUBRICATION

Check the engine crankcase oil level before operating and add oil to the proper level – the dipstick "FULL" mark. Never operate the engine with the oil level below the dipstick "ADD" mark. See "Specifications" and "Engine Oil Recommendations".

Check the oil level in the generator gearbox (if so equipped) prior to initial use and at the intervals indicated by the "Service Schedule." The recommended oil is SAE 90 gear lubricant.

NOTE:

This engine is shipped from the manufacturer with "break-in" oil. This oil should be changed after 30 hours of operation.

◆ PRIOR TO INITIAL START-UP



⚠ Prior to initially starting the generator, it must be properly prepared for use. Any attempt to crank or start the engine before it has been properly serviced with the recommended types and quantities of engine fluids (oil, coolant, fuel, etc.) may result in an engine failure.

◆ ENGINE COOLANT

Have the engine cooling system properly filled with the recommended coolant mixture. Check the system for leaks and other problems. See "Specifications" and "Coolant" sections.

◆ BELT TENSION

Check the engine-fan belt tension and condition prior to placing the unit into service and at recommended intervals. Belt tension is correct when a force of approximately 22 pounds (10 kg), applied midway between pulleys, deflects the belt about 3/8- to 5/8-inch (10 to 16 mm).

◆ ELECTRICAL SYSTEM

Make sure the generator is properly connected to an approved earth ground.

Make sure the generator battery is fully charged, properly installed and interconnected, and ready for use.

NOTE:

Battery charger must be connected to 120 VAC, 15 amp circuit to operate.

Check to ensure that there are no loose electrical connections. Restrain any loose wires to keep them clear of any moving generator set components.

INITIAL INSPECTION FOR GENSET STARTUP

Inspect for the following.

- Freight Damage.
- Manuals present.
- Fluid Levels (Oil, coolant, battery, Gear Drive).
- Correct fuel piping.
- Correct muffler installation for external applications (open units only).
- Adequate air flow, clearances and ventilation per installation drawings and applicable codes.
- Correct AC and DC wire size, connections and grounding. Control and communication wiring to/from the transfer switch must be run in a separate conduit from the AC power leads.
- **Battery charger connection to 120 VAC.**
- Unit secured to pad.



START-UP CHECKLIST



WARNING

⚠ Before working on the Stationary Emergency Generator, ensure the following:

- The AUTO/OFF/MANUAL switch is in the OFF position.
- The 120VAC supply to the battery charger is switched OFF.

◆ PREPARATION FOR START-UP

- Ensure that the 120VAC circuit breaker to the battery charger is open.
- Remove the fuse from the the control panel. Open the front door of the control box and remove the 15 Amp ATO fuse in the lower left-hand corner of the control box.
- Connect the battery cables to the battery. Attach negative battery cable last.
- Close the 120VAC circuit breaker to the battery charger.
- Measure the voltage at the battery before and after the charger is turned on.
- Verify all AC electrical connections are tight at the circuit breaker and transfer switch.
- Visually inspect entire area looking for loose paper, plastic wrappings, leaves, etc.
- Check all hoses clamps fittings for leaks or damage.
- Check all electrical plugs throughout the generator. Ensure each plug is seated correctly and fully inserted into its receptacle.
- Verify the AUTO/OFF/MANUAL switch is in OFF position.
- Open the valve to the engine fuel line.
- Bleed the fuel system of air. (necessary for long fuel lines).
- Open the generator main line circuit breaker.
- Connect a manometer to the gas line and record the static pressure. It must be as listed in the Specifications.
- Insert the fuse into the control panel.
- Move the AUTO/OFF/MANUAL switch to the manual position. The engine should now crank and start.
- Check voltage at the generator terminals.
- For 3-phase units, check phase rotation at the transfer switch terminals. The generator phase rotation must match the utility phase rotation.
- Check for coolant, fuel, oil, and exhaust leaks.
- Close the generators main line circuit breaker.
- Turn the generator set off.
- Connect the UTILITY supply to the transfer switch.
- Set the AUTO/OFF/MANUAL switch to AUTO.
- Disconnect utility power before the transfer switch.
 - Engine should start, transfer to load.
 - Run at least 15 minutes on generator power. Make certain all 3-phase loads are functioning correctly (correct phase rotation).
- Reconnect Utility power
 - Transfer switch will transfer back to Utility and engine will shut down within the given time parameters set up for the specific transfer switch and controller.
- Install all covers, access plates and door panels.
- Put the Owners Manual in a safe and accessible place.
- Make certain the AUTO/OFF/MANUAL switch is in the AUTO position.

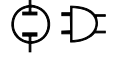
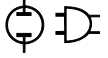

STATIONARY EMERGENCY GENERATOR CONTROL AND OPERATION

Refer to the appropriate control panel operator's manual for this unit.

OPERATING UNIT WITH MANUAL TRANSFER SWITCH

If the Stationary Emergency Generator was installed in conjunction with a transfer switch capable of manual operation only, the following procedure applies. A manually operated transfer switch is one that will not provide automatic start-up and does not include an intelligence circuit.

◆ ENGINE START-UP AND TRANSFER

For additional information, refer to the applicable control panel manual for this unit, as well as any literature pertaining to the specific transfer switch.



⚠ The Maintenance Disconnect Switch and the AUTO/OFF/MANUAL switches (if so equipped) must be set properly, or the generator will crank and start as soon as the utility power to the transfer switch is turned off. Refer to applicable control panel and transfer switch manuals for more information.

⚠ Do not proceed until certain that utility source voltage is available to the transfer switch and the transfer switch main contacts are set to UTILITY.

⚠ Do not attempt manual operation until all power supplies to the transfer switch have been positively turned off, or extremely dangerous - possibly lethal - electrical shock will result.

⚠ Transfer switch enclosure doors should be kept closed and locked. Only authorized personnel should be allowed access to the transfer switch interior. Extremely high and dangerous voltages are present in the transfer switch.

In order to transfer load from the utility source to the generator, follow these directions:

- Turn OFF or disconnect the utility power circuit to the transfer switch, using the means provided (such as the utility source main line circuit breaker).
- Set the transfer handle to its UTILITY (NORMAL) position with load circuits connected to the utility power supply.
- Set the generator's main line circuit breaker to its OFF (or OPEN) position.
- Start the generator.



⚠ Do not crank the engine continuously for longer than 30 seconds, or the heat may damage the starter motor.

- Let engine stabilize and warm up.
- Check all applicable instrument and gauge readings. When certain that all readings are correct, move the transfer switch manual handle to the STANDBY (or EMERGENCY STANDBY) position, i.e., load circuits supplied by the generator.
- Set the generator's main line circuit breaker to its ON (or CLOSED) position.
- Load circuits are now powered by the generator.

◆ RETRANSFER AND SHUTDOWN

For additional information, refer to the applicable control panel manual for this unit, as well as any literature pertaining to the specific transfer switch.

To transfer the load back to the utility power source and shut down the generator, follow these directions:

- Set the generator's main line circuit breaker to its OFF (or OPEN) position.
- Manually move the transfer switch handle to its UTILITY (NORMAL) position, i.e., load circuits connected to the utility.
- Turn ON the utility power supply to the transfer switch, using the means provided (such as the utility power source main line circuit breaker).
- Let the generator run at no-load for a few minutes to stabilize internal temperatures.
- Shut down the generator.

OPERATING UNIT WITH AUTOMATIC TRANSFER SWITCH

If the Stationary Emergency Generator has been installed with an automatic transfer switch, the engine may be started and stopped automatically or manually.

NOTE:

Refer to the applicable manual for your transfer switch and to "Transfer Switch Start Signal Connections". In addition, please note the dangers under "Engine Start-up and Transfer."



MAINTENANCE PERFORMED BY SERVICE DEALERS/CONTRACTORS

⚠ WARNING ⚠

⚠ Before working on the Stationary Emergency Generator, ensure the following:

- The AUTO/OFF/MANUAL switch is in the OFF position.
- The 15A fuse has been removed from the control box.
- The 120VAC supply to the battery charger is switched OFF.
- The negative battery cable has been removed.

◆ EVERY THREE MONTHS

1. Check battery condition.
2. Inspect and test fuel system.
3. Check transfer switch.
4. Inspect exhaust system.
5. Check engine ignition system.
6. Check fan belts.

◆ ONCE EVERY SIX MONTHS

1. Test Engine Safety Devices (low oil pressure, low coolant level, high coolant temperature).

◆ ONCE ANNUALLY

1. Test engine governor; adjust or repair, if needed.
2. Clean, inspect generator.
3. Flush cooling system.
4. Clean/re-gap spark plugs or replace as necessary.

◆ FIRST 30 OPERATING HOURS

1. Change engine "break-in" oil and filter.

◆ FIRST 100 OPERATING HOURS

1. Change engine oil and oil filter. After initial change, service engine oil and filter at 100 operating hours or six months, whichever comes first.
2. Retorque intake and exhaust manifold.

◆ EVERY 500 OPERATING HOURS

1. Service air filter.
2. Check starter.
3. Check engine DC alternator.

COOLING SYSTEM

Air intake and outlet openings in the generator compartment must be open and unobstructed for continued proper operation. This includes such obstructions as high grass, weeds, brush, leaves and snow.

Without sufficient cooling and ventilating air flow, the engine/generator quickly overheats, which causes it to shut down. (See the installation diagram.)

⚠ WARNING ⚠

⚠ The exhaust system parts from this product get extremely hot and remains hot after shutdown. High grass, weeds, brush, leaves, etc. must remain clear of the exhaust. Such materials may ignite and burn from the heat of the exhaust system.

OVERLOAD PROTECTION FOR ENGINE DC ELECTRICAL SYSTEM

Engine cranking, start up and running are controlled by a solid state Engine Controller circuit board. Battery voltage is delivered to that circuit board via a 15 amp fuse. These overcurrent protection devices will open if the circuit is overloaded.

⚠ CAUTION ⚠

⚠ If a circuit breaker opens or a fuse element melts, find the cause of the overload before resetting the circuit breaker or replacing the fuse.

CHECKING FLUID LEVELS

◆ CHECK ENGINE OIL

Check engine crankcase oil level (Figure 10.1) at least every 20 hours of operation, or prior to use.

Figure 10.1 - Oil Dipstick and Oil Fill Cap

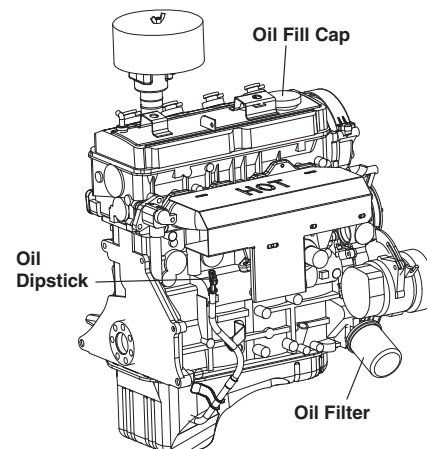



- Remove oil dipstick and wipe dry with a clean, lint-free cloth.
- Install oil dipstick, then remove again.
- Oil should be between FULL and ADD marks.
- If oil level is below the dipstick ADD mark, remove oil fill cap. Add the recommended oil to bring oil level up to the FULL mark. **DO NOT FILL ABOVE THE "FULL" MARK.** See "Engine Oil Recommendations" for recommended oils.

◆ BATTERY FLUID

Check battery electrolyte fluid based on the Maintenance Schedule. Fluid should cover separators in all battery cells. If fluid level is low, add distilled water to cover tops of separators. **DO NOT USE TAP WATER IN BATTERY.**

◆ ENGINE COOLANT

Check coolant level in coolant recovery bottle. See the Specifications section.

- Add recommended coolant mixture as necessary.
- Periodically remove radiator pressure cap (only when engine has cooled down) to make sure the coolant recovery system is functioning properly. Coolant should be at bottom of radiator filler neck. If coolant level is low, inspect gasket in radiator pressure cap. Replace cap, if necessary. To have pressure cap tested, contact a Service Facility. Inspect cooling system and coolant recovery system for leaks.

MAINTENANCE OWNER/ OPERATOR CAN PERFORM



⚠ Before working on the generator, ensure the following:

- The AUTO/OFF/MANUAL switch is in the OFF position.
- The 15A fuse has been removed from the control box.
- The 120VAC supply to the battery charger is switched OFF.
- The negative battery cable has been removed.

◆ CHECK ENGINE OIL LEVEL

Refer to "Checking Fluid Levels".

◆ CHECK BATTERY

- See "Checking Fluid Levels".
- Check battery cables for condition, tightness, corrosion or damage. Clean, tighten or replace as necessary.

◆ EXERCISE SYSTEM

Start the Stationary Emergency Generator engine at least once every seven days and let it run at least 20 minutes. For more detailed exercise information, see the respective sections in the Control Panel Technical Manual that is supplied with the unit.

◆ INSPECT COOLING SYSTEM

- Inspect engine cooling system. See "Maintenance Schedule".
- Check hoses for damage, deterioration, leaks, etc. Correct any discrepancies found.
- Check hose clamps for tightness.

◆ CHECK ENGINE COOLANT LEVEL

See the "Checking Fluid Levels" section.

◆ PERFORM VISUAL INSPECTION

Complete a thorough visual inspection of the entire engine-generator monthly. Look for obvious damage, loose, missing or corroded nuts, bolts and other fasteners. Look for fuel, oil or coolant leaks.

◆ INSPECT EXHAUST SYSTEM

Inspect the exhaust system at least once every three months. Check all exhaust system pipes, mufflers, clamps, etc. for condition, tightness, leaks, security, damage.

◆ CHECK FAN BELT

- Inspect fan belts every three months. Replace any damaged, deteriorated, worn or otherwise defective belt.
- Check fan belt tension. Thumb pressure, exerted midway between pulleys, should deflect about 3/8 to 5/8 of an inch. Adjust belt tension as required.
- Check fan belt alignment (see Figure 10.2).

Figure 10.2 – Fan Belt

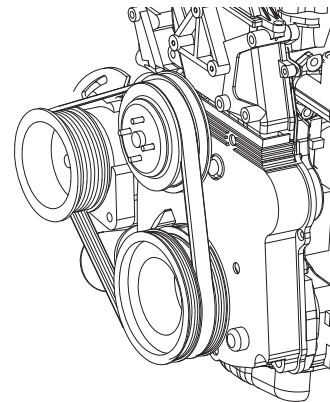

◆ INSPECT ENGINE GOVERNOR

Visually inspect electronic governor.



⚠ Do not attempt to adjust the governor. Only qualified service facilities should adjust the governor. Excessively high operating speeds are dangerous and increase the risk of personal injury. Low speeds impose a heavy load on the engine when adequate engine power is not



available and may shorten engine life. Correct rated frequency and voltage are supplied only at the proper governed speed. Some connected electrical load devices may be damaged by incorrect frequency and/or voltage. Only qualified service technicians should adjust the governed speed.

◆ CHANGING ENGINE OIL



⚠ **Hot oil may cause burns. Allow engine to cool before draining oil. Avoid prolonged or repeated skin exposure with used oil. Thoroughly wash exposed areas with soap.**

Refer to maintenance performed by service facilities for engine oil and filter change frequencies.

Drain the oil while the engine is still warm from running. This means warm up the engine, shut it down and drain immediately as follows:

1. Remove the drain hose from its retaining clip or cut the zip-tie securing the oil drain hose.
2. Loosen and remove OIL DRAIN HOSE CAP. Drain oil completely into suitable container.
3. When all oil has drained, install and tighten OIL DRAIN HOSE CAP and secure drain hose with a new zip-tie, or place the hose in its retaining clip.
4. Turn OIL FILTER (Figure 10.3) counterclockwise and remove. Properly dispose of old filter.

Figure 10.3 – Oil Filter

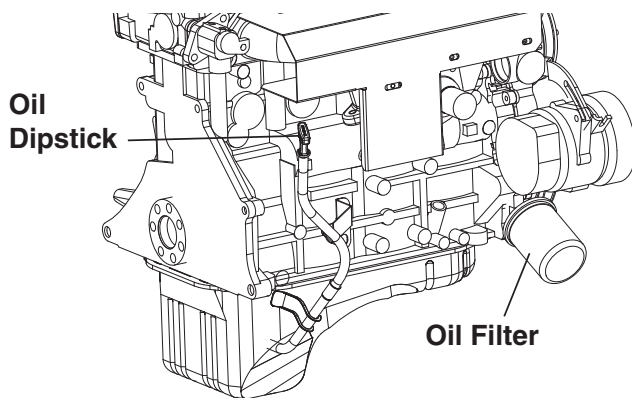

5. Apply light coating of new engine oil to seal of new oil filter. -Install FILTER and tighten by hand only. DO NOT OVER TIGHTEN.
6. Remove OIL FILL CAP and add recommended oil. Crankcase oil capacity is listed in the "Specifications" section.



⚠ **After refilling the crankcase with oil, always check oil level on dipstick. NEVER OPERATE ENGINE WITH OIL BELOW THE DIPSTICK "ADD" MARK.**

7. Start engine and check for oil leaks.
8. Shut OFF engine and wait 10 minutes for the oil to settle down into the oil pan. Recheck oil level on dipstick. DO NOT fill above the dipstick "FULL" mark.
9. Dispose of used oil at a proper collection center.

◆ CHANGING THE ENGINE AIR FILTER

To replace the engine air filter, remove the air filter cover and replace the air filter making sure it is positioned properly before reattaching the cover (Figure 10.4).

See the "Service Schedule," for air filter maintenance.

Figure 10.4 – Engine Air Filter

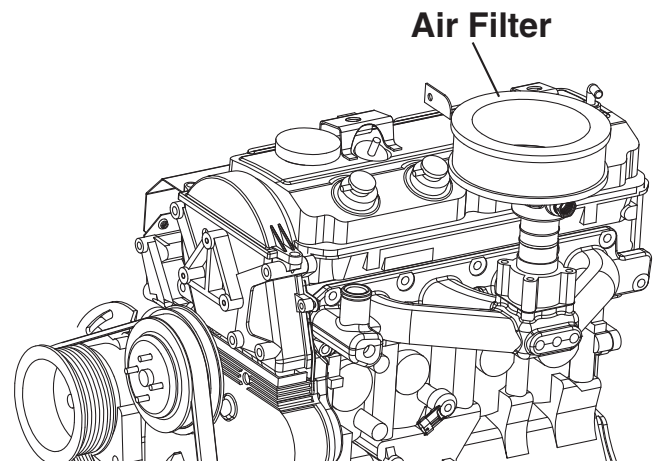

◆ SPARK PLUGS

Reset the spark plug gap or replace the spark plugs as necessary (Figure 10.5).

1. Clean the area around the base of the spark plugs to keep dirt and debris out of the engine. Clean by scraping or washing using a wire brush and commercial solvent. Do not blast the spark plugs to clean.
2. Remove the spark plugs and check the condition. Replace the spark plugs if worn or if reuse is questionable. See the "Service Schedule" section for recommended inspection.
3. Check the spark plug gap using a wire feeler gauge. Adjust the gap to 1.07-1.17 mm (0.042-0.046 inch) by carefully bending the ground electrode (Figure 10.5).



Figure 10.5 – Setting the Spark Plug Gap

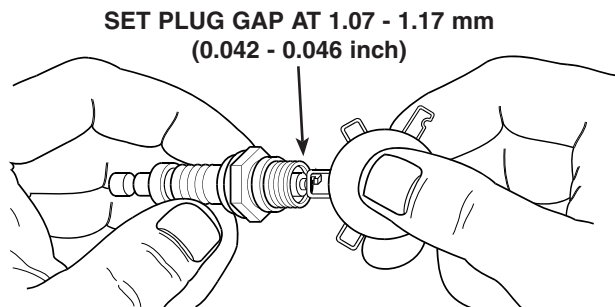

◆ COOLANT CHANGE

Every year, have a service facility drain, flush and refill the cooling system. See "Specifications" for cooling system recommendations.

MISCELLANEOUS MAINTENANCE

◆ CLEANING THE STATIONARY EMERGENCY GENERATOR

Keep the generator as clean and as dry as possible. Dirt and moisture that accumulates on internal generator windings have an adverse effect on insulation resistance.

Periodically clean generator exterior surfaces. A soft brush may be used to loosen caked on dirt. Use a vacuum system or dry, low pressure air to remove any accumulations of dirt. The generator is housed inside an all-weather enclosure, clean the enclosure with a soft, damp cloth or sponge and water.

Once each year have the generator cleaned and inspected by a Service Dealer. That dealer will use dry, low pressure air to clean internal windings. Parts inside the control console should be cleaned and inspected at this time as well.

Finally, have the insulation resistance of stator and rotor windings checked. If insulation resistances are excessively low, the generator may require drying.

◆ BATTERY

All lead-acid storage batteries discharge when not in use. Refer to specific instructions and warnings that accompany the battery. If such information is not available, observe the following precautions when handling a battery:

- DO NOT use jumper cables and a booster battery to crank or start the generator engine.
- DO NOT recharge a weak battery while it is installed in the generator. Remove battery from generator and recharge in a well-ventilated area, away from fuel vapors, sparks, heat or flames.
- Battery electrolyte fluid is an extremely caustic sulfuric solution that can cause severe burns. DO NOT permit fluid to contact eyes, skin, clothing, painted surfaces, wiring insulation, etc. If any battery fluid is spilled, flush the affected area with clear water immediately.

- Always wear safety glasses, rubber apron and gloves when handling a battery.
- Batteries give off explosive hydrogen gas while charging. The gas can form an explosive mixture around the battery for several hours after charging. Any spark, heat or flames can ignite the gas and cause an explosion which can shatter the battery, causing blindness or other serious injury.

◆ BATTERY MAINTENANCE

The battery should be inspected per the "Scheduled Maintenance" section. The following procedure should be followed for inspection:

1. Inspect the battery posts and cables for tightness and corrosion. Tighten and clean as necessary.
2. Check the battery fluid level of unsealed batteries and, if necessary, fill with DISTILLED WATER ONLY. DO NOT USE TAP WATER IN BATTERIES.
3. Have the state of charge and condition checked. This should be done with an automotive-type battery hydrometer.

—▲ DANGER ▲—

▲ Storage batteries give off explosive hydrogen gas. This gas can form an explosive mixture around the battery for several hours after charging. The slightest spark can ignite the gas and cause an explosion. Such an explosion can shatter the battery and cause blindness or other injury. Any area that houses a storage battery must be properly ventilated. Do not allow smoking, open flame, sparks or any spark producing tools or equipment near the battery.

▲ Battery electrolyte fluid is an extremely corrosive sulfuric acid solution that can cause severe burns. Do not permit fluid to contact eyes, skin, clothing, painted surfaces, etc. Wear protective goggles, protective clothing and gloves when handling a battery. If fluid is spilled, flush the affected area immediately with clear water.

▲ Do not use any jumper cables or booster battery to crank and start the generator engine. If the battery has completely discharged, remove it from the generator for recharging.

—▲ WARNING ▲—

▲ Be sure the AUTO/OFF/MANUAL switch is set to the OFF position, before connecting the battery cables. If the switch is set to AUTO or MANUAL, the generator can crank and start as soon as the battery cables are connected.

▲ Be sure the 120VAC power supply to the battery is turned OFF, or sparking may occur at the battery posts as the cables are attached and cause an explosion.



◆ BATTERY REPLACEMENT

NOTE:

Unit DOES NOT include battery.

When supplying or replacing the battery, the recommended number and type of battery is listed in the Specifications Section.

NOTE:

The BCI number should be located directly on the battery.

REPAIR PARTS

The later portion of this manual consists of exploded views, parts lists and electrical data pertaining to this generator set. The parts list consists of: (a) an Item Number, (b) a Part Number, (c) Quantity required, and (d) a Description of the part. The Item Number corresponds to an identical number on the exploded view drawing.



Stationary Emergency Generator Service Schedule



SERVICE SCHEDULE

22 KW - 150 KW GASEOUS STATIONARY EMERGENCY GENERATOR

The following is a recommended maintenance schedule for Gaseous Stationary Emergency Generator sets from 22kW to 150 kW in size. The established intervals in the schedule are the maximum recommended when the unit is used in an average service application. They will need to be decreased (performed more frequently) if the unit is used in a severe application. Use calendar time, from the previous maintenance interval to determine the next required maintenance interval.

Service Maintenance Interval Information:

The various service maintenance intervals are designated by interval numbers as follows:

- 1 An early inspection of the generator set to insure it is ready to operate when required and to identify any potential problem areas.



This inspection may be performed by the end user providing the following safety steps are taken to prevent the engine from starting automatically without warning:

To prevent injury, perform the following steps in the order indicated before starting any maintenance:

- Disable the generator set from starting and/or connecting to the load by setting the control panel Auto/Off/Manual switch to the "OFF" position.
- Remove the 15 amp control panel fuse.
- Turn off the battery charger.*
- Remove the negative battery cable.



** The battery charger must be turned off BEFORE removing the battery cable to prevent an over current condition from burning out sensitive control panel components and circuits.*

Following all maintenance, reverse these steps to insure the unit is returned to standby setup for normal operation when required.

- 2 A wear-in service inspection of the generator set to insure it is ready to operate and carry the load when required, and to identify any potential problem areas.

*Performed **ONLY ONCE** following the first three months or the first 30 hours of operation after purchase of the unit.*

This inspection contains some maintenance tasks which require special tools, equipment, and/or knowledge to accomplish and should be performed only by a Service Dealer.

- 3 An operational inspection of the generator set to insure it is ready to operate and carry the load when required, and to identify any potential problem areas.

Performed semi-annually or following each 50 hours of operation of the unit.

This inspection contains some maintenance tasks which require special tools, equipment, and/or knowledge to accomplish and should be performed only by a Service Dealer.

- 4 A mid-level inspection of the generator set to insure it is ready to operate and carry the load when required, and to identify any potential problem areas.

Performed annually or following each 100 hours of operation of the unit.

This inspection contains some maintenance tasks which require special tools, equipment, and/or knowledge to accomplish and should be performed only by a Service Dealer.

- 5 A comprehensive inspection of the generator set to insure it is properly serviced and ready to operate and carry the load when required, and to identify any potential problem areas.

Performed annually or following each 250 hours of operation of the unit.

This inspection contains some maintenance tasks which require special tools, equipment, and/or knowledge to accomplish and should be performed only by a Service Dealer.



Stationary Emergency Generator Service Schedule



Maintenance Tasks	Level 1	Task Comp. (Date-Initials)	Level 2	Task Comp. (Date-Initials)	Level 3	Task Comp. (Date-Initials)	Level 4	Task Comp. (Date-Initials)	Level 5	Task Comp. (Date-Initials)
	Recommended to be done monthly/ 10 hrs.		Required to be done 3 months/ Break-in 30 hrs.		Required to be done Semi-annually/ 50 hrs.		Required to be done Annually/ 100 hrs.		Required to be done Bi-annually/ 250 hrs.	
1. Disable the unit from operating per the first page warning.	○		○		○		○		○	
2. Check the engine oil level. Adjust as necessary.	○		○		○		○		○	
3. Check the engine coolant level. Adjust as necessary.	○		○		○		○		○	
4. Check the engine coolant thermal protection level. Correct as necessary.							○		○	
5. Check the natural gas delivery system for leaks and correct pressure on gas engine driven units. Tighten connections as necessary.	○		○		○		○		○	
6. Check the air inlets and outlets of the enclosure and radiator for debris. Clean as necessary.	○		○		○		○		○	
7. Check the battery electrolyte level and specific gravity if accessible. Adjust as necessary.	○		○		○		○		○	
8. Check the battery posts, cables, and charger for loose connections corrosion, and proper operation. Correct as necessary.	○		○		○		○		○	
9. Check the unit wiring for loose connections, corrosion, and damage. Correct as necessary.	○		○		○		○		○	



Stationary Emergency Generator Service Schedule



Maintenance Tasks	Level 1	Task Comp. (Date-Initials)	Level 2	Task Comp. (Date-Initials)	Level 3	Task Comp. (Date-Initials)	Level 4	Task Comp. (Date-Initials)	Level 5	Task Comp. (Date-Initials)
	Recommended to be done monthly/ 10 hrs.		Required to be done 3 months/ Break-in 30 hrs.		Required to be done Semi-annually/ 50 hrs.		Required to be done Annually/ 100 hrs.		Required to be done Bi-annually/ 250 hrs.	
10. Check the engine accessory drive belts and fan coupling device if equipped for correct tension, wear, weather cracking, and damage. Replace as necessary.			○				○		○	
11. Check the engine valve clearance/ lash. Adjust as necessary.**							○		○	
12. Visually inspect the unit looking for leaks, wear or damage, loose connections or components, and corrosion. Correct as necessary.							○		○	
13. Test the engine and transfer switch safety devices. Correct and/or adjust as necessary.	○		○		○		○		○	
14. Initiate an automatic start and transfer of the unit to site load and exercise it for at least 1 hour looking for leaks, loose connections or components, and abnormal operating conditions. Correct as necessary.							○		○	
15. Replace the engine accessory drive belts.									○	
16. Check gearbox oil level (if equipped).	○		○		○		○		○	
17. Change gearbox oil (if equipped).									○	

** Not required for engines equipped with hydraulic lifters. See the "Specification" section for lifter type.



Stationary Emergency Generator Service Schedule



Maintenance Tasks	Level 1	Task Comp. (Date-Initials)	Level 2	Task Comp. (Date-Initials)	Level 3	Task Comp. (Date-Initials)	Level 4	Task Comp. (Date-Initials)	Level 5	Task Comp. (Date-Initials)
	Recommended to be done monthly/ 10 hrs.		Required to be done 3 months/ Break-in 30 hrs.		Required to be done Semi-annually/ 50 hrs.		Required to be done Annually/ 100 hrs.		Required to be done Bi-annually/ 250 hrs.	
18. Start and exercise the unit at full rated load (use a load bank if the site load is not enough) for at least 2 hours looking for leaks, loose connections or components, and abnormal operating conditions. Correct as necessary.									●	
19. Perform an engine oil analysis (send a sample to a lab for results). Change the engine oil and filters if the analysis results indicate this is required.							●			
20. Change the engine oil.			●				●		●	
21. Replace the engine oil filter(s).			●				●		●	
22. Replace engine spark plugs. Clean and re-gap or replace as necessary.							●			
23. Replace the engine air filter(s).									●	
24. Perform a 5 minute no-load operational run of the unit looking for any post service problems.			●						●	
25. Return the unit to standby setup for operation when required.	●		●		●		●		●	



TROUBLESHOOTING GUIDE

PROBLEM	CAUSE	CORRECTION
Engine won't crank.	<ol style="list-style-type: none"> 15 amp fuse blown. Loose or corroded or defective battery cables. Defective starter contactor. Defective starter motor. Dead or Defective Battery. 5 amp fuse blown. 	<ol style="list-style-type: none"> Replace fuse. Tighten, clean or replace battery cables as necessary. Replace contactor.* Replace starter motor.* Remove, change or replace battery. Replace fuse.*
Engine cranks but won't start	<ol style="list-style-type: none"> Out of fuel. Fuel solenoid (FS) is defective Open Wire #14A from Engine Control circuit board. Spark plugs defective. Door on tank not closed. 	<ol style="list-style-type: none"> Replenish fuel. Replace solenoid.* Reconnect wire. Clean, regap or replace plugs. Close door on tank.
Engine starts hard, runs rough.	<ol style="list-style-type: none"> Flame arrestor (air cleaner) plugged or damaged. Plugged fuel line. Defective spark plugs. Fuel pressure incorrect. 	<ol style="list-style-type: none"> Clean or replace as needed. Unclog fuel line. Clean, regap or replace plugs. Confirm fuel pressure to regulator is as recommended in SPECIFICATIONS.
Engine starts then shuts down.	<ol style="list-style-type: none"> Engine oil level is low. Engine is overheated. Defective Low Oil Pressure Switch Defective Coolant Temperature Switch Defective Control Module circuit board. Coolant Level is Low. Defective Low Coolant Level Switch 	<ol style="list-style-type: none"> Check oil and add oil as needed. Check cooling system for leaks. Replace switch.* Replace switch.* Replace board.* Repair leak - Add coolant. Replace Switch.*
AUTO/OFF/MANUAL Switch at OFF, engine continues to run	<ol style="list-style-type: none"> Defective AUTO/OFF/MANUAL switch Open/disconnected wire #15A between AUTO/OFF/MANUAL switch and Control Module circuit board. Defective Control Module circuit board 	<ol style="list-style-type: none"> Replace switch.* Reconnect/close wire. Replace board.*
No AC output from generator.	<ol style="list-style-type: none"> Check main line circuit breaker. Check circuit breaker & fuses. Transfer switch set to NORMAL position Generator internal failure. Thermal circuit breaker open. 	<ol style="list-style-type: none"> Reset to ON or CLOSED. Reset and replace, if necessary. Set to GENERATOR position. * Auto-reset - Wait 5 min. and attempt restart.

***Contact the nearest Dealer for assistance.**



United States Environmental Protection Agency Warranty Statement Warranty Rights, Obligations and Coverage

The United States Environmental Protection Agency (EPA) and Generac Power Systems, Inc. (Generac), are pleased to explain the Emission Control System Warranty on your new stationary emergency engine. If during the warranty period, any emission control system or component on your engine is found defective in materials or workmanship Generac will repair your engine at no cost to you for diagnosis, replacement parts and labor provided it be done by an Authorized Warranty Service Facility. Your emission control system may include parts such as the fuel metering, ignition, and exhaust systems and other related emission related components listed below. Generac will warrant the emissions control systems on your 2009 and later model year engines provided there has been no abuse, neglect, unapproved modification or improper maintenance of your engine. For engines less than 130 HP the warranty period is two years from the date of sale to the ultimate purchaser. For engines greater than or equal to 130 HP the warranty period is three year from the date of the engine being placed into service.

Purchaser's/Owner's Warranty Responsibilities

As the engine purchaser/owner you are responsible for the following. 1.) The engine must be installed and configured in accordance to the installation specifications. 2.) The completion of all maintenance requirements listed in your Owner's Manual. 3.) Any engine setting adjustment must be done in accordance and consistent with the instructions in the Owner's Manual. 4.) Any emission control system or component must be maintained and operated appropriately in order to ensure proper operation of the engine and control system to minimize emissions at all times.

Generac may deny any, or all Emission Control System Warranty coverage or responsibility of the engine, or an emission control system or component on your engine thereof, if it has failed due to abuse, neglect, unapproved modification or improper maintenance, or the use of counterfeit and/or 'gray market' parts not made, supplied or approved by Generac. Warranty service/scheduled maintenance can be arranged by contacting your selling dealer or an Authorized Warranty Service dealer. The purchaser/owner shall be responsible for any expenses or other charges incurred for service calls and/or transportation of the product to/from the inspection or repair facilities. The purchaser/owner shall be responsible for any and/or all damages or losses incurred while the engine is being transported/shipped for inspection or warranty repairs.

Emission Related Parts Include the Following (if so equipped)

- | | |
|--|---|
| <ul style="list-style-type: none"> 1) Fuel Metering System 1.1) Gasoline Carburetor assembly and internal components <ul style="list-style-type: none"> a) Fuel filter, b) Carburetor, c) Fuel Pump 1.2) Carburetion assembly and its components <ul style="list-style-type: none"> a) Fuel controller, b) Carburetor and its gaskets, c) Mixer and it gaskets, d) Primary gas regulator e) Liquid vaporizer 1.3) Fuel Regulator 2) Air Induction System including <ul style="list-style-type: none"> a) Intake pipe/manifold, b) Air cleaner | <ul style="list-style-type: none"> 3) Ignition System including <ul style="list-style-type: none"> a) Spark plug, b) Ignition module, c) ignition coil, d) Spark plug wirers 4) Exhaust system <ul style="list-style-type: none"> a) Catalyst assembly, b) Exhaust manifold, c) Muffler, d) Exhaust pipe, e) Muffler gasket 5) Crankcase Breather Assembly including <ul style="list-style-type: none"> a) Breather connection tube, b) PCV valve 6) Oxygen Sensor 7) Diagnostic Emission-Control System |
|--|---|



United States Environmental Protection Agency Compliance Requirements

Purchaser's/Owner's Recordkeeping Responsibilities

The United States Environmental Protection Agency (EPA) and Generac Power Systems, Inc. (Generac), are pleased to explain your recordkeeping requirements for compliance with Subpart JJJJ – Standards of Performance for Stationary Spark Ignition Internal Combustion Engines as listed in the Electronic Code of Federal Regulations Title 40 Part 60. As the engine purchaser/owner who operates and maintains their certified emergency stationary engine and emission control system according to applicable emission related guidelines as specified in this Owner's Manual you are required to meet the following notification and recordkeeping requirements to demonstrate compliance. 1.) Maintain documentation that the engine is certified to meet emission standards. 2.) Recordkeeping of maintenance conducted. 3.) Recordkeeping of the provision allowing natural gas engines to operate using propane for a maximum of 100 hours per year as an alternate fuel solely during emergency operations provided the engine is not certified to operate on propane. 4.) Meet all compliance notifications submitted to the purchaser/owner and maintain all supporting documentation. 5.) Recordkeeping of hours of operation, including what classified the operation as emergency and how many hours are spent for non-emergency operation. For emergency engines greater than or equal to 130 HP, recordkeeping of hours of operation begins January 1, 2011. For emergency engines less than 130 HP, recordkeeping of hours of operation begins January 1, 2009; Engines are equipped with non-resettable hour meters to facilitate recordkeeping.

Specific Air Quality Management or Air Pollution Control Districts may have different and additional record keeping/ reporting requirements. Your permit to construct and/or operate the engine may be contingent upon compliance with those requirements. Check with your local Air Quality Management or Air Pollution Control District for specific requirements.

Emergency stationary internal combustion engines (ICE) may be operated for the purpose of maintenance checks and readiness testing, provided that the tests are recommended by Federal, State or local government, Generac, or the insurance company associated with the engine. Maintenance checks and readiness testing of such units is limited to 100 hours per year. There is no time limit on the use of emergency stationary ICE in emergency situations. The purchaser/owner may petition the Administrator for approval of additional hours to be used for maintenance checks and readiness testing, but a petition is not required if the owner maintains records indicating that Federal, State, or local standards require maintenance and testing of emergency ICE beyond 100 hours per year. Emergency stationary ICE may operate up to 50 hours per year in non-emergency situations, but those 50 hours are counted towards the 100 hours per year provided for maintenance and testing. The 50 hours per year for non-emergency situations cannot be used for peak shaving or to generate income for a facility to supply power to an electric grid or otherwise supply power as part of a financial arrangement with another entity. For purchaser/owner of emergency engines, any operation other than emergency operation, maintenance and testing, and operation in non-emergency situations for 50 hours per year, as permitted in this section is prohibited.

If you operate and maintain your certified emergency stationary SI internal combustion engine and emissions control systems in accordance with the specifications and guidelines in the Owner's Manual, EPA will not require engine performance testing. If not, your engine will be considered non-certified and you must demonstrate compliance according to Subpart JJJJ – Standards of Performance for Stationary Spark Ignition Internal Combustion Engines as listed in the Electronic Code of Federal Regulations Title 40 Part 60.

Emission-Related Installation Instructions

Your certified emergency stationary engine has pre-set emission control systems or components that require no adjustment. Inspection and replacement of an emissions related component is required to be done in accordance with the requirements cited in the United States Environmental Protection Agency Warranty Statement or can be arranged by contacting your selling dealer or an Authorized Warranty Service dealer. Failing to follow these instructions when installing a certified engine in a piece of nonroad equipment violates federal law 40 CFR 1068.105 (b), subject to fines or penalties as described in the Clean Air Act.

EXPLODED VIEW: ALT COMMON PARTS 2.4L 10" ALT 22KW & 27KW
 DRAWING #: 0G8881

GROUP A

APPLICABLE TO:

ITEM	PART #	QTY.	DESCRIPTION
1	0G9009	1	RTR-104-22AD1 HI EFF
	0G9011	1	RTR-104-27AD2 HI EFF
	0G9341	1	RTR-104-22GD1 HI EFF
	0G9342	1	RTR-104-27GD2 HI EFF
2	0G8318A	1	HOUSING BLOWER MACHINED 2.4L
3	0G8366	1	BLOWER HOUSING SCREEN
4	020746	3	SCREW PPHM M5-0.8 X 8 ZINC
5	049226	3	WASHER LOCK M5
6	051713	3	WASHER FLAT M5
7	022129	4	WASHER LOCK M8-5/16
8	0G9008	1	STR-104-22AD1 HI EFF
	0G9010	1	STR-104-27AD1 HI EFF
	0G9339	1	STR-104-22GD1 HI EFF
	0G9340	1	STR-104-27GD1 HI EFF
9	0A5382A	1	BEARING CARRIER REAR LG PILOT
10	075591	1	ASSY HOLDER BRUSH
11	051787	4	SCREW HHC M4-0.7 X 16 G8.8
12	0A5601A	1	COVER REAR BEARING
13	0G8827	4	STUD M8-1.25 475 LONG (27KW)
	0G8827A	4	STUD M8-1.25 418 LONG (22KW)
14	0A9375	4	SCREW RHM #10-24 X 2
15	022152	4	WASHER LOCK #10
16	0G8311	1	FLYWHEEL & RINGGEAR ASSY 2.4L
17	042558	1	KEY SQ 3/8 X 1 STEEL
(1) 18	051756	4	SCREW HHC M10-1.5 X 20 C8.8
19	0G8364	1	PLATE FLEX 2.4L 10" ALT
(1) 20	053607	1	SCREW HHC M12-1.75 X 35 G8.8
21	051769	1	WASHER LOCK M12
22	023365	4	WASHER SHAKEPROOF INT #8
(1) 23	0G0114	7	SCREW HHC M12-1.25 X 15 C10.9
24	072578	1	SPACER ROTOR SHAFT
25	0D8427	4	WASHER LOCK M10 RIBBED ZINC
26	0A8830	4	WASHER FLAT .34 ID X .75 OD
27	029333A	7	TIE WRAP UL 7.4"X .19" BLK (NOT SHOWN)
28	063076	7	WASHER FLAT .531ID X 1.062OD
29	045771	4	NUT HEX M8-1.25 G8 CLEAR ZINC
30	077043A	1	CONDUIT FLEX .38"ID (18" LG)
31	077043C	1	CONDUIT FLEX .75"ID (18" LG) (NOT SHOWN)

(1) APPLY MEDIUM STRENGTH BLUE THREADED LOCKING FLUID TO THREADS.

GROUP A

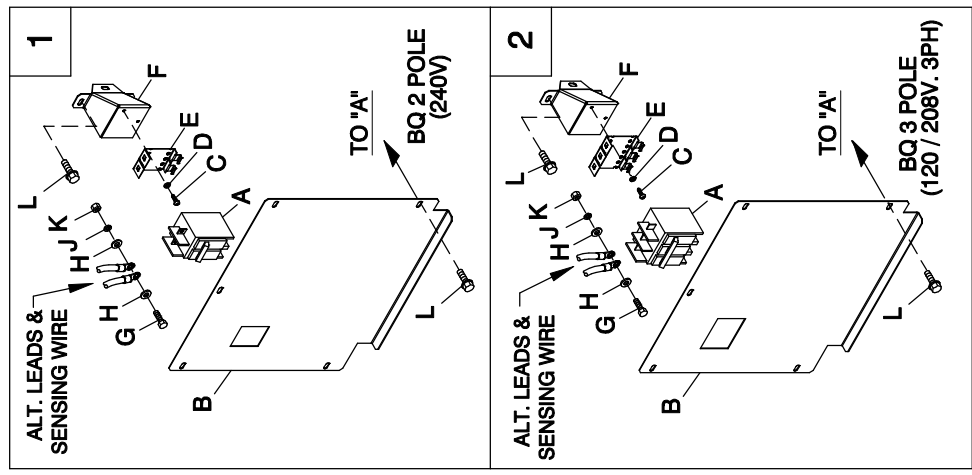
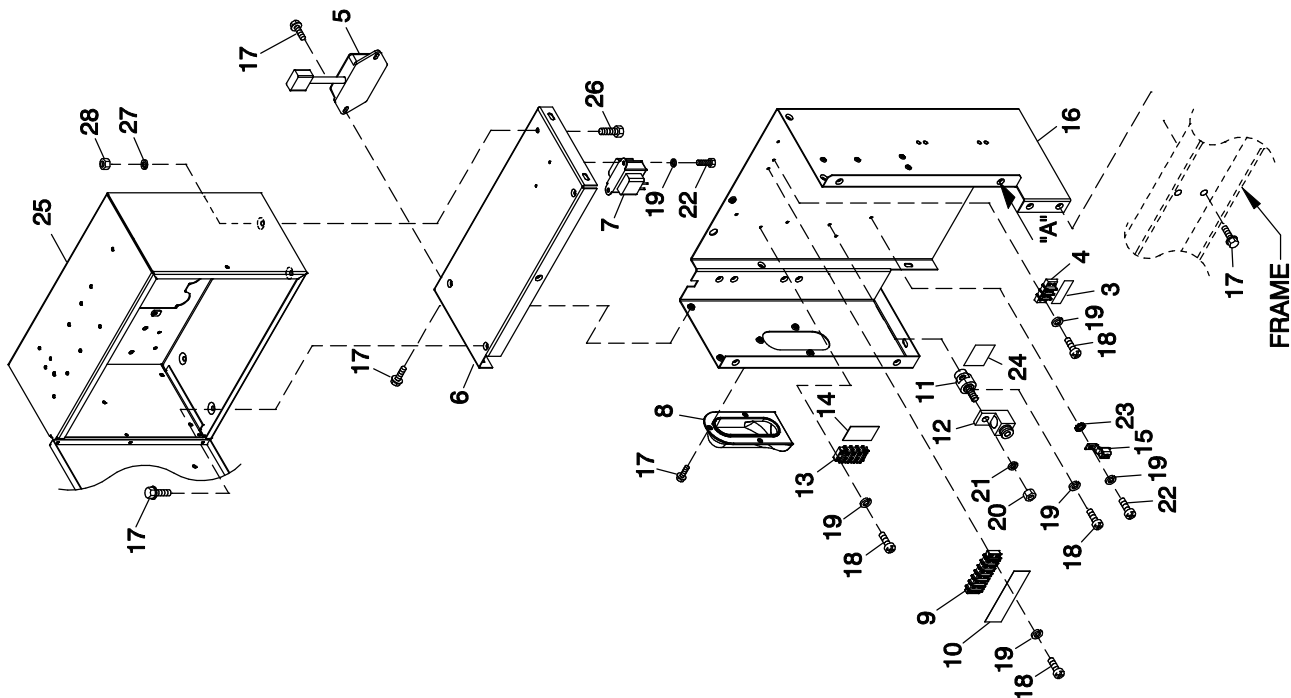

EXPLODED VIEW:
 CONNECTION BOX C1 CPL
 DRAWING #: 0H1711

EXPLODED VIEW: CONNECTION BOX C1 CPL

DRAWING #: 0H1711

GROUP A

APPLICABLE TO:

ITEM	PART #	QTY.	DESCRIPTION
1	N/A	N/A	UL BREAKER BQ2
A	0D5543	1	CB 0090A 2P 240V S BQ2 LL
	0D5544	1	CB 0100A 2P 240V S BQ2 LL
	0A2077	1	CB 0125A 2P 240V S BQ2 LL
B	0G4499	1	CB COVER 20-25K 1P (BQ2)
C	0G9708	2	SCREW PHTT M4-0.7 X 8 ZYC
D	0C2264	2	WASHER LOCK #8-M4
E	0E7890	1	BRKT CB MTG BACK
F	0G4497	1	CIRCUIT BREAKER SUPPORT (BQ)
G	052619	2	SCREW HHC M5-0.8 X 20 G8.8
H	023897	4	WASHER FLAT #10 ZINC
J	049226	2	WASHER LOCK M5
K	051716	2	NUT HEX M5-0.8 G8 CLEAR ZINC
L	0E3257	7	SCREW HWHTF M6-1.0 X 16
2	N/A	N/A	UL BREAKER BQ3
A	049135	1	CB 0070A 3P 240V S BQ3 LL
	062812	1	CB 0080A 3P 240V S BQ3 LL
	040532	1	CB 0100A 3P 240V S BQ3 LL
B	0G4500	1	CB COVER 20-25K 3P (BQ3)
C	0G9708	2	SCREW PHTT M4-0.7 X 8 ZYC
D	0C2264	2	WASHER LOCK #8-M4
E	0E6002	1	BRKT CB MTG BACK
F	0G4497	1	CIRCUIT BREAKER SUPPORT (BQ)
G	052619	3	SCREW HHC M5-0.8 X 20 G8.8
H	023897	6	WASHER FLAT #10 ZINC
J	049226	3	WASHER LOCK M5
K	051716	3	NUT HEX M5-0.8 G8 CLEAR ZINC
L	0E3257	7	SCREW HWHTF M6-1.0 X 16

ITEM	PART #	QTY.	DESCRIPTION
3	0G7991	1	DECAL GTS CUSTOMER CONNECTION
4	048766	REF	BLOCK TERM 20A 2 X 6 X 1100V
5	0A1354A	1	REGULATOR - DC ALT (1.6L ONLY)
6	0G3473	1	CONBOX TOP PANEL SUPPORT
7	0F6366A	1	XFMR 208 TO 16V 6VA (208V. ONLY)
	0F6366B	1	XFMR 240 TO 16V 6VA (240 / 480V.)
8	0G3524	1	COVER BELL HOUSING CONBOX
9	046357	REF	BLOCK TERM 20A 6 X 6 X 1100V
10	0G7992	1	DECAL RTS CUSTOMER CONNECTION
11	057073	1	JUNCTION BLOCK 3/8-16
12	057329	1	LUG SLDLSS 350-#6X13/32 AL/CU
13	0D4698	REF	BLOCK TERM 20A 6 X 3 X 1100V
14	0G9337	1	DECAL CHARGER POWER 120VAC
15	025433	1	LUG SLDLSS #6-14 X 13/64 CU
16	0G3472	1	CONBOX BACK & SIDES 1.6L
17	0E3257	22	SCREW HWHTF M6-1.0 X 16
18	0C2212	8	SCREW PHTT M4-0.7 X 16 ZYC
19	022264	11	WASHER LOCK #8-M4
20	022241	1	NUT HEX 3/8-16 STEEL
21	022237	1	WASHER LOCK 3/8
22	0G9708	3	SCREW PHTT M4-0.7 X 8 ZYC
23	023762	1	WASHER SHAKEPROOF EXT #10 STL
24	0A9457	1	DECAL NEUTRAL
25	0G4577E	REF	ASSY R-200 3600 1.6L
	0G4578E	REF	ASSY R-200 1800 1.6L
	0H1433E	REF	ASSY R-200C 1800 RPM 2.4L
26	047411	1	SCREW HHC M6-1.0 X 16 G8.8
27	022097	1	WASHER LOCK M6-1/4
28	049813	1	NUT HEX M6 X 1.0 G8 YEL CHR

GROUP A

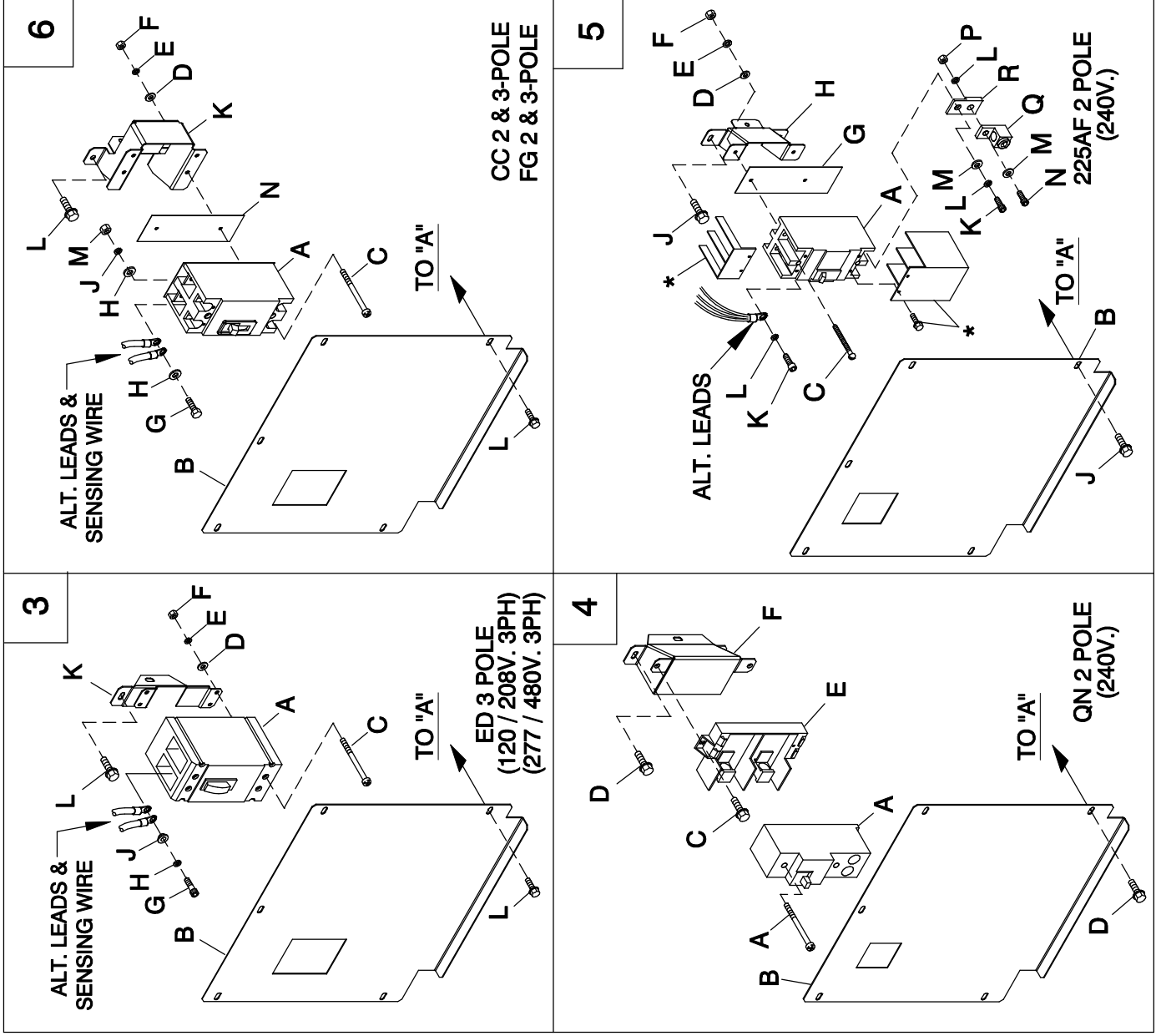

EXPLODED VIEW: CONNECTION BOX C1 CPL
DRAWING #: 0H1711

GROUP A

APPLICABLE TO:

ITEM	PART #	QTY.	DESCRIPTION
3	N/A	N/A	UL BREAKER ED
A	0D5548	1	CB 0030A 3P 480V S ED4 LL
	0D5549	1	CB 0035A 3P 480V S ED4 LL
	0D5551	1	CB 0045A 3P 480V S ED4 LL
	0D5552	1	CB 0050A 3P 480V S ED4 LL
	0D5556	1	CB 0090A 3P 480V S ED4 LL
	0D5557	1	CB 0100A 3P 480V S ED4 LL
	0D9693	1	CB 0125A 3P 480V S ED4 LL
B	0G4502	1	CB COVER 20-30K 3P (ED)
C	066715	4	SCREW RHM #8-32 X 4-1/2
D	038150	4	WASHER FLAT #8 ZINC
E	022264	4	WASHER LOCK #8-M4
F	022471	4	NUT HEX #8-32 STEEL
G	0A8278	3	SCREW SHC 1/4-28 X 3/4 G8.8 NZ
H	022097	3	WASHER LOCK M6-1/4
J	0D5621	3	WASHER-STEP 1/20DX9/32ID BRASS
K	0G4498	1	CIRCUIT BREAKER SUPPORT (ED)
L	0E3257	7	SCREW HWHTF M6-1.0 X 16
4	N/A	N/A	UL BREAKER QN
A	0E7283	1	CB 0150A 2P 240V S QN2 LL
B	0G3474	1	CONBOX FRONT COVER 1.6L QN 2P
C	074908	2	SCREW HHTT M5-0.8 X 10 BP
D	0E3257	7	SCREW HWHTF M6-1.0 X 16
E	0E3664	1	BASE, QN CIRCUIT BREAKER
F	0G4112	1	BREAKER SUPPORT BRACKET 30KW

ITEM	PART #	QTY.	DESCRIPTION
5	N/A	N/A	UL BREAKER
A	0G5249	1	CB 150A 2 POLE 240V 225AF
*	W/CB	2	TERMINAL COVER CB
B	0G5735	1	CB COVER 30K G 225AF
C	053640	2	SCREW RHM #8-32 X 3-1/4
D	038150	2	WASHER FLAT #8 ZINC
E	022264	2	WASHER LOCK #8-M4
F	022471	2	NUT HEX #8-32 STEEL
G	0F8432A	1	INSULATOR CB 2P 225AF
H	0G5734	1	CIRCUIT BREAKER SPPRT G 225AF
J	0E3257	8	SCREW HWHTF M6-1.0 X 16
K	049897	4	SCREW SHC M8-1.25 X 20 G8
L	022129	4	WASHER LOCK M8-5/16
M	022145	6	WASHER FLAT 5/16-M8 ZINC
N	058306	2	SCREW SHC M8-1.25 X 25 G12.9
P	045771	2	NUT HEX M8-1.25 G8 CLEAR ZINC
Q	0F8451	2	LUG SLDLSS 300 MCM-6 AL/CU
R	0F8843	2	BUS BAR 200A LUG ADAPTOR
6	N/A	N/A	CC/FG CIRCUIT BREAKER
A	0H4745	1	CB 0100A 2P 240V E CC LL
	0H4746	1	CB 0125A 2P 240V E CC LL
	0H4747	1	CB 0150A 2P 240V E CC LL
	0H4913	1	CB 0100 3P 240V E CC LL
	0H4914	1	CB 0125 3P 240V E CC LL
	0H5488	1	CB 0080 3P 480V E FG LL
	0H5489	1	CB 0090 3P 480V E FG LL
B	0H4657	1	CB COVER 20-30K 1P (CC)
	0H5392	1	CB COVER 3 POLE TYPE (CC & FG)
(2)C	053640	2 / 4	SCREW RHM #8-32 X 3-1/4 (CC ONLY)
	0H5721	2 / 4	SCREW PPHM #8-32 X 1-3/4 ZINC (FG ONLY)
(2)D	038150	2 / 4	WASHER FLAT #8 ZINC
(2)E	022264	2 / 4	WASHER LOCK #8-M4
(2)F	022471	2 / 4	NUT HEX #8-32 STEEL
(2)G	091526	2 / 3	SCREW PPHM M5-0.8 X 12 ZNC
(2)H	023897	4 / 6	WASHER FLAT #10 ZINC
(2)J	049226	2 / 3	WASHER LOCK M5
K	0H4656	1	CIRCUIT BREAKER SUPPORT (CC)
	0H5604	1	CIRCUIT BREAKER SUPPORT (FD)
L	0E3257	3	SCREW HWHTF M6-1.0 X 16
(2)M	051716	2 / 3	NUT HEX M5-0.8 G8 CLEAR ZINC
(1) N	0H4698	REF	INSULATOR CB 2P E TYPE CC (CC ONLY)
	0H4698A	REF	INSULATOR CB 3P E TYPE CC (CC ONLY)
	0H4698A	1	INSULATOR CB 3P E TYPE CC (FG ONLY)

(1) SUPPLIED WITH BREAKER

(2) QTY. REQ. FOR 2-POLE BREAKERS / QTY. REQ. FOR 3-POLE BREAKERS.

GROUP C

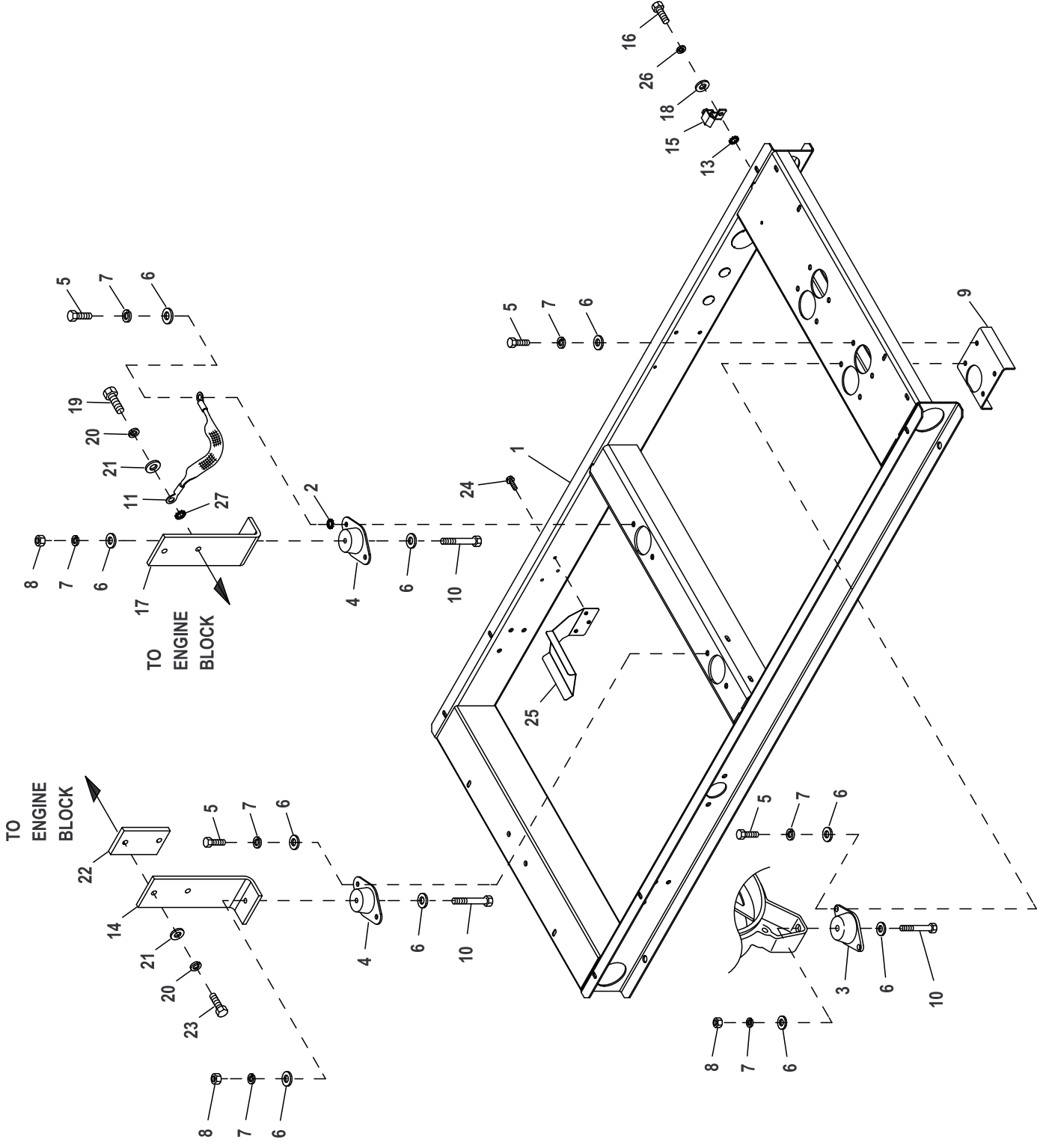

EXPLODED VIEW: MOUNTING BASE 2.4L**DRAWING #: 0G8784****GROUP C****APPLICABLE TO:**

ITEM	PART#	QTY.	DESCRIPTION
1	0G83760ST03	1	MOUNTING BASE 2.4L
2	027482	2	WASHER SHAKEPROOF EXT 5/16 STL
3	070936	2	DAMPENER VIBRATION
4	070936C	2	VIB. ISO. 70-75 DURO
5	039253	12	SCREW HHC M8-1.25 X 20 G8.8
6	022145	20	WASHER FLAT 5/16 ZINC
7	022129	16	WASHER LOCK M8-5/16
8	045771	4	NUT HEX M8-1.25 G8 YEL CHR
9	0G3461	2	ALTERNATOR SUPPORT BLOCK OFF
10	051730	4	SCREW HHC M8-1.25 X 60 G8.8
11	021991	1	EARTH STRAP
13	026850	1	WASHER SHAKEPROOF EXT 1/4 STL
14	0G8429AST03	1	SUPPORT ENGINE LEFT SIDE
15	055414	1	LUG SLDLSS #2-#8 X 17/64 CU
16	047411	1	SCREW HHC M6-1.0 X 16 G8.8
17	0G84290ST03	1	SUPPORT ENGINE RIGHT SIDE
18	022473	5	WASHER FLAT 1/4-M6 ZINC
19	062963	2	SCREW HHC M10-1.25 X 30 C8.8
20	046526	4	WASHER LOCK M10
21	022131	4	WASHER FLAT 3/8-M10 ZINC
22	0F9596A	1	SPACER LH ENGINE MOUNT
23	052211	2	SCREW HHC M10-1.25 X 40 C8.8
24	0C2454	3	SCREW HWHT M6-1 X 16 N WA Z/JS
25	0H6121	1	HEAT SHIELD 2.4L G2
26	022097	1	WASHER LOCK M6-1/4
27	025507	1	WASHER LOCK EXT 7/16 STL

GROUP C

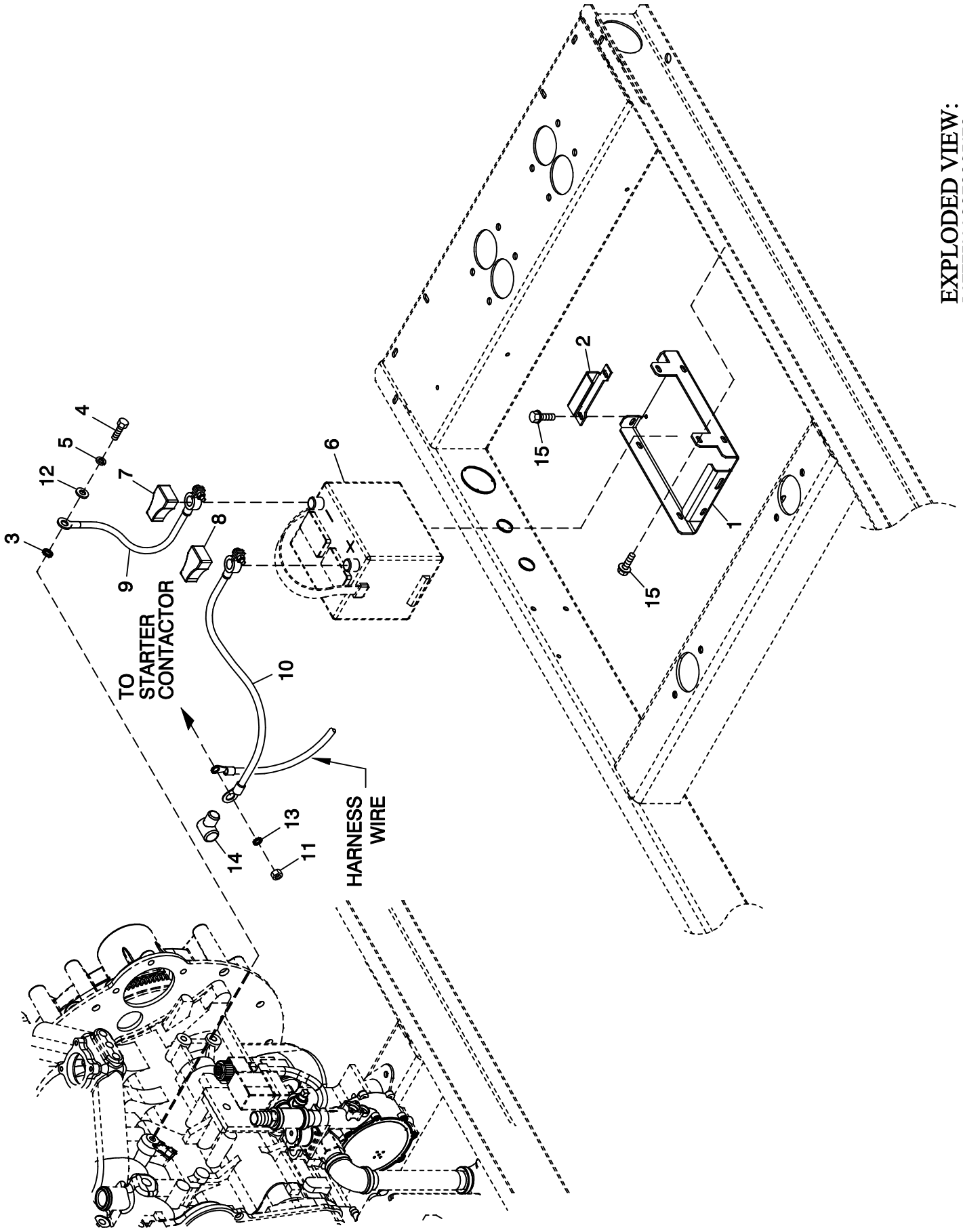

EXPLODED VIEW:
BATTERY ACCESSORIES
DRAWING #: 0G8894

EXPLODED VIEW: BATTERY ACCESSORIES

DRAWING #: 0G8894

GROUP C

APPLICABLE TO:

ITEM	PART #	QTY.	DESCRIPTION
1	0F3408C	1	BATTERY TRAY, C1 & C2
2	0F3411	1	STRAP BATTERY RETAINMENT
3	025507	1	WASHER SHAKEPROOF EXT 7/16 STL
4	052212	1	SCREW HHC M10-1.25 X 25 C8.8
5	046526	1	WASHER LOCK M10
6	077483	REF	BATTERY 12VDC 75-AH 26 (SOLD AS AN OPTION)
7	050331A	REF	BATTERY POST COVER RED +
8	050331	REF	BATTERY POST COVER BLK -
9	038805J	1	CABLE BATTERY BLACK #1 X 30.00
10	038804M	1	CABLE BATTERY RED #1 X 21.00
11	045771	REF	NUT HEX M8-1.25 G8 YEL CHR
12	022131	1	WASHER FLAT 3/8-M10 ZINC
13	027482	1	WASHER SHAKEPROOF EXT 5/16 STL
14	0F3976	1	BOOT CONTACTOR CABLES
15	0C2454	6	SCREW THF M6-1 X 16 N WA Z/JS

GROUP D

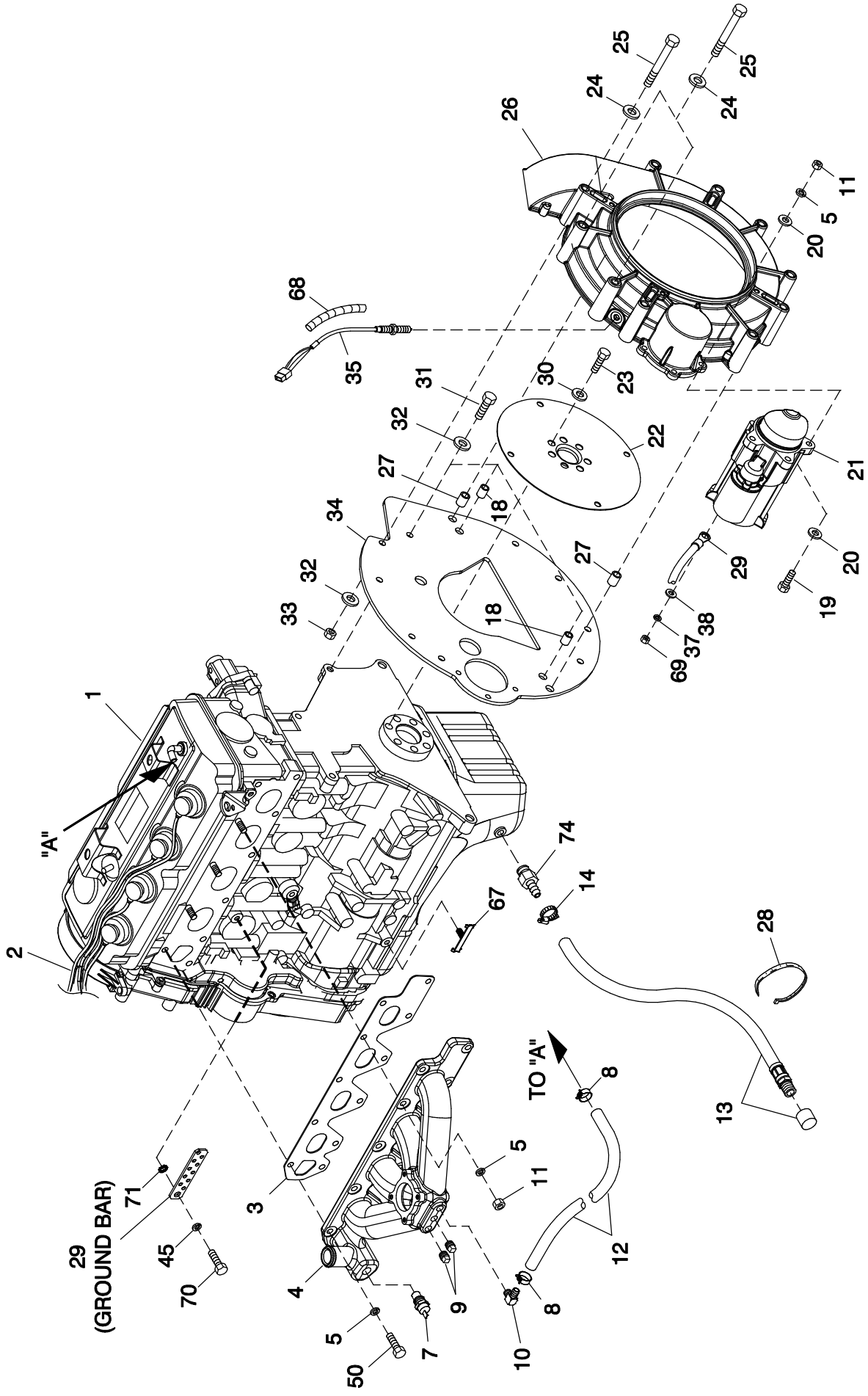

EXPLODED VIEW:
ENG COMMON PARTS 2.4L G2
DRAWING #: 0G8885

GROUP D

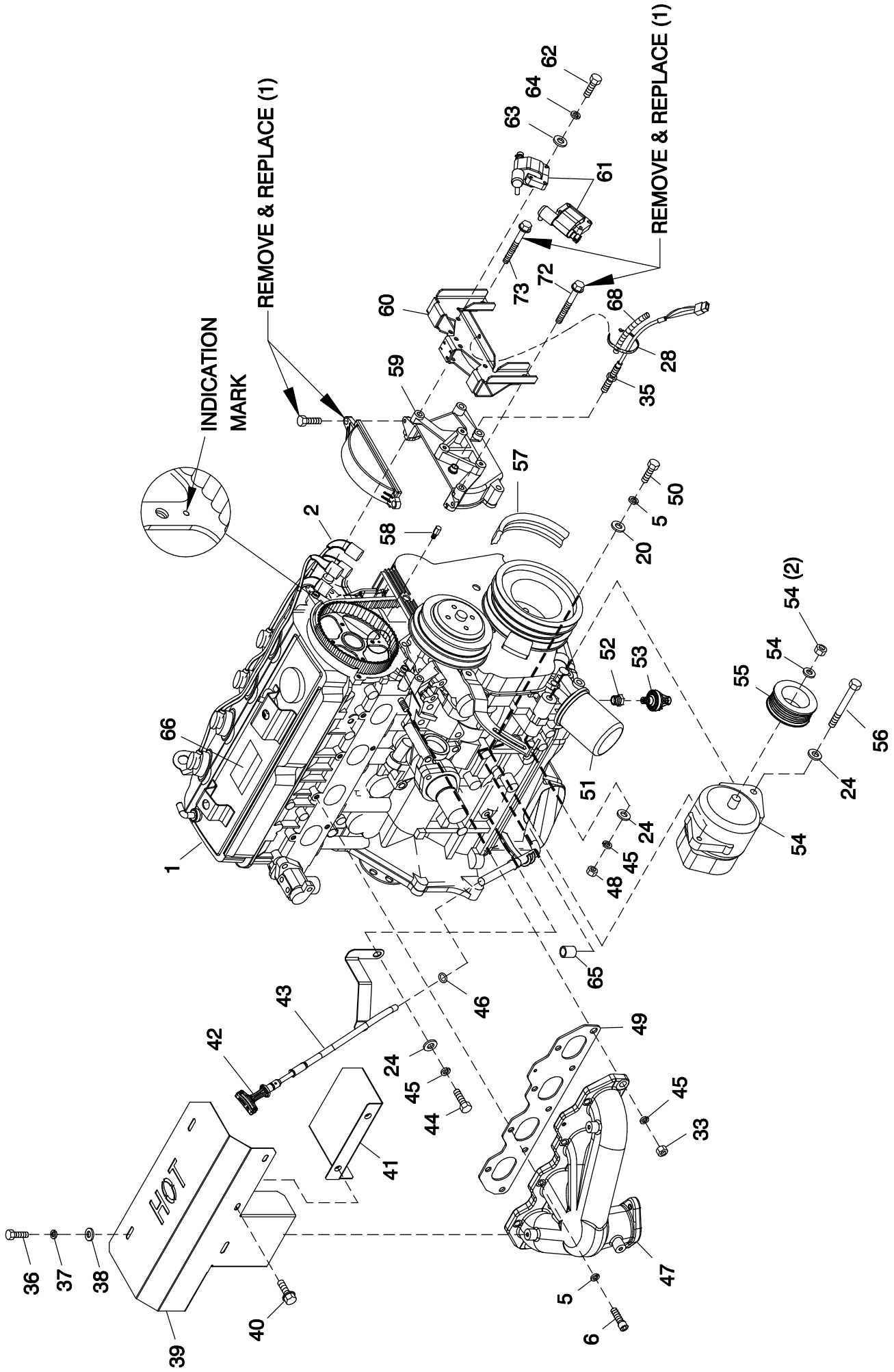

EXPLODED VIEW:
ENG COMMON PARTS 2.4L G2
DRAWING #: 0G8885

EXPLODED VIEW: ENG COMMON PARTS 2.4L G2
DRAWING #: 0G8885

GROUP D

APPLICABLE TO:

ITEM	PART #	QTY.	DESCRIPTION
1	0H1619	1	ENGINE 2.4L G2
2	0G8854	1	SPARK PLUG WIRE SET 2.4L G2 IG
(1) 3	0G0950	1(REF)	GASKET INTAKE MANIFOLD G2
4	0G8488	1	MANIFOLD INTAKE (MACHINED)
5	022129	22	WASHER LOCK M8-5/16
6	058306	7	SCREW SHC M8-1.25 X 25 C12.9
7	0A6751	1	SWITCH HI-TEMP 245D X 3/8 NPT
	0E0502	1	TEMPERATURE SENDER, DELPHI
8	048031J	2	CLAMP HOSE BAND .63
9	026073A	2	PLUG STD PIPE 1/4 STEEL SQ HD
10	049340	1	BARBED EL 90 1/4 NPT X 3/8
11	045771	6	NUT HEX M8-1.25 G8 CLEAR ZINC
12	047290	1	HOSE 3/8 ID SINGLE BRAID (15" LG)
13	069860B	1	HOSE OIL DRAIN ASSY 16"
14	0C7649	1	CLAMP HOSE .38-.87

ITEM	PART #	QTY.	DESCRIPTION
18	0G8759A	2	BUSHING GUIDE 11.3MM LONG
19	039287	3	SCREW HHC M8-1.25 X 45 C8.8
20	022145	7	WASHER FLAT 5/16-M8 ZINC
21	0G7461	1	MOTOR STARTER
22	0G8364	1 (REF)	PLATE FLEX 2.4L 10" ALT
(2) 23	0G0114	7(REF)	SCREW HHC M12-1.25 X 15 C10.9
24	022131	13	WASHER FLAT 3/8-M10 ZINC
25	0G9255	10	SCREW HHC M10-1.25 X 100 PC8.8
26	0G8318A	1 (REF)	HOUSING BLOWER MACHINED 2.4L
27	0G8759	2	BUSHING GUIDE 19.3MM LONG
28	029333A	3	TIE WRAP UL 7.4"X .19" BLK
29	0G8877	1	HARN ENG 2.4L R-200B 1800 NO-T (NOT SHOWN)
	0H1275	1	HARN ENG 2.4L R-200C 1800 RPM (NOT SHOWN)
30	063076	7 (REF)	WASHER FLAT .531 ID X 1.062 OD
31	052830	3	SCREW HHC M10-1.25 X 45 C8.8
32	0D8427	11	WASHER LOCK M10 RIBBED ZINC
33	046525	10	NUT HEX M10-1.25 G8 YEL CHR
34	0G8365	1	ADAPTER ENGINE PLATE 2.4L G2
(2) 35	0D2244M	2	ASSY MAGPICKUP (3/8-24 MALE)
36	043116	3	SCREW HHC M6-1.0 X 12 G8.8
37	022097	4	WASHER LOCK M6-1/4
38	022473	4	WASHER FLAT 1/4-M6 ZINC
39	0G92210AS0R	1	SHIELD EXHAUST
40	0D6029	3	SCREW HHTT M6-1.0 X 16 ZYC
41	0G0792A	1	SHIELD HEAT SML
42	0F2664H	1	ASSY DIPSTICK W/TEXT GTH-530
43	0G8427A	1	ASSY DIPSTICK TUBE 2.4 G2
44	052213	1	SCREW HHC M10-1.25 X 20 C8.8
45	046526	5	WASHER LOCK M10
46	0G3823	1	O-RING SIZE 9.0MM X 2.0MM NITR
47	0G3910	1	EXHAUST MANIFOLD G2 (MACHINE)
48	045772	1	NUT HEX M10-1.5 G8 YEL CHR
(1) 49	0G0951	1(REF)	GASKET EXHAUST MANIFOLD
50	0A8258	9	SCREW HHC M8-1.25 X 25 C10.9
(1) 51	0A45310244	1(REF)	FILTER 1.5L/2.4L G2 OIL
52	042574	1	ADAPTOR 1/8 NPTF TO 1/8 BSPT
53	0A8584	1	SWITCH OIL PRESSURE 10 PSI 2 POL
(2) 54	0E9868A	1	ALTERNATOR DC W/OUT PULLEY
55	0G2750	1	PULLEY 69 OD DC ALTERNATOR
56	0E4507	1	SCREW HHC M10-1.5 X 120 C8.8
57	0D3488S	1	BELT SERPENTINE 37.0"
58	0G1472A	1	CAM SENSOR PIN ASSY
59	0G1477	1(REF)	COVER CAM GEAR G2 REWORKED
60	0G8852	1	BRACKET ASM-2.4L COIL G2
61	0G8853	4	COIL-2.4L G2 IGNITION
62	034413	8	SCREW HHM #10-32 X 1-1/4
63	023897	8	WASHER FLAT #10 ZINC
64	022152	8	WASHER LOCK #10
(1) 65	0G9520	1 (REF)	PLUG TAPER
66	0G7313	1 (REF)	DECAL EMISSION CTRL INFO 2.4L
67	0F4001E	1	ANCHOR HARNESS
68	077043H	2	CONDUIT FLEX .25"ID (6"LG)
69	049813	1	NUT HEX M6 X 1.0 G8 YEL CHR
70	052213	1	SCREW HHC M10-1.25 X 20 C8.8
71	025507	1	WASHER SHAKEPROOF EXT 7/16 STL
(1) 72	052265	1(REF)	SCREW HHC M8-1.25 X 65 C8.8
(1) 73	052203	1(REF)	SCREW HHC M8-1.25 X 70 C8.8
74	0C1852	1	ADAPTER DRAIN OIL

(1) SUPPLIED WITH ENGINE.
(2) APPLY MEDIUM STRENGTH BLUE THREAD
LOCKING FLUID TO THREADS.

APPLICABLE TO:

THIS PAGE IS LEFT INTENTIONALLY BLANK

GROUP C

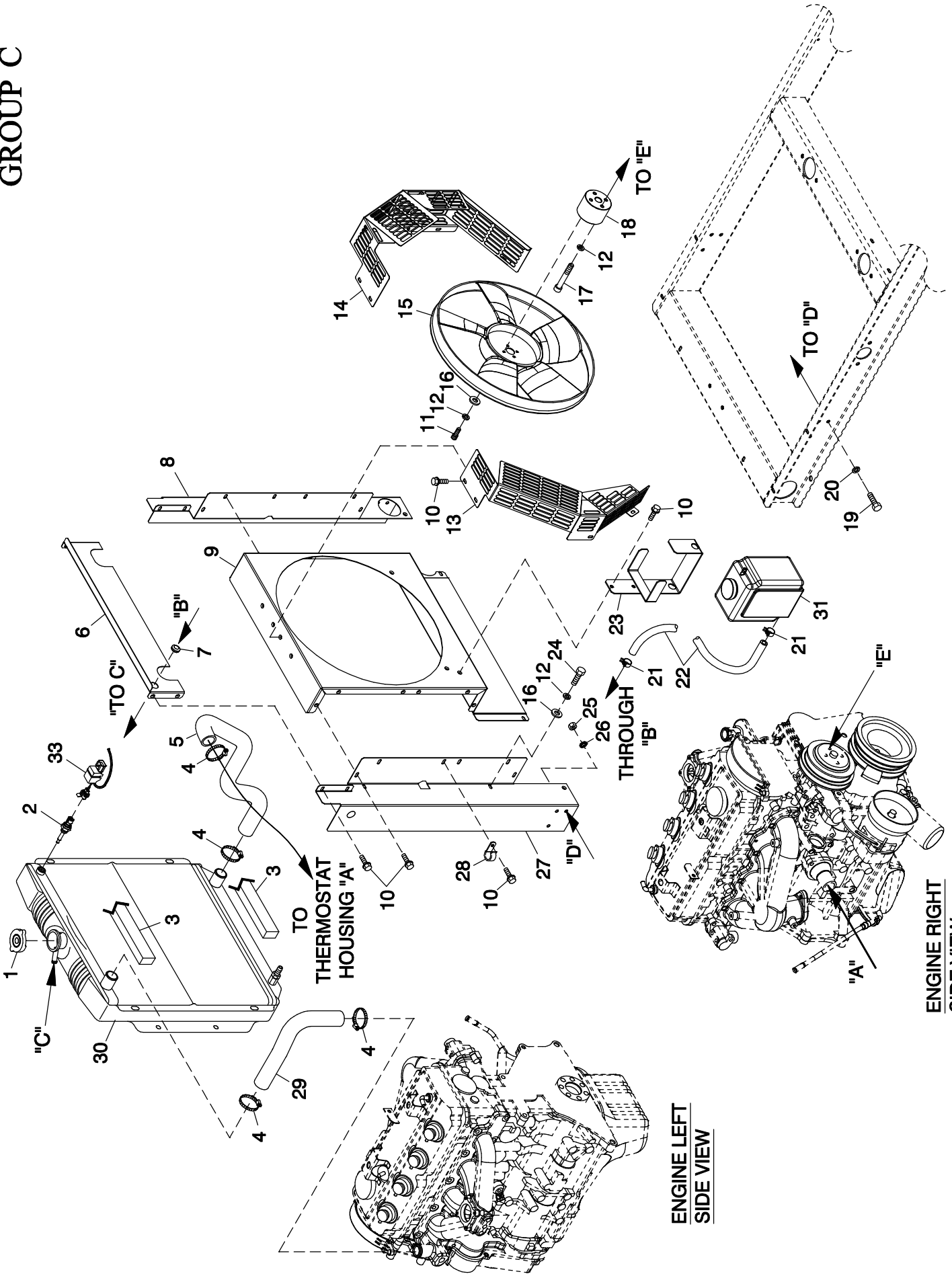

EXPLODED VIEW: COOLING SYSTEM 2.4L C1

DRAWING #: 0G8886

GROUP C

APPLICABLE TO:

ITEM	PART #	QTY.	DESCRIPTION
1	046627	1	CAP RADIATOR 14PSI
2	0E2507	1	PROBE COOLANT LEVEL 3/8NPTF
	0H1827	1	PROBE COOLANT LEVEL 3/8-18NPTF (USE WITH I/N 33, P/N 0H1851)
3	052250	2	TAPE FOAM 1 X 1 (21" LG)
4	099502	4	CLAMP HOSE #24 B1.06-2.00
5	0G8831	1	HOSE LOWER RADIATOR 2.4L
6	0G81290GS0R	1	BLOCK OFF RADIATOR 2.4L
7	0F9504	1	GROMMET 5/8"X 1 1/8"X 5/16"
8	0G81280GS0R	1	SUPPORT RADIATOR RH SIDE 2.4L
9	0G81260GS0R	1	VENTURI 2.4L
10	0C2454A	25	SCREW THF M6-1 X 12 N WA Z/JS
11	042568	4	SCREW HHC M6-1.0 X 20 G8.8
12	022097	12	WASHER LOCK M6-1/4
13	0G89420GS0R	1	GUARD FAN LH
14	0G89430GS0R	1	GUARD FAN RH
15	0G8803	1	FAN COOL 460MM DIA 5 BLADE
16	022473	8	WASHER FLAT 1/4-M6 ZINC
(1) 17	082460	4	SCREW SHC M6-1.0 X 65 C12.9
18	0G8993	1	ADAPTER FAN 2.4L
(1) 19	039253	6	SCREW HHC M8-1.25 X 20 G8.8
20	022129	6	WASHER LOCK M8-5/16
(2) 21	048031C	2 (REF)	CLAMP HOSE BAND 1/4
22	029032	1	HOSE 9/32 ID (47" LG)
23	080713	1	BRACKET COOLANT TANK
24	0C8566	4	SCREW HHFC M6-1.0 X 20 G8.8
25	045771	6	NUT HEX M8-1.25 G8 CLEAR ZINC
26	027482	6	WASHER SHAKEPROOF EXT 5/16 STL
27	0G81270GS0R	1	SUPPORT RADIATOR LH SIDE 2.4L
28	082121A	1	CLIP-J VINYL COAT .375 ID
29	0G8830	1	HOSE UPPER RADIATOR 2.4L
30	0E9837C	1	RADIATOR
31	076749	1	TANK COOLANT RECOVERY
32	029333A	9	TIE WRAP UL 7.4" X .19" BLK (NOT SHOWN)
(3) 33	0H1851	1	ASSY PCB LCL SENSOR (USE WITH I/N 2, P/N 0H1827 ONLY)

(1) APPLY MEDIUM STRENGTH BLUE THREAD LOCKING FLUID TO THREADS.

(2) INCLUDED WITH I/N 25.

(3) USE WITH R-200 CONTROL PANEL ONLY.

GROUP E

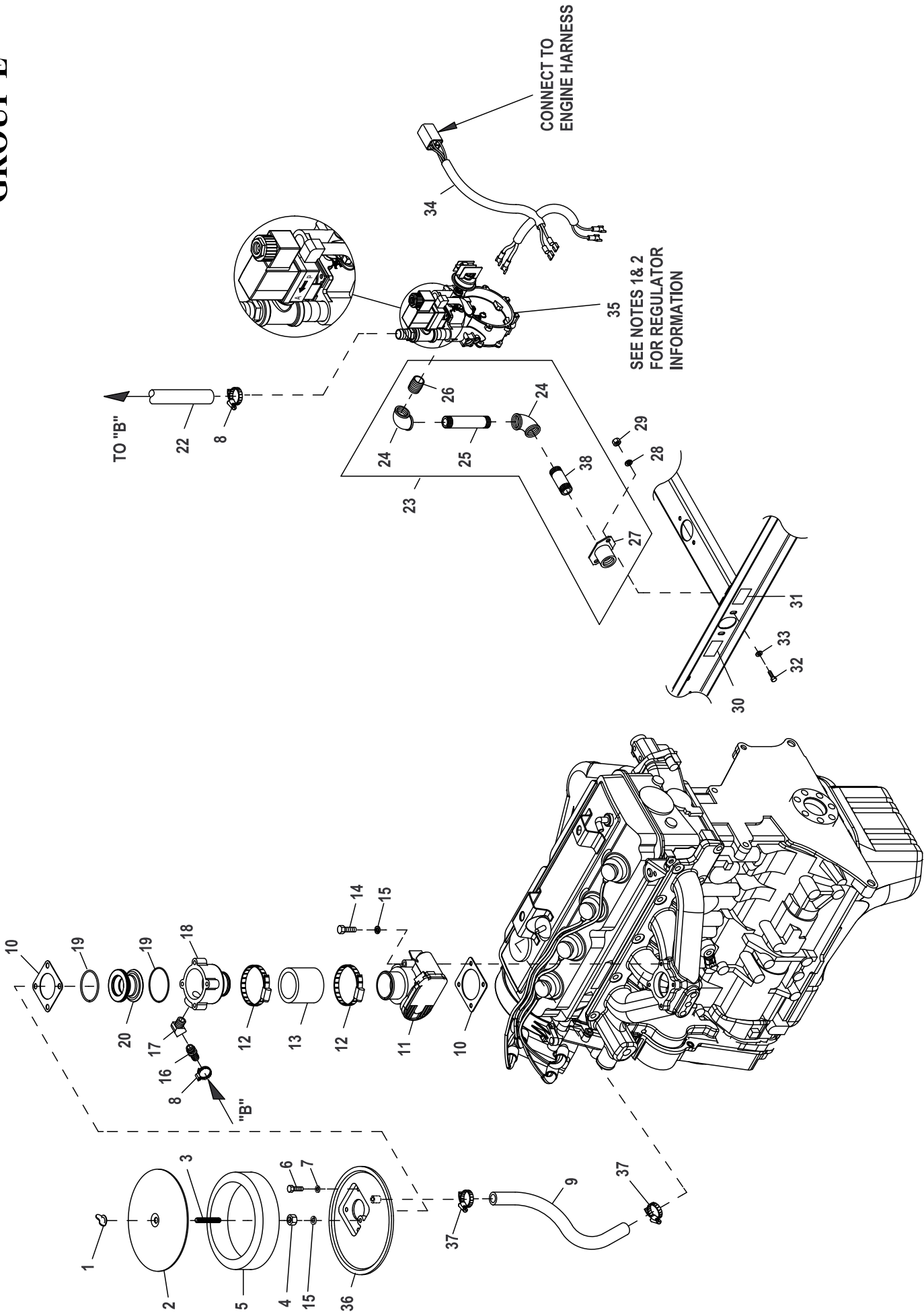

EXPLODED VIEW: FUEL SYSTEM 2.4L G2 22&27KW**DRAWING #: 0G8814****GROUP E****APPLICABLE TO:**

ITEM	PART#	QTY.	DESCRIPTION
1	037561	1	NUT WING 1/4-20 NYLK
2	0A5547	1	COVER AIR CLEANER
3	062522	1	STUD TH 1/4-20 X 3 G2 ZNC FULL
4	022127	1	NUT HEX 1/4-20 STEEL
5	059402	1	FILTER ELEMENT
6	091526	4	SCREW PPHM M5-0.8 X 12 ZNC
7	049226	4	WASHER LOCK M5
8	057823	2	CLAMP HOSE #10 .56-1.06
9	047290	1	HOSE 3/8 ID SINGLE BRAID (15" LG)
10	0E6586	2	GASKET BOSCH 32
11	0E4395	1	ACTUATOR BOSCH 32 GOVERNOR (25 & 35KW)
12	035685	2	CLAMP HOSE #28 1.32-2.25
13	057753B	1	HOSE 1.5 ID X 2 LG 20R4 (35KW)
14	051767	4	SCREW HHC M6-1.0 X 45 C8.8 FTH
15	022097	5	WASHER LOCK M6-1/4
16	047527	1	BARBED STR 1/2 NPT X 3/4
17	0E8286	1	STREET EL 45D 1/2 NPT BRASS
18	0G4573C	1	MIXER ACTUATOR 32MM MACHINED (25KW)
19	0E7121	2	O-RING 47.625 ID X 2.38 WIDTH
20	0F7790H	1	VENTURI THROTTLE 19MM (25KW)
22	059057	1	HOSE 3/4 ID SAE-30R2 (18" LG)
23	0G9348	1	ASSY REG INLET NPT FITTINGS
(1) 24	026812	2	ELBOW 90D 3/4 NPT
(1) 25	076691	1	NIPPLE PIPE 3/4NPTX4.5 BLK IRN
(1) 26	026915	1	NIPPLE CLOSE 3/4 X 1.375
(1) 27	075580	1	FLANGE FUEL INLET
28	022129	2	WASHER LOCK M8-5/16
29	045771	2	NUT HEX M8-1.25 G8 YEL CHR
30	0D1509	1	DECAL INLET PRESSURE
(2) 31	075436	1	DECAL - FUEL INLET
32	039253	2	SCREW HHC M8-1.25 X 20 G8.8
33	022145	2	WASHER FLAT 5/16 ZINC
34	0F6155	1	HARNES FUEL JUMPER SINGLE REG
35	0G1397C	1	FUEL REG REWORK 2.4 1800 22/27
36	0E0519A	1	ADAPTER, CARBURETOR W/PVC CONN
37	048031J	2	CLAMP HOSE BAND .63
(1) 38	026490	1	NIPPLE PIPE 3/4NPT X 2

(1) INCLUDED IN I/N 23 (REGULATOR ASY)

(2) FOR LP VAPOR APPLICATION SUBSTITUE LPG FUEL INLET DECAL P/N 050280 FOR NG FUEL INLET DECAL P/N 050279 (ITEM 31).

NOTES:

1. REGULATOR (I/N 35) AS SHOWN IN ILLUSTRATION IS SET UP FOR NATURAL GAS APPLICATION.

2. TO CONFIGURE REGULATOR FOR LP VAPOR, REFER TO THE "RECONFIGURING THE FUEL SYSTEM" SECTION OF THIS MANUAL.

GROUP F

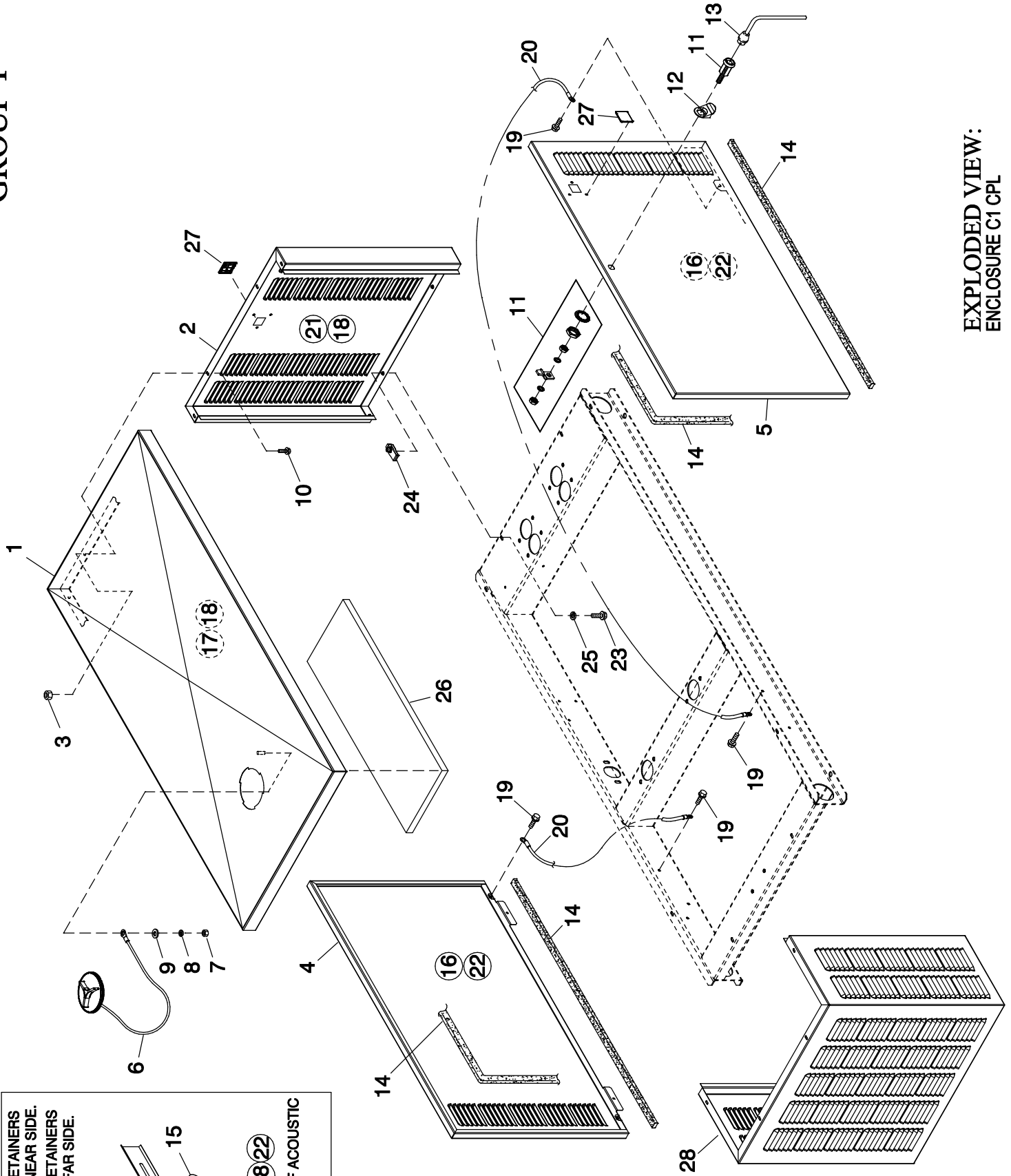

○ INSULATION AND RETAINERS LOCATED ON THE NEAR SIDE.
 ○ INSULATION AND RETAINERS LOCATED ON THE FAR SIDE.

RETAINER 18 22

TYPICAL MOUNTING OF ACOUSTIC INSULATION.

EXPLODED VIEW:
ENCLOSURE C1 CPL
DRAWING #: 0G3534

APPLICABLE TO:

ITEM	PART #	QTY.	DESCRIPTION
(2) 1	0G33370ST0R	1	ROOF 1.6L C1
(2) 2	0G33360ST0R	1	REAR INTAKE WRAP 1.6L C1
(1) 3	077992	10	NUT HEX LOCK M6-1.0 SS NY INS
(2) 4	0G33410ST0R	1	DOOR LEFT/RIGHT SIDE 1.6L C1
(2) 5	0G3341AST0R	1	DOOR LEFT/RIGHT SIDE 1.6L C1
6	0F4487A	1	ASSY ACCESS COVER
7	022127	1	NUT HEX 1/4-20 STEEL
8	022097	1	WASHER LOCK M6-1/4
9	022473	1	WASHER FLAT 1/4-M6 ZINC
10	0C2454	10	SCREW THF M6-1 X 16 N WA Z/JS
11	0F5048D	2	WISE-ACTION LATCH, SLOTTED CIR
12	0F5049	2	TAB PULL
13	0F8869D	1	KEY VISE-ACTION LATCH, SLOT CIR
14	089961	1	FOAM STRIP 3/4"WIDE X 3/16"THK (294"LG)
15	078115	18	WASHER SELF LOCKING DOME
16	0H7518	2	INSULATION SIDE DOOR C1
17	0H7518A	1	INSULATION ROOF C1
18	0F3890	5	RETAINER INSULATION (450)
19	0E3257	4	SCREW HWHTF M6-1.0 X 16
20	0912970090	2	ASSY WIRE 14AWG GRN/YEL (32.25"LG)
21	0H7518B	1	INSULATION REAR C1
22	0F3890B	4	RETAINER INSULATION (820)
23	0C8566	10	SCREW HHFC M6-1.0 X 20 G8.8
24	0H0412	10	NUT SPRINGCLIP M6-1.0
25	022097	10	WASHER LOCK M6-1/4
(3) 26	0H7529	1	FOIL ALUMINUM WITH ADHESIVE
27	0H1208A	2	RF COVER PLATE-PLASTIC-BISQUE
	0H1208B	2	RF COVER PLATE-PLASTIC-GREY
(2) 28	0G33350ST0R	1	FRONT DISCHARGE WRAP 1.6L C1

(1) ALUMINUM ENCLOSURE NOTE: ALL ROOF PANELS ARE TO BE SECURED USING ITEM NUMBERS 10 (THREAD FORMING FASTENER) & 3 (LOCK NUT). THE LOCK NUT IS TO BE INSTALLED AFTER THREAD FORMING FASTENER HAS PENETRATED THROUGH EXTRUSIONS IN ENCLOSURE PANELS.

(2) SHEET METAL PARTS LISTED IN THE BOM TABLE ARE REPRESENTING GENERIC PARTS (NO COLOR).

- MANUFACTURING: FOR CORRECT MATERIAL AND COLOR REFER TO AS400 BOM.
- CUSTOMER: FOR CORRECT MATERIAL AND COLOR OF REPLACEMENT PARTS REFER TO "REPLACEMENT SHEET METAL PARTS ORDERING GUIDE-0H7169" INCLUDED IN THE MANUAL OR AVAILABLE ON THE GENERAC WEBSITE.

(3) USED ON 1.6L UNITS ONLY.

GROUP F

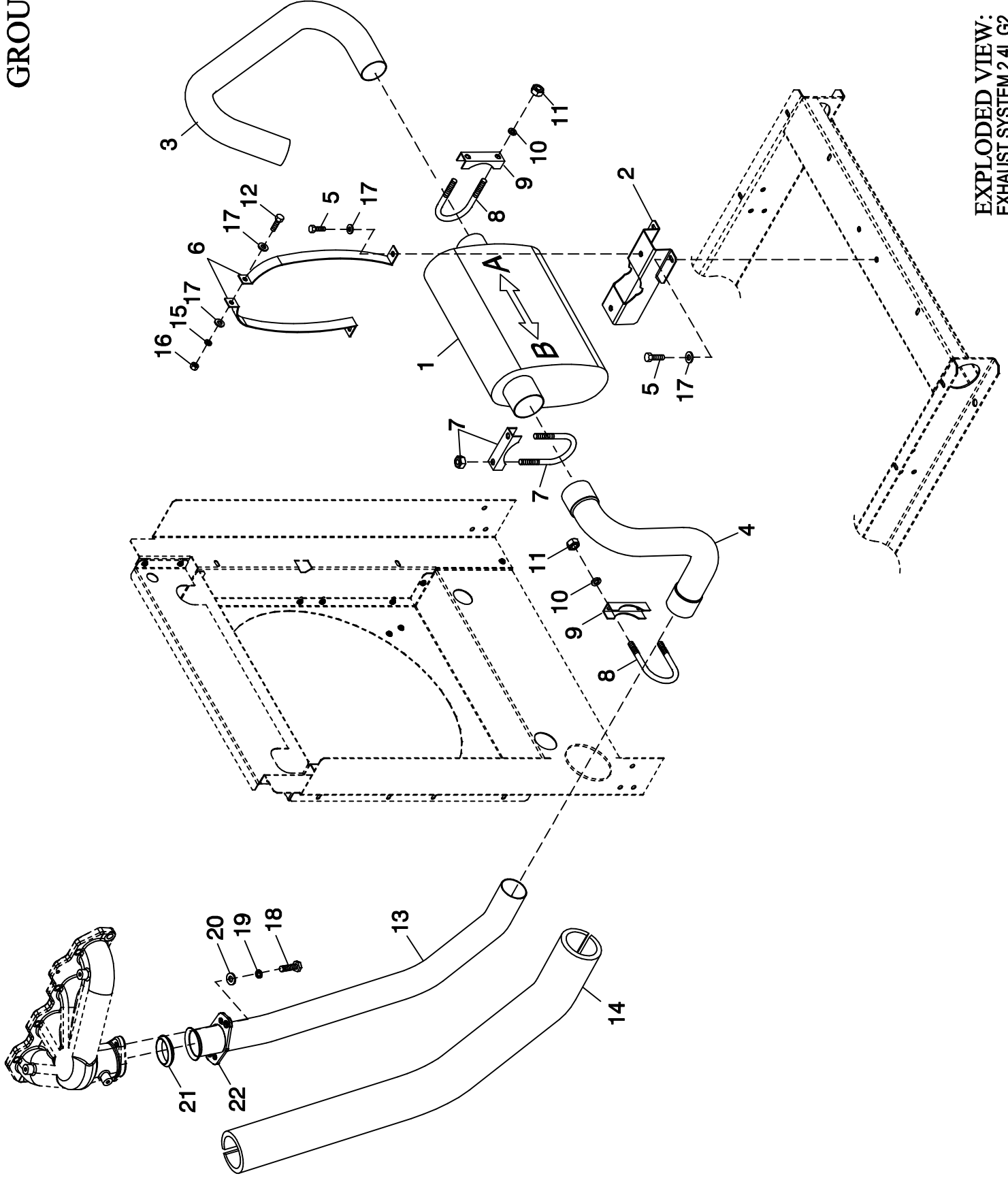

EXPLODED VIEW:
EXHAUST SYSTEM 2.4L G2
DRAWING #: 0G8890

EXPLODED VIEW: EXHAUST SYSTEM 2.4L G2**DRAWING #: 0G8890****GROUP F**

APPLICABLE TO:

ITEM	PART #	QTY.	DESCRIPTION
1	0F7366	1	MUFFLER C1
2	0F7647	1	MUFFLER SADDLE
3	0F8095	1	PIPE EXHAUST OUTLET
4	0G8614	1	EXHAUST ELBOW 2.4L G2
5	0E3257	4	SCREW HWHTF M6-1.0 X 16
6	0F7644	2	MUFFLER STRAP
7	0C6119	1	BOLT U 5/16-18 X 2-1/4
8	036434	2	BOLT U 5/16-18 X 2.09
9	036449	2	SADDLE 2 INCH
10	022129	4	WASHER LOCK M8-5/16
11	022259	4	NUT HEX 5/16-18 STEEL
12	038750	1	SCREW HHC M6-1.0 X 30 G8.8
13	0G8613	1	EXHAUST PIPE 2.4L G2
14	0F3794B	1	EXHAUST BLANKET 700MM LONG
15	022097	1	WASHER LOCK M6-1/4
16	049813	1	NUT HEX M6 X 1.0 G8 YEL CHR
17	022473	6	WASHER FLAT 1/4-M6 ZINC
18	0D2611	2	SCREW HHC 3/8-16 X 1-3/4 SS
19	085917	2	WASHER LOCK 3/8 SS
20	088775	2	WASHER FLAT 3/8 SS
21	044149	1	GASKET EXHAUST RING
22	0E8816	1	FLANGE EXHAUST 2" PIPE

OPTION 1 - SINGLE PHASE, R-SERIES CONTROL PANEL, 240V

LEGEND

- AR = ALTERNATOR ROTOR
- AS = ALTERNATOR STATOR
- MLCB = MAIN CIRCUIT BREAKER
- NB = NEUTRAL BLOCK

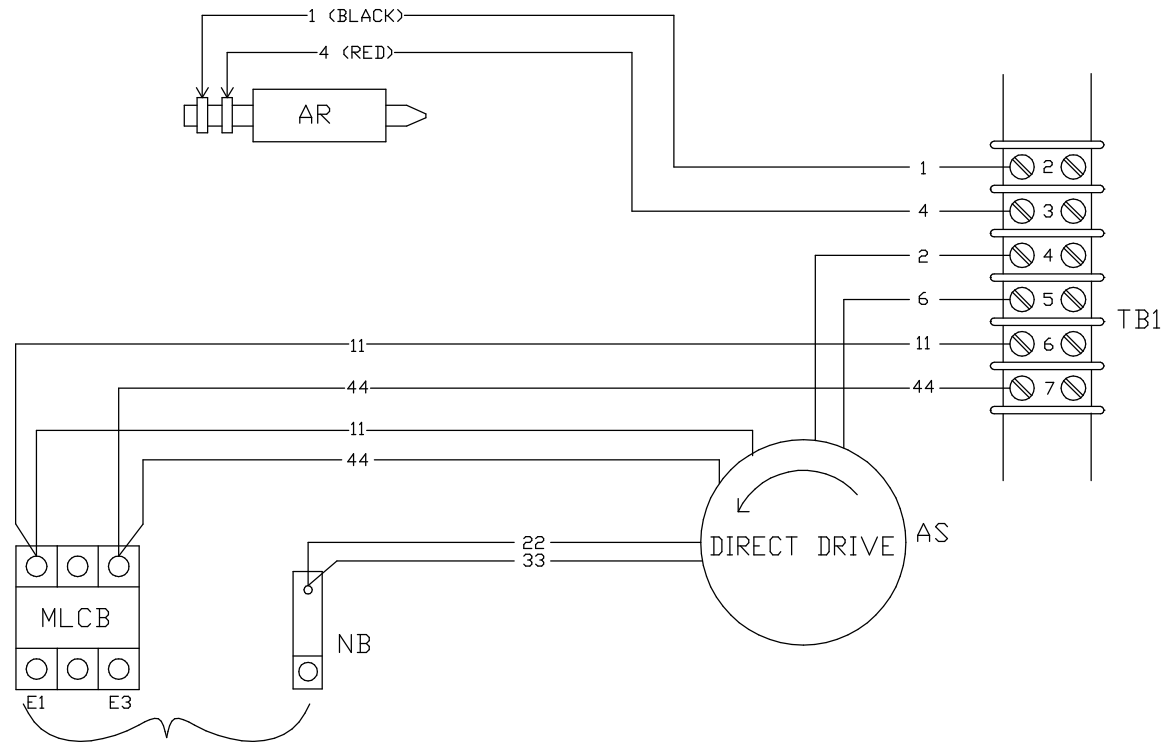

GENERATOR OUTPUT
CUSTOMER CONNECTION

- E1 - E3 = 240VAC
- E1 - NB = 120VAC
- E3 - NB = 120VAC

OPTION 2 - THREE PHASE, R-SERIES CONTROL PANEL, 6-WIRE 120/208V

LEGEND

- AR = ALTERNATOR ROTOR
- AS = ALTERNATOR STATOR
- MLCB = MAIN CIRCUIT BREAKER
- NB = NEUTRAL BLOCK

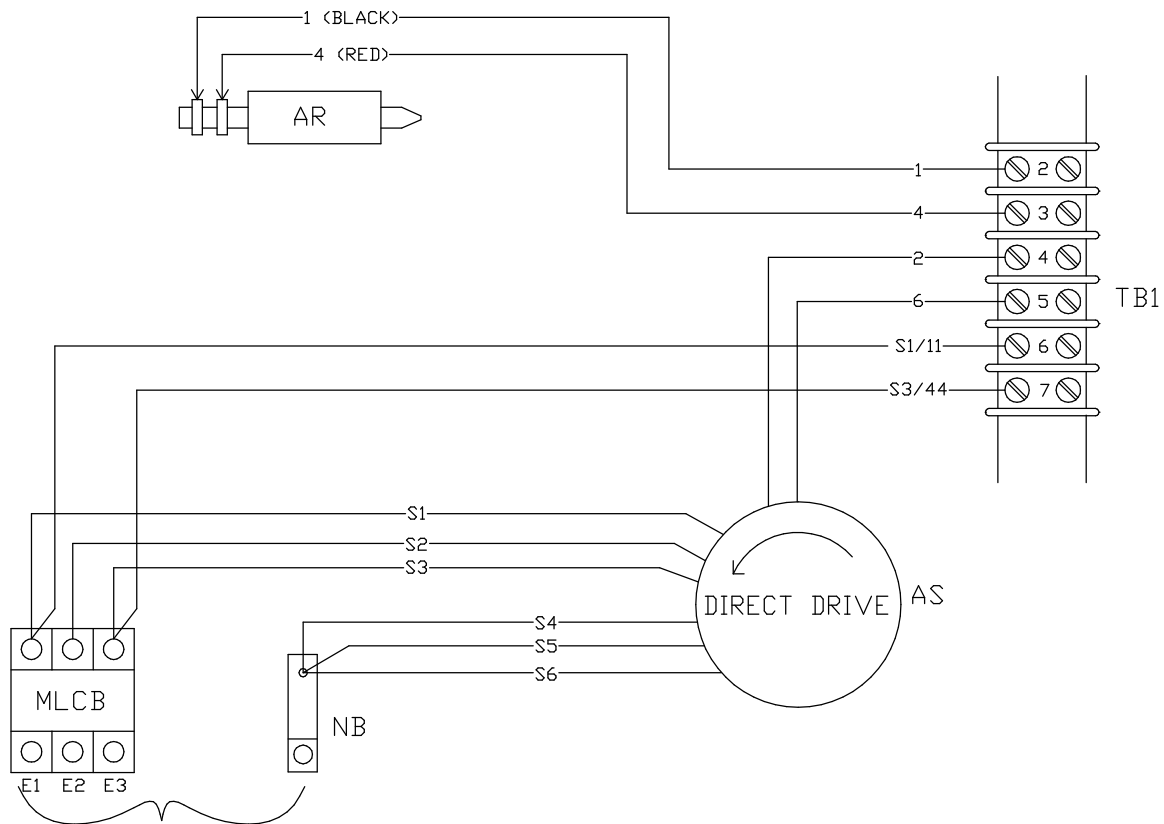

GENERATOR OUTPUT
CUSTOMER CONNECTION

E1 TO E2 }
E2 TO E3 } *208VAC
E1 TO E3 }

E1, E2, OR E3 TO NB = * 120VAC

*NOTE: THE 8th DIGIT OF THE MODEL NUMBER SPECIFIES OUTPUT VOLTAGE

"G" = 120/208VAC

OPTION 3 - THREE PHASE, R-SERIES CONTROL PANEL, 6-WIRE 277/480V

LEGEND

- AR = ALTERNATOR ROTOR
- AS = ALTERNATOR STATOR
- MLCB = MAIN CIRCUIT BREAKER
- NB = NEUTRAL BLOCK

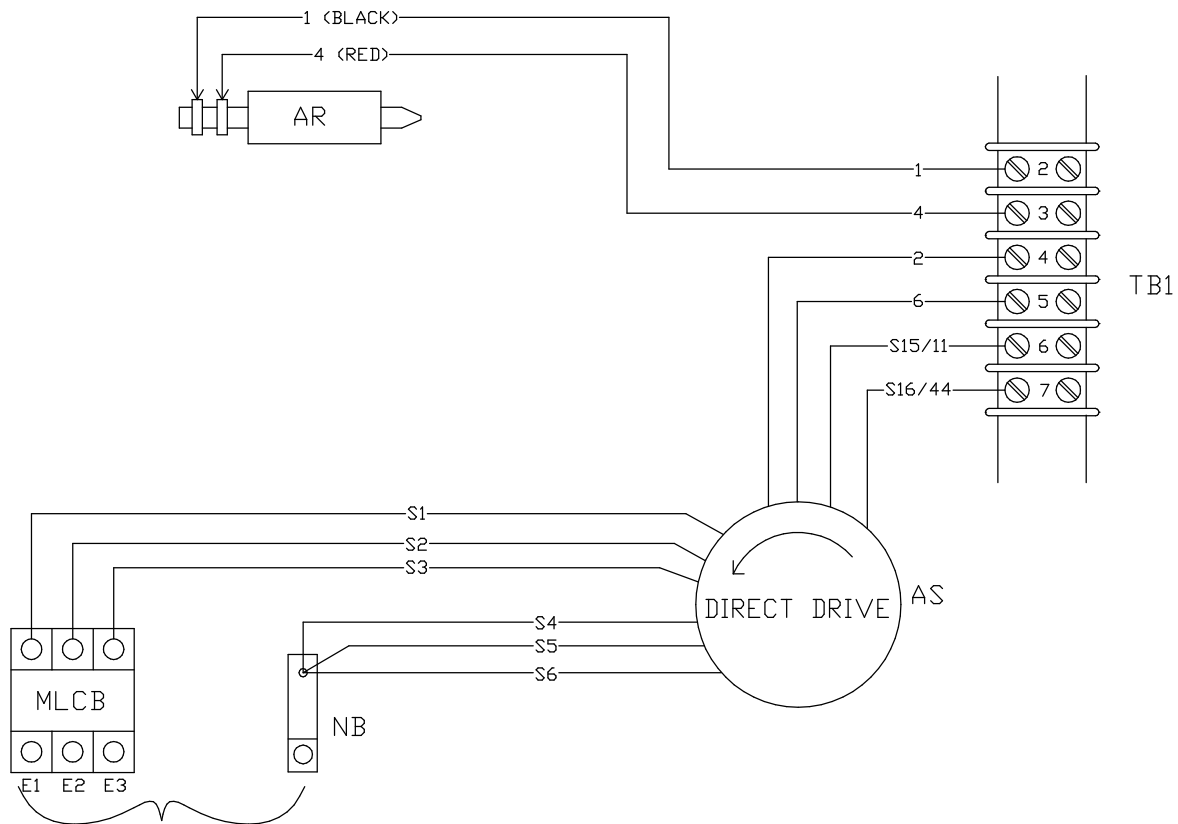

GENERATOR OUTPUT
CUSTOMER CONNECTION

E1 TO E2 }
E2 TO E3 } *480VAC
E1 TO E3 }

E1, E2, OR E3 TO NB = * 277VAC

*NOTE: THE 8th DIGIT OF THE MODEL NUMBER SPECIFIES OUTPUT VOLTAGE

"K" = 227/480VAC

OPTION 4 - THREE PHASE, R-SERIES CONTROL PANEL, 12-WIRE 120/208

LEGEND

- AR = ALTERNATOR ROTOR
- AS = ALTERNATOR STATOR
- MLCB = MAIN CIRCUIT BREAKER
- NB = NEUTRAL BLOCK

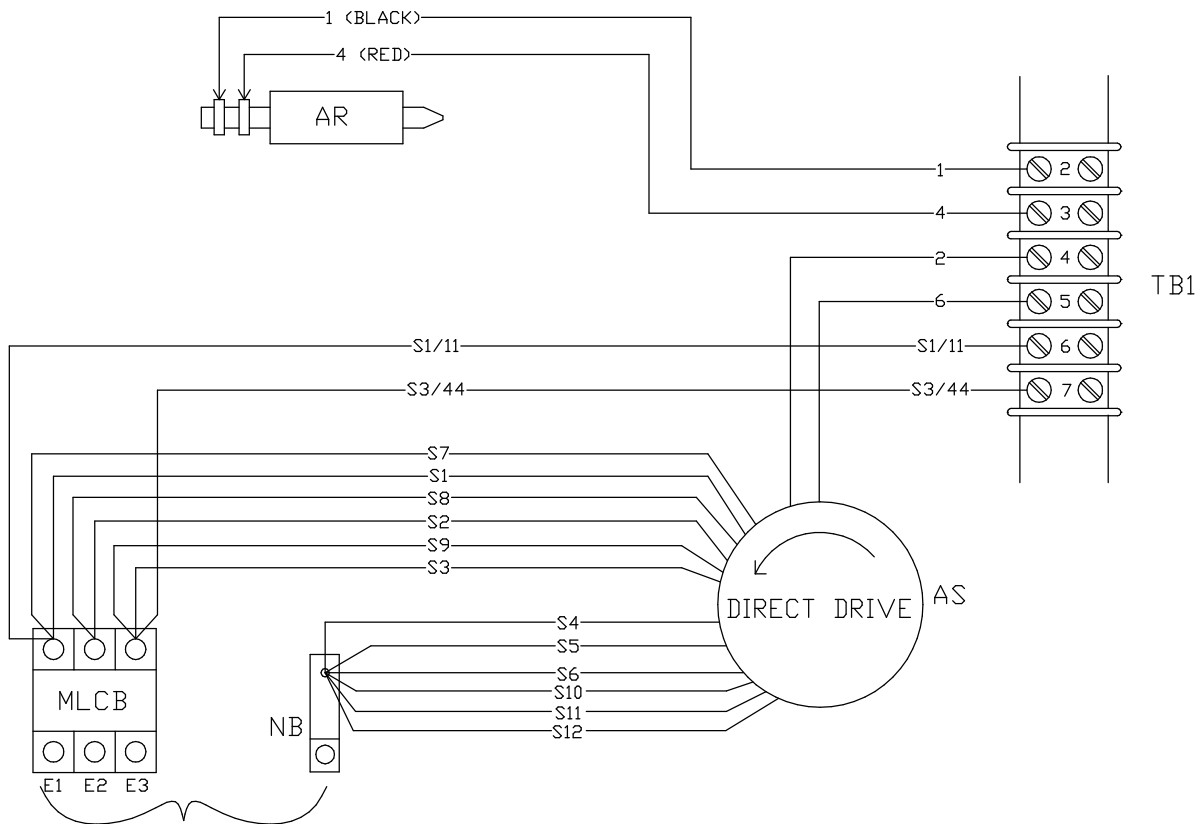

GENERATOR OUTPUT
CUSTOMER CONNECTION

E1 TO E2 }
E2 TO E3 } *208VAC
E1 TO E3 }

E1, E2, OR E3 TO NB = * 120VAC

*NOTE: THE 8th DIGIT OF THE MODEL NUMBER SPECIFIES OUTPUT VOLTAGE

"G" = 120/208VAC

OPTION 5 - THREE PHASE DELTA, R-SERIES CONTROL PANEL, 7-WIRE 120/240V

LEGEND

- AR = ALTERNATOR ROTOR
- AS = ALTERNATOR STATOR
- MLCB = MAIN CIRCUIT BREAKER
- NB = NEUTRAL BLOCK

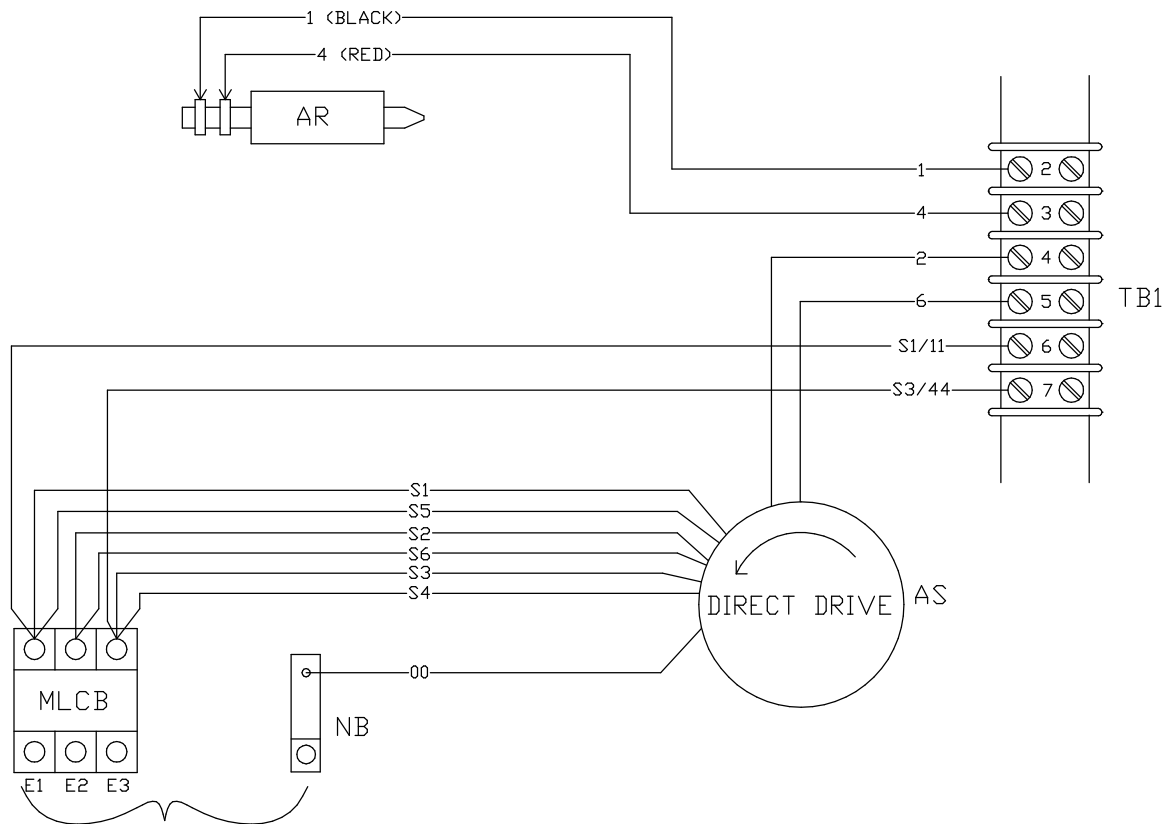

GENERATOR OUTPUT
CUSTOMER CONNECTION

E1 TO E2 }
E2 TO E3 } *240VAC
E1 TO E3 }

E1, OR E3 TO NB = * 120VAC

*NOTE: THE 8th DIGIT OF THE MODEL NUMBER SPECIFIES OUTPUT VOLTAGE
"j" = 120/240VAC

THIS PAGE IS LEFT INTENTIONALLY BLANK

GROUP G

NOTES:

- 1) MINIMUM RECOMMENDED CONCRETE PAD SIZE: 1041 (41.0") WIDE X 1892 (74 1/2") LONG. REFERENCE INSTALLATION GUIDE SUPPLIED WITH UNIT FOR CONCRETE PAD GUIDELINES.
- 2) ALLOW SUFFICIENT ROOM ON ALL SIDES OF THE GENERATOR FOR MAINTENANCE AND SERVICING, THIS UNIT MUST BE INSTALLED IN ACCORDANCE WITH CURRENT APPLICABLE NFPA 37 AND NFPA 70 STANDARDS AS WELL AS ANY OTHER FEDERAL, STATE AND LOCAL CODES FOR MINIMUM DISTANCES FROM OTHER STRUCTURES.
- 3) CIRCUIT BREAKER INFORMATION:
SEE SPECIFICATION SHEET WITHIN OWNERS MANUAL.
- 4) INSIDE STUB-UP AREA FOR AC LOAD LEAD CONDUIT CONNECTION, NEUTRAL CONNECTION, BATTERY CHARGER 120 VOLT AC (0.5 AMP MAX.) CONNECTION, ACCESS TO TRANSFER SWITCH CONTROL WIRES, AND TRANSFER SWITCH CONNECTION (IF SO EQUIPPED). REMOVE FRONT COVER FOR ACCESS.
- 4A) ONE 1-1/2" NEMA ELECTRICAL KNOCKOUT AND TWO 1/2" NEMA ELECTRICAL KNOCKOUTS PROVIDED FOR OUTSIDE AC LOAD CONDUIT CONNECTION, NEUTRAL CONNECTION, BATTERY CHARGER 120 VOLT AC (0.5 AMP MAX.) CONNECTION, ACCESS TO TRANSFER SWITCH CONTROL WIRES, AND TRANSFER SWITCH CONNECTION (IF SO EQUIPPED). REMOVE FRONT COVER FOR ACCESS.
- 5) REFERENCE OWNERS MANUAL FOR LIFTING WARNINGS.
- 6) REMOVE LIFT-OFF ENCLOSURE TO ACCESS EXHAUST MUFFLER.

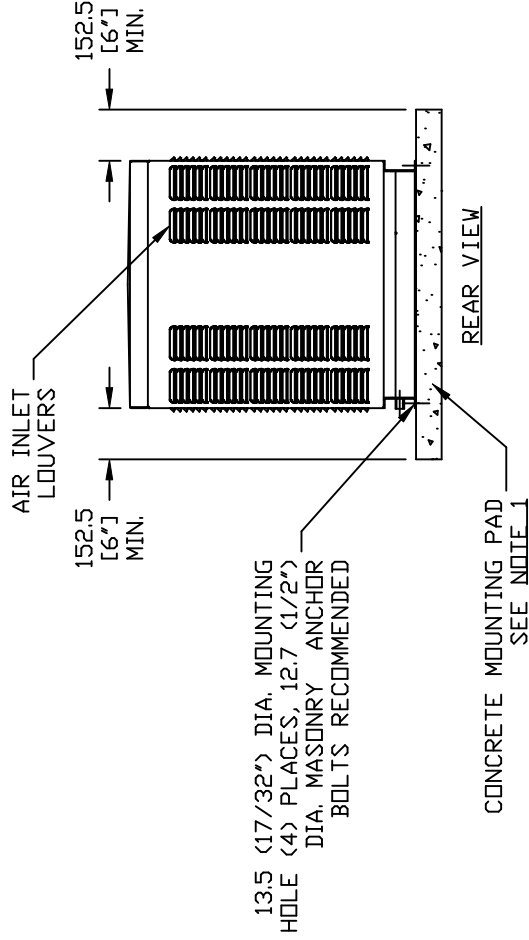

WEIGHT DATA				
ENGINE/KW	ENCLOSURE MATERIAL	WEIGHT (GENSET ONLY) KG [LBS]	WEIGHT (SHIPPING CARTON/SKID) KG [LBS]	SHIPPING WEIGHT (GENSET, SKID, & CARTON) KG [LBS]
2. 4L/22KW	ALUMINUM	383 [843]	30 [66]	413 [909]
2. 4L/27KW	ALUMINUM	405 [891]		434 [957]

EXPLODED VIEW:
INSTALLATION DRAWING C1 CPL
DRAWING #: 0G9370

GROUP G

SERVICE ITEM ACCESSIBILITY CHART

SERVICE ITEM	ACCESS
OIL FILL CAP	THRU RIGHT DOOR
OIL DIP STICK	THRU RIGHT DOOR
OIL FILTER	THRU RIGHT DOOR
OIL DRAIN HOSE	THRU LEFT DOOR
RADIATOR DRAIN HOSE	THRU LEFT DOOR
AIR CLEANER ELEMENT	THRU LEFT DOOR
SPARK PLUGS	THRU LEFT DOOR
MUFFLERS	SEE NOTE 6
FAN BELT	THRU RIGHT DOOR
BATTERY	THRU LEFT DOOR

REFERENCE OWNERS MANUAL
FOR PERIODIC REPLACEMENT
PART LISTINGS

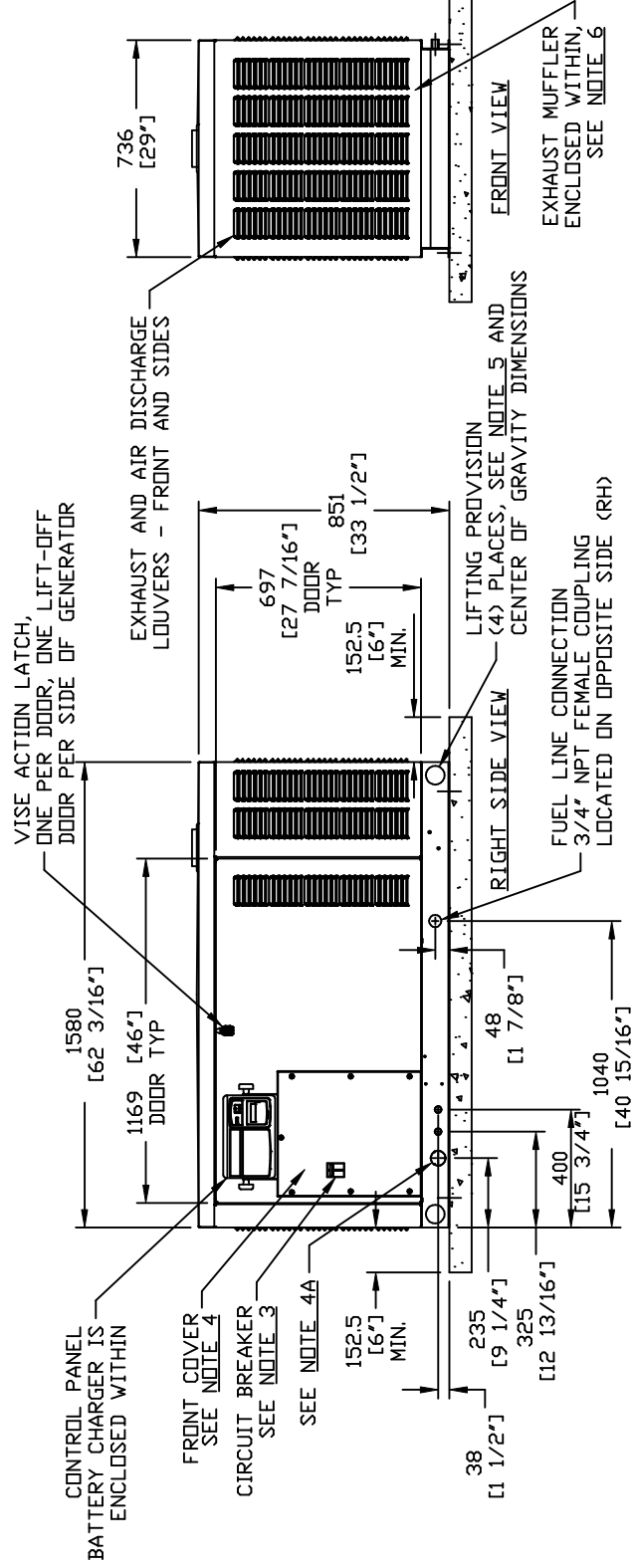
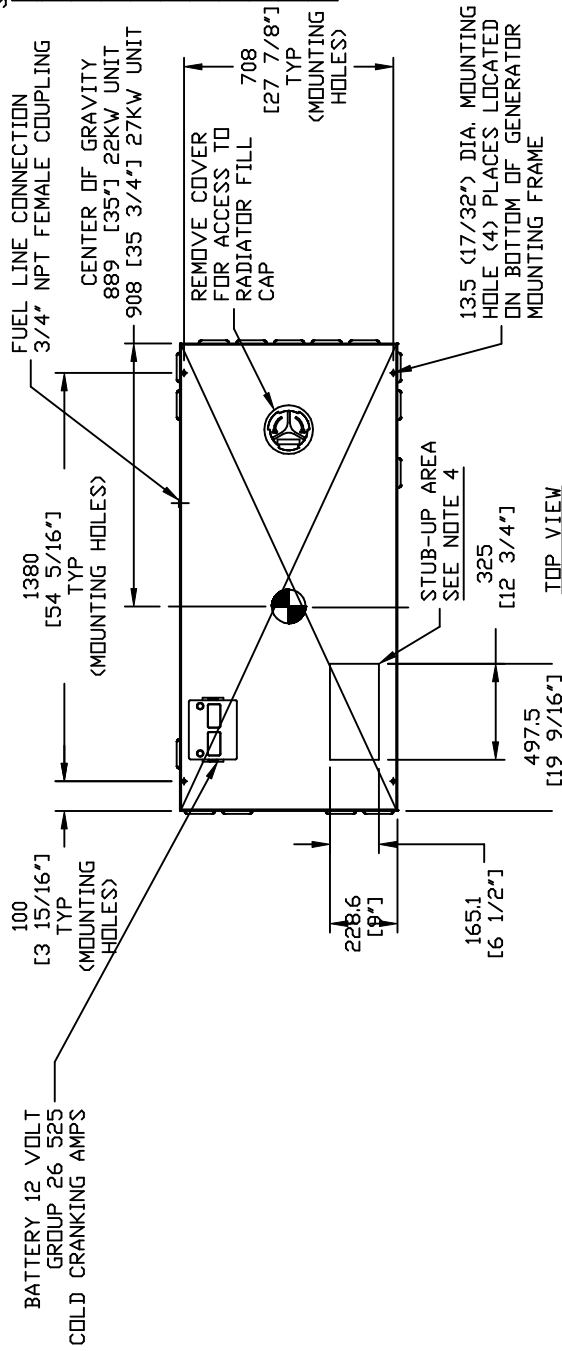

EXPLODED VIEW:
INSTALLATION DRAWING C1 CPL
DRAWING #: 0G9370

GROUP G

CONTROL PANEL LEGEND:
AVR - AUTOMATIC VOLTAGE REGULATOR
BCH - BATTERY CHARGER
BR1 - DIODE (FIELD BOOST)
CB2 - CIRCUIT BREAKER (EXCITATION)
CC - CROSSOVER CONNECTOR
F1 - FUSE, BAT POWER (15A ATO TYPE)
HM - HOUR METER
J2 - CONNECTOR 2 (ON PCB)
R4 - FIELD BOOST RESISTOR 15 OHM
RL1 - RELAY 1 (START RELAY)
RL2 - RELAY 2 (ENGINE RUN)
SW1 - AUTO/OFF/MANUAL SWITCH
SW2 - SET EXERCISER SWITCH
TB - TERMINAL BLOCK
TR1 - TRANSFORMER (6VA UTIL/16 VAC)

NOTE: ALL WIRES ARE 18 AWG
UL LISTED UNLESS OTHERWISE
NOTED AS SHOWN:



CUSTOMER CONNECTION & ALTERNATOR LEGEND:
BA - BRUSH ASSEMBLY (GENERATOR)
CB1 - MAINLINE CIRCUIT BREAKER
NB - NEUTRAL BLOCK
TB-BC - BATTERY CHARGER TERMINAL BLOCK
TBG - GTS CONNECT TERMINAL BLOCK
TBR - RTS CONNECT TERMINAL BLOCK

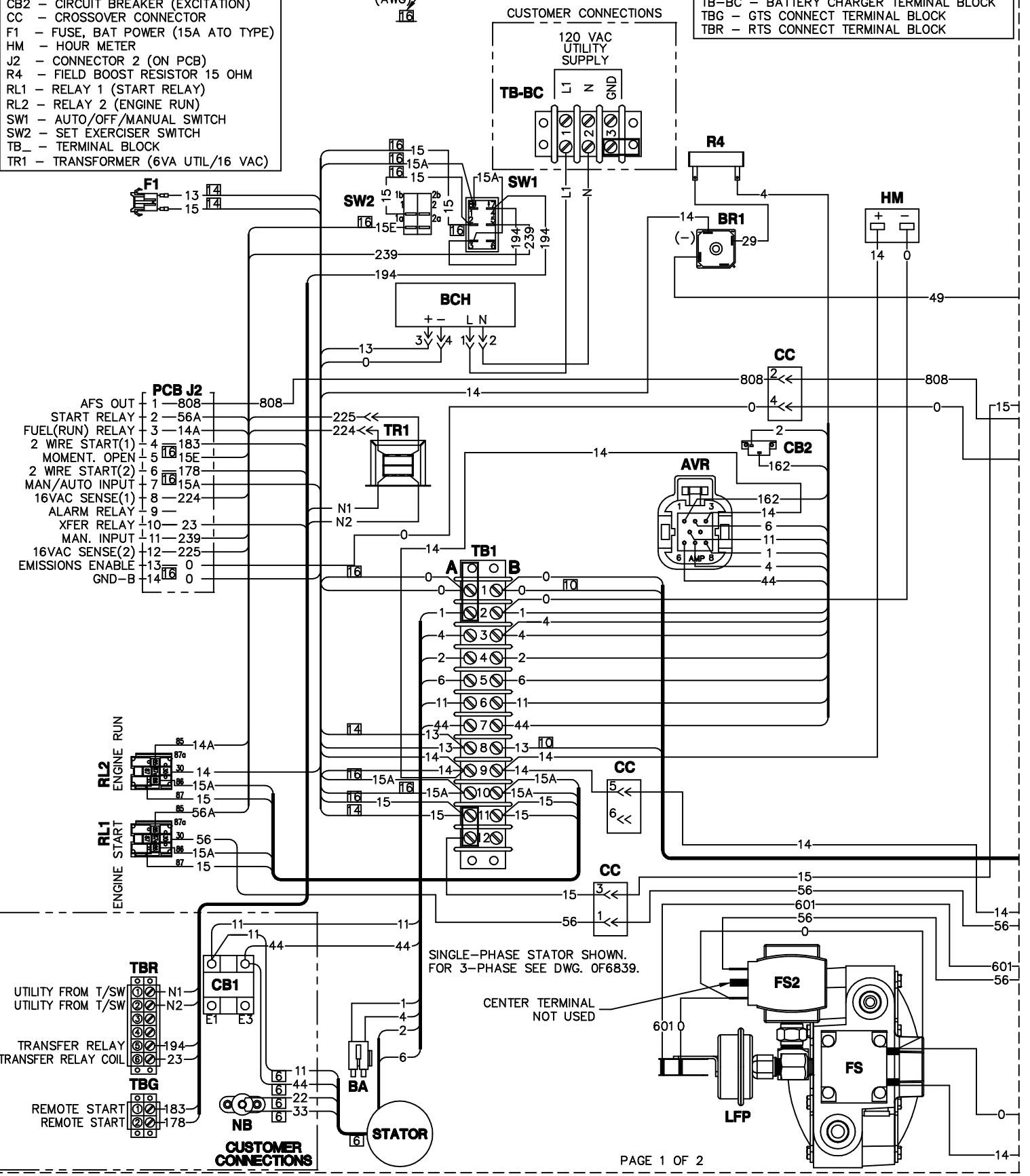

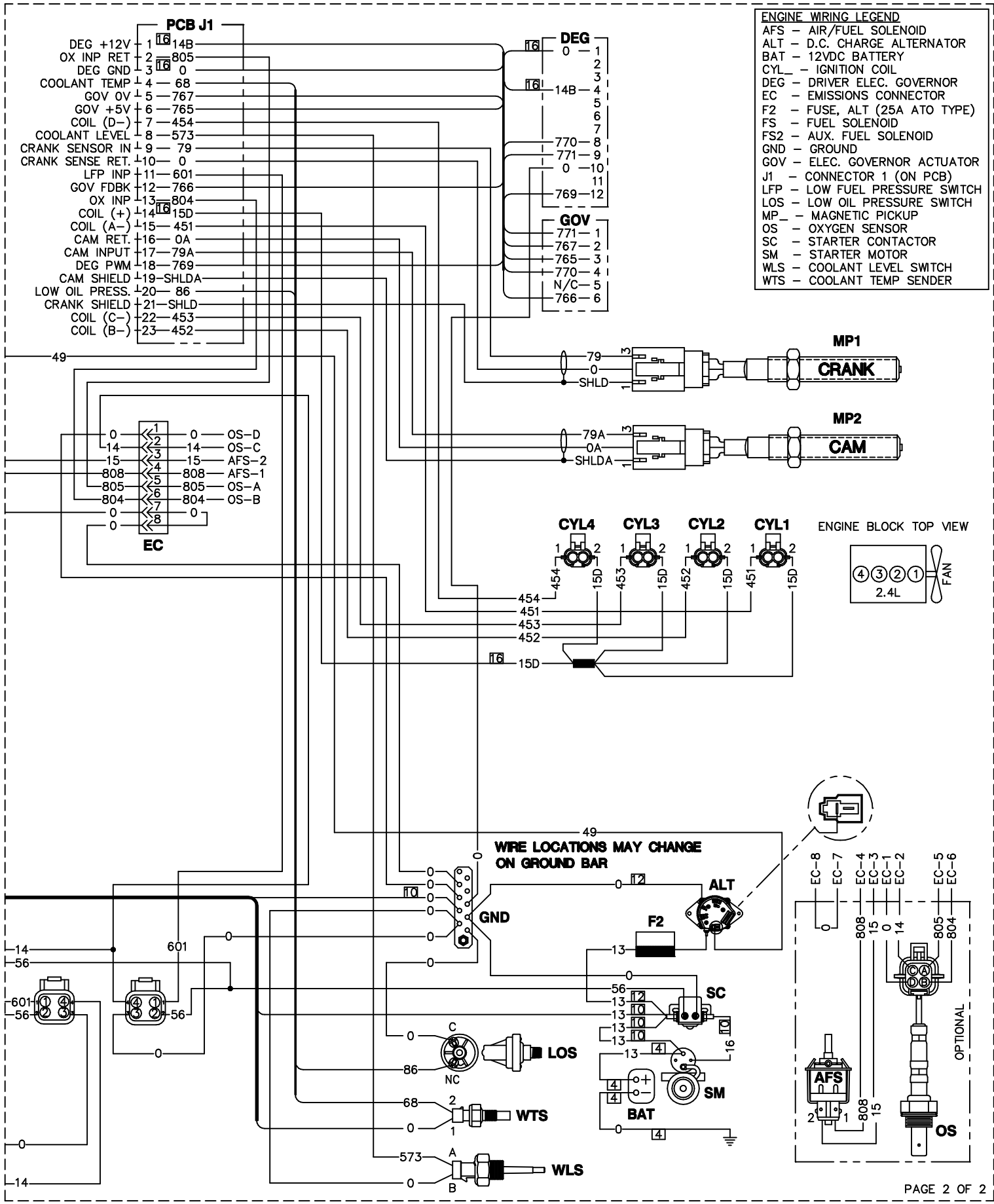

CONTROL PANEL LEGEND:

- AVR - AUTOMATIC VOLTAGE REGULATOR
- BCH - BATTERY CHARGER
- BR1 - DIODE (FIELD BOOST)
- CB2 - CIRCUIT BREAKER (EXCITATION)
- F1 - FUSE BAT POWER (15A ATO TYPE)
- HM - HOUR METER
- J2 - CONNECTOR 2 (ON PCB)
- R4 - FIELD BOOST RESISTOR 15 OHM
- RL1 - RELAY 1 (START RELAY)
- RL2 - RELAY 2 (ENGINE RUN)
- SW1 - AUTO/OFF/MANUAL SWITCH
- SW2 - SET EXERCISER SWITCH
- TR1 - TRANSFORMER (6VA UTIL/16 VAC)

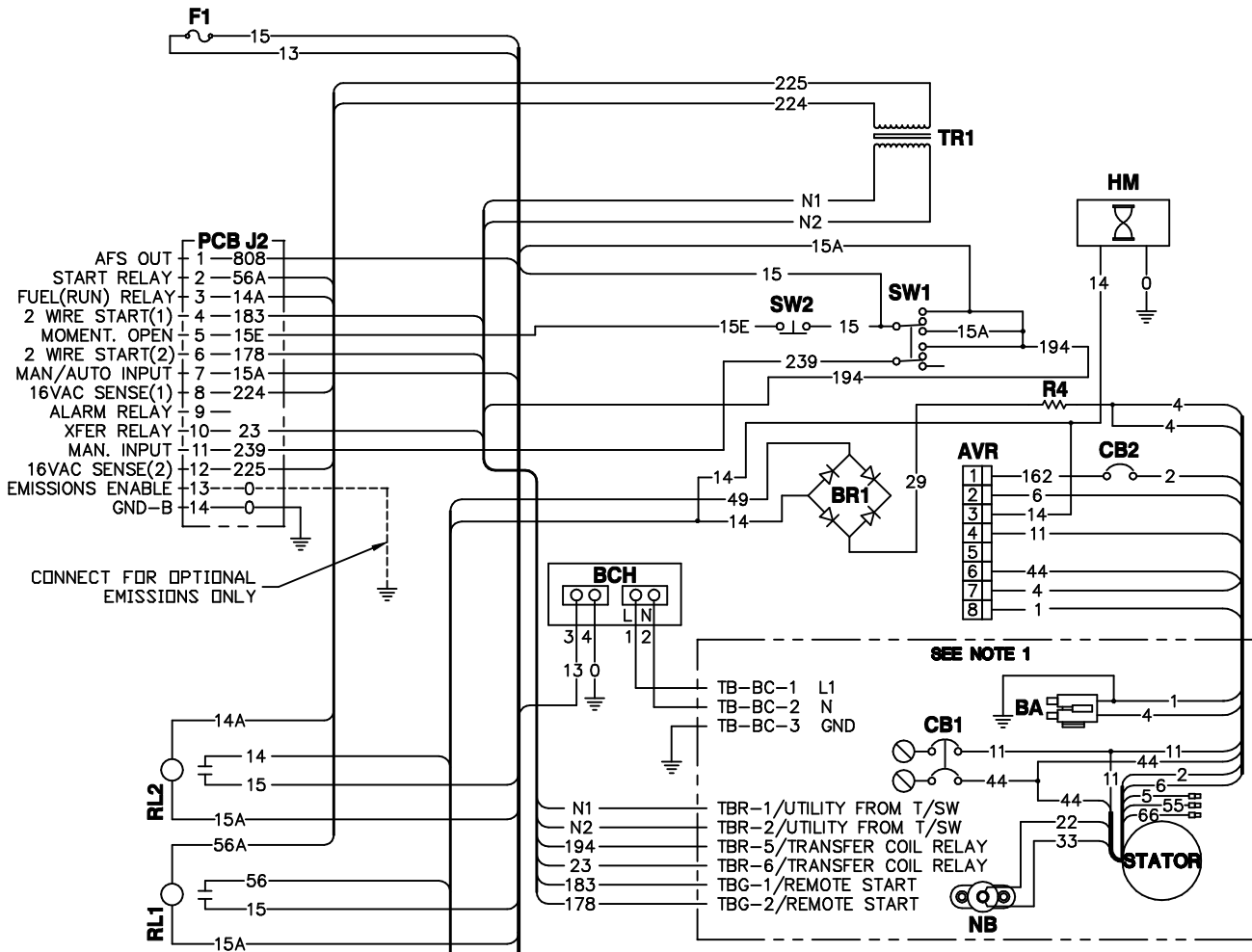

NOTE 1: WIRING SHOWN FOR CB1, NB, BA AND STATOR IS TYPICAL FOR SINGLE PHASE. FOR 3-PHASE, SEE DWG #0F6B39.

CUSTOMER CONNECTION & ALTERNATOR LEGEND:
 BA - BRUSH ASSEMBLY (GENERATOR)
 CB1 - MAINLINE CIRCUIT BREAKER
 NB - NEUTRAL BLOCK
 TB-BC - BATTERY CHARGER TERMINAL BLOCK
 TBG - GTS CONNECT TERMINAL BLOCK
 TBR - RTS CONNECT TERMINAL BLOCK

ENGINE WIRING LEGEND	
AFS	- AIR/FUEL SOLENOID
ALT	- D.C. CHARGE ALTERNATOR
BAT	- 12VDC BATTERY
CYL	- IGNITION COIL
DEG	- DRIVER ELEC. GOVERNOR
F2	- FUSE ALT (25A ATO TYPE)
FS	- FUEL SOLENOID
FS2	- AUX. FUEL SOLENOID
GOV	- ELEC. GOVERNOR ACTUATOR
J1	- CONNECTOR 1 (ON PCB)
LFP	- LOW FUEL PRESSURE SWITCH
LOS	- LOW OIL PRESSURE SWITCH
MP	- MAGNETIC PICKUP
OS	- OXYGEN SENSOR
SC	- STARTER CONTACTOR
SM	- STARTER MOTOR
SP	- SPARK PLUG
WLS	- COOLANT LEVEL SWITCH
WTS	- COOLANT TEMP SENDER

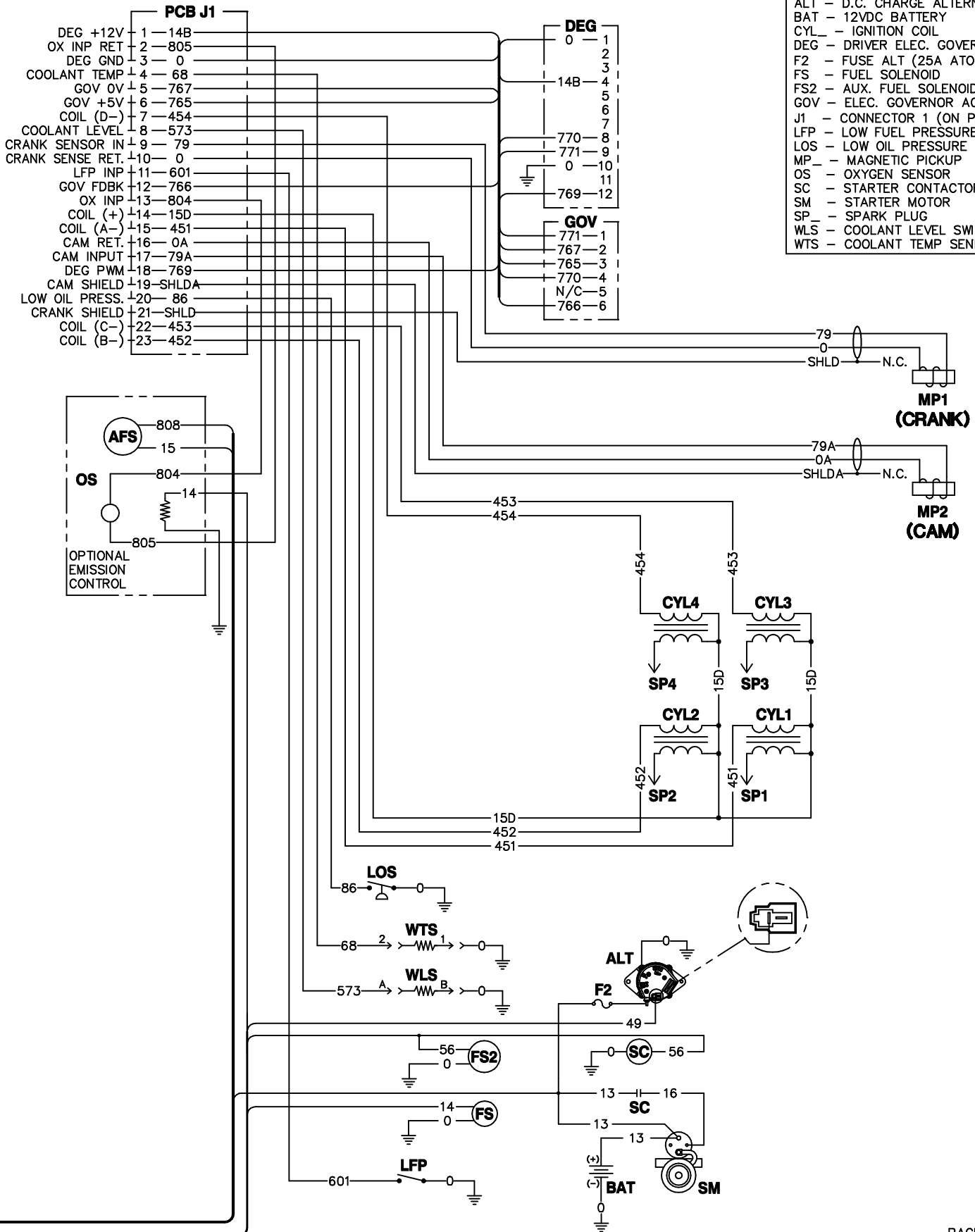

GROUP G

NOTE: ITEMS MARKED BY * ARE PART OF WIRE HARNESS.

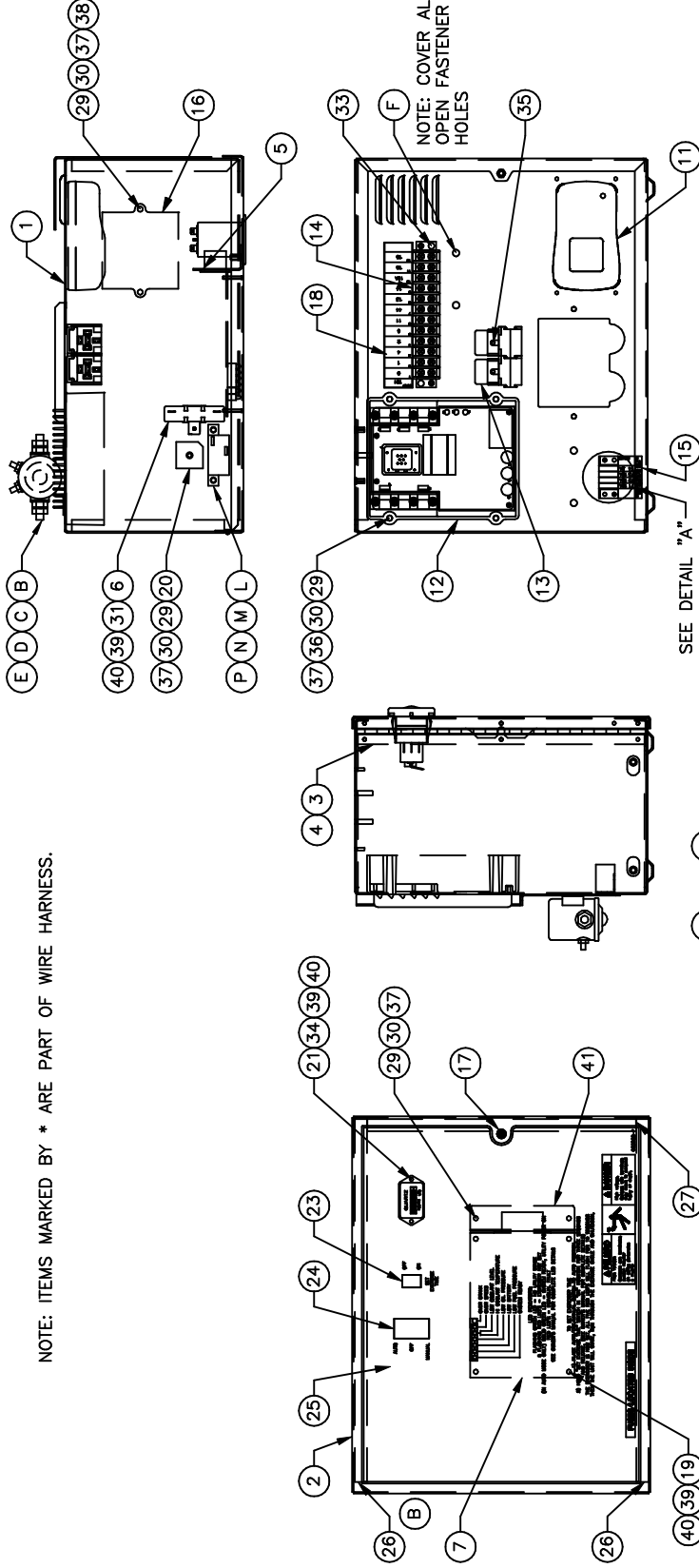

MODEL RATING	ITEM L RATING	ITEM L P/N
22KW/27KW 1φ	3A	054502
22KW/27KW 3φ	6A	048505
36KW 1φ/3φ	7A	048467
17.6KW/21.6KW 1φ 50Hz	5A	048512

EXPLODED VIEW:
R-200C 1800 RPM 2.4L
DRAWING #: 0H1433D

APPLICABLE TO:

ITEM	PART #	QTY.	DESCRIPTION
COMPONENTS INCLUDED IN 0H1433E			
1	0F1823B	1	ENCL HSB CONTROL PANEL
2	0F3078BST06	1	COVER CONTROL PANEL R-200B
3	0F2606	1	HINGE CONTINUOUS H-PANEL
4	036261	7	RIVET POP .125 X .275 SS
5	0E7358	4	SCREW PPH HI-LO #4-24 X 3/8
6	052777	1	WASHER FLAT M3
7	0H1176A	1	ASSY PCB R-200C CNTRL 1800 RPM
*8	0F1262	REF.	HOLDER FUSE WICKMANN 178.6150
*9	0F1263	REF.	ADPTR RH SIDE WICKMANN 178.6191
*10	0F1264	REF.	ADPTR LH SIDE WICKMANN 178.6192
11	0G8023A	1	BATC 13.4VDC 2.5A W/4POS PLUG
12	0G2885	1	ASSY PCB HI-PWR VOLTAGE RGLTR
13	0E6875A	2	RELAY 12VDC C FORM W/DIODE
*14	055911	REF.	BLOCK TERM 20A 12 X 6 X 1100V
15	0F5459	1	DECAL CPL CNT PNL FUSES
16	0E3161	1	ASSY PCB BOSCH GOV DRMR
17	0G3648	1	M5X0.8 CAPTIVE PANEL KNLD HD
18	0F5462	1	DECAL CPL 3.9L TB1
19	0A5062J	4	SPACER 9.5H 3.2 ID
20	029673	1	DIO BRIDGE 25A 600V
21	0C1457A	1	HOUR METER 10-80VDC
22	0F1958	1	PLATE HARNESS CLAMP
23	082573	1	SWITCH RKR DPST 125V SPD
24	0E4494	1	SWITCH RKR DPDT ON-OFF-ON
25	0G8997	1	DECAL CONTROL FLEX R-200B
26	0F6305	2	SEAL COVER 3.18X12.7X382
27	0F6305A	1	SEAL COVER 3.18X12.7X283
28	0F5886	2	SCREW HHPM M5-0.8 X 12
29	051713	11	WASHER FLAT M5
30	049226	11	WASHER LOCK M5
31	0F5752F	1	RES WW 15R 5% 25W QK CONN
32	0F5884	2	SCREW PHTT M3.5-0.6 X 10
33	0F5896	2	SCREW PHTT M3.5-0.6 X 16
34	074076	2	SCREW PHM M3-0.5 X 10 BLACK
35	0C3990	2	SCREW PHTT M4-0.7 X 10 ZYC
36	080823	4	SCREW PPHM M5-0.8 X 50 ZNC
37	051716	9	NUT HEX M5-0.8 G8 YEL CHR
38	079224	2	SCREW PPHM M5-0.8 X 30 SS
39	043182	7	WASHER LOCK M3
40	051714	7	NUT HEX M3-0.5 G8 YEL CHR
41	0F3192	1	SUPPORT ANGLE PCB
42	0E7403C	1	FUSE ATO TYPE 15 AMP (BLUE)
43	0G9056	1	HARN CTRL PNL R-200B 2.4L/4.2L (NOT SHOWN)
COMPONENTS INSTALLED PER THIS DRAWING			
A	056739	1	RELAY SOLENOID 12VDC PNL MNT
B	022287	2	SCREW HHC 1/4-20 X 3/4 G5
C	022473	4	WASHER FLAT 1/4-M6 ZINC
D	022097	2	WASHER LOCK M6-1/4
E	022127	2	NUT HEX 1/4-20 STEEL
F	0F6145	A/R	SEAL WEATHER .45"DIA
G	0F2627A	1	COVER CONTROL PANEL SIDE
H	091526	4	SCREW PPHM M5-0.8 X 12 ZNC
J	049226	4	WASHER LOCK M5
K	051713	4	WASHER FLAT M5
L	SEE CHART	1	DPE BREAKER
M	052777	2	WASHER FLAT M3
N	043182	2	WASHER LOCK M3
P	051714	2	NUT HEX M3-0.5 G8 YEL CHR

NOTE: ITEMS MARKED BY * ARE PART OF WIRE HARNESS.

Serial Number

**2.4L
22/27kW
Models
EPA Certified**

**STATIONARY EMERGENCY GENERATOR
OWNER'S MANUAL**

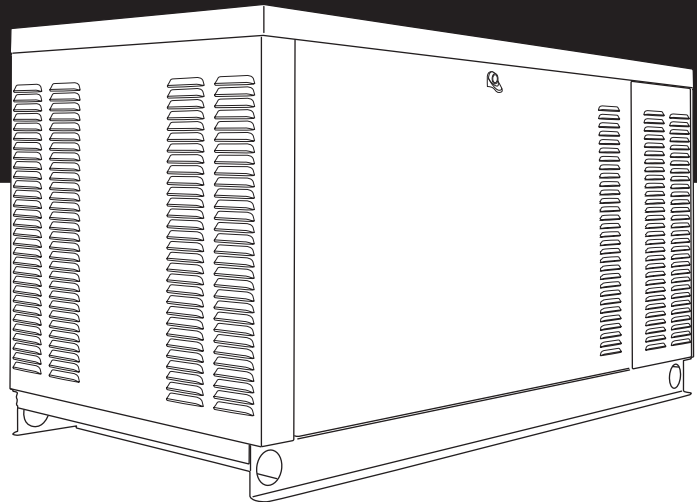

A new standard of reliability

⚠ Not intended for use in critical life support applications. ⚠



— ⚠ **CAUTION** ⚠ —

ONLY QUALIFIED ELECTRICIANS OR CONTRACTORS SHOULD ATTEMPT INSTALLATION!
DEADLY EXHAUST FUMES. OUTDOOR INSTALLATION ONLY!

This manual should remain with the unit.

SECTION	PAGE
INTRODUCTION	1-1
Read this Manual Thoroughly.....	1-1
Operation and Maintenance.....	1-1
How to Obtain Service.....	1-1
SAFETY RULES	1-2
IDENTIFICATION RECORD	2-1
Data Label.....	2-1
EQUIPMENT DESCRIPTION	3-1
Equipment Description.....	3-1
Engine Oil Recommendations.....	3-1
Coolant Recommendations.....	3-1
ENGINE PROTECTIVE DEVICES	4-1
Engine Protective Devices.....	4-1
High Coolant Temperature Switch.....	4-1
Low Coolant Level Sensor.....	4-1
Low Oil Pressure Switch.....	4-1
Overcrank Shutdown.....	4-1
Overspeed Shutdown.....	4-1
RPM Sensor Loss Shutdown.....	4-1
DC Fuses.....	4-1
FUEL SYSTEMS	5-1
Fuel Requirements.....	5-1
Natural Gas Fuel System.....	5-1
Propane Vapor Withdrawal Fuel System.....	5-1
LP Liquid Fuel System.....	5-1
SPECIFICATIONS	6-1
Stationary Emergency Generator.....	6-1
Engine.....	6-1
Cooling System.....	6-1
Fuel System.....	6-1
Electrical System.....	6-1
Cold Weather Kit.....	6-2
Coolant Heater Kit.....	6-2
Reconfiguring the Fuel System.....	6-2
Fuel System.....	6-2
Control Panel.....	6-3
GENERAL INFORMATION	7-1
Alternator AC Lead Connections.....	7-1
Four-lead, Single-phase Stator.....	7-1
Alternator Power Winding Connections.....	7-1
3-phase Alternators.....	7-1
INSTALLATION	8-1
Installation.....	8-1
Preparation Before Start-up.....	8-1
Transfer Switch.....	8-1
Fuel System.....	8-1
Generator Set Lubrication.....	8-1
Prior to Initial Start-up.....	8-1
Engine Coolant.....	8-1
Belt Tension.....	8-1
Electrical System.....	8-1
Initial Inspection for Genset Start-up.....	8-1
Start-up Checklist.....	8-2
Preparation for Start-up.....	8-2
OPERATION	9-1
Stationary Emergency Generator Control and Operation.....	9-1
Operating Unit with Manual Transfer Switch.....	9-1
Engine Start-up and Transfer.....	9-1
Retransfer and Shutdown.....	9-1
Operating Unit with Automatic Transfer Switch.....	9-1
MAINTENANCE	10-1
Maintenance Performed by Service Dealers/Contractors.....	10-1
Every Three Months.....	10-1
Once Every Six Months.....	10-1
Once Annually.....	10-1
First 30 Operating Hours.....	10-1
First 100 Operating Hours.....	10-1
Every 500 Operating Hours.....	10-1
Cooling System.....	10-1
Overload Protection for Engine DC Electrical System.....	10-1
Checking Fluid Levels.....	10-1
Check Engine Oil.....	10-1
Battery Fluid.....	10-2
Engine Coolant.....	10-2
Maintenance Owner/Operator Can Perform.....	10-2
Check Engine Oil Level.....	10-2
Check Battery.....	10-2
Exercise System.....	10-2
Inspect Cooling System.....	10-2
Check Engine Coolant Level.....	10-2
Perform Visual Inspection.....	10-2
Inspect Exhaust System.....	10-2
Check Fan Belt.....	10-2
Inspect Engine Governor.....	10-3
Changing Engine Oil.....	10-3
Changing the Engine Air Filter.....	10-3
Spark Plugs.....	10-4
Coolant Change.....	10-4
Miscellaneous Maintenance.....	10-4
Cleaning the Stationary Emergency Generator.....	10-4
Battery.....	10-4
Battery Maintenance.....	10-4
Battery Replacement.....	10-5
Repair Parts.....	10-5
SERVICE SCHEDULE	11-1
TROUBLESHOOTING	12-1
Troubleshooting Guide.....	12-1
EMISSIONS WARRANTY	13-1
NOTES	
EXPLODED VIEWS & PARTS LISTS	
WIRING DIAGRAMS & SCHEMATICS	



 **SAVE THESE INSTRUCTIONS** – The manufacturer suggests that these rules for safe operation be copied and posted in potential hazard areas. Safety should be stressed to all operators, potential operators, and service and repair technicians  for this equipment.

INTRODUCTION

Thank you for purchasing this model of the stationary emergency generator product line.

Every effort was expended to make sure that the information and instructions in this manual were both accurate and current at the time the manual was written. However, the manufacturer reserves the right to change, alter or otherwise improve this product(s) at any time without prior notice.

◆ READ THIS MANUAL THOROUGHLY

If any portion of this manual is not understood, contact the nearest Service Dealer for starting, operating and servicing procedures.

Throughout this publication, and on tags and decals affixed to the generator, DANGER, WARNING, CAUTION and NOTE blocks are used to alert personnel to special instructions about a particular service or operation that may be hazardous if performed incorrectly or carelessly. Observe them carefully. Their definitions are as follows:



After this heading, read instructions that, if not strictly complied with, will result in serious personal injury, including death, or property damage.



After this heading, read instructions that, if not strictly complied with, may result in personal injury or property damage.



After this heading, read instructions that, if not strictly complied with, could result in damage to equipment and/or property.

NOTE:

After this heading, read explanatory statements that require special emphasis.

These safety warnings cannot eliminate the hazards that they indicate. Common sense and strict compliance with the special instructions while performing the service are essential to preventing accidents.

Four commonly used safety symbols accompany the DANGER, WARNING and CAUTION blocks. The type of information each indicates is as follows:

 This symbol points out important safety information that, if not followed, could endanger personal safety and/or property of others.

 This symbol points out potential explosion hazard.

 This symbol points out potential fire hazard.

 This symbol points out potential electrical shock hazard.

The operator is responsible for proper and safe use of the equipment. The manufacturer strongly recommends that the operator read this Owner's Manual and thoroughly understand all instructions before using this equipment. The manufacturer also strongly recommends instructing other users to properly start and operate the unit. This prepares them if they need to operate the equipment in an emergency.

For safety reasons, the manufacturer recommends that this equipment be installed, serviced and repaired by a Service Dealer or other competent, qualified electrician or installation technician who is familiar with applicable codes, standards and regulations. The operator also must comply with all such codes, standards and regulations.

◆ OPERATION AND MAINTENANCE

It is the operator's responsibility to perform all safety checks, to make sure that all maintenance for safe operation is performed promptly, and to have the equipment checked periodically by a Service Dealer. Normal maintenance service and replacement of parts are the responsibility of the owner/operator and, as such, are not considered defects in materials or workmanship within the terms of the warranty. Individual operating habits and usage contribute to the need for maintenance service.

Proper maintenance and care of the generator ensure a minimum number of problems and keep operating expenses at a minimum. See a Service Dealer for service aids and accessories.

Operating instructions presented in this manual assume that the generator electric system has been installed by a Service Dealer or other competent, qualified contractor. Installation of this equipment is not a "do-it-yourself" project.

◆ HOW TO OBTAIN SERVICE

When the generator requires servicing or repairs, simply contact a Service Dealer for assistance. Service technicians are factory-trained and are capable of handling all service needs.

When contacting a dealer about parts and service, always supply the complete Model Number, Serial Number and Type Code (where applicable) from the DATA LABEL that is affixed to the unit.



WARNING:



The engine exhaust from this product contains chemicals known to the state of California to cause cancer, birth defects or other reproductive harm.



WARNING:



This product contains or emits chemicals known to the state of California to cause cancer, birth defects or other reproductive harm.

Study these SAFETY RULES carefully before installing, operating or servicing this equipment. Become familiar with this Owner's Manual and with the unit. The generator can operate safely, efficiently and reliably only if it is properly installed, operated and maintained. Many accidents are caused by failing to follow simple and fundamental rules or precautions.

The manufacturer cannot anticipate every possible circumstance that might involve a hazard. The warnings in this manual, and on tags and decals affixed to the unit are, therefore, not all inclusive. If a procedure, work method or operating technique is used that the manufacturer does not specifically recommend, ensure that it is safe for others. Also make sure the procedure, work method or operating technique utilized does not render the generator unsafe.

— **DANGER** —

Despite the safe design of this generator, operating this equipment imprudently, neglecting its maintenance or being careless can cause possible injury or death. Permit only responsible and capable persons to install, operate or maintain this equipment.

Potentially lethal voltages are generated by these machines. Ensure all steps are taken to render the machine safe before attempting to work on the generator.

Parts of the generator are rotating and/or hot during operation. Exercise care near running generators.

GENERAL HAZARDS

- For safety reasons, the manufacturer recommends that this equipment be installed, serviced and repaired by a Service Dealer or other competent, qualified electrician or installation technician who is familiar with applicable codes, standards and regulations. The operator also must comply with all such codes, standards and regulations.
- Installation, operation, servicing and repair of this (and related) equipment must always comply with applicable codes, standards, laws and regulations. Adhere strictly to local, state and national electrical and building codes. Comply with regulations the Occupational Safety and Health Administration (OSHA) has established. Also, ensure that the generator is installed, operated and serviced in accordance with the manufacturer's instructions and recommendations. Following installation, do nothing that might render the unit unsafe or in noncompliance with the aforementioned codes, standards, laws and regulations.
- The engine exhaust fumes contain carbon monoxide gas, which can be DEADLY. This dangerous gas, if breathed in sufficient concentrations, can cause unconsciousness or even death. For that reason, adequate ventilation must be provided. This should be considered prior to installing the generator. The unit should be positioned to direct exhaust gasses safely away from any building where people, animals, etc., will not be harmed. Any exhaust stacks that ship loose with the unit must be installed properly per the manufacturer's instruction, and in strict compliance with applicable codes and standards.
- Keep hands, feet, clothing, etc., away from drive belts, fans, and other moving or hot parts. Never remove any drive belt or fan guard while the unit is operating.
- Adequate, unobstructed flow of cooling and ventilating air is critical in any room or building housing the generator to prevent buildup of explosive gases and to ensure correct generator operation. Do not alter the installation or permit even partial blockage of ventilation provisions, as this can seriously affect safe operation of the generator.
- Keep the area around the generator clean and uncluttered. Remove any materials that could become hazardous.
- When working on this equipment, remain alert at all times. Never work on the equipment when physically or mentally fatigued.
- Inspect the generator regularly, and promptly repair or replace all worn, damaged or defective parts using only factory-approved parts.
- Before performing any maintenance on the generator, disconnect its battery cables to prevent accidental start-up. Disconnect the cable from the battery post indicated by a NEGATIVE, NEG or (-) first. Reconnect that cable last.
- Never use the generator or any of its parts as a step. Stepping on the unit can stress and break parts, and may result in dangerous operating conditions from leaking exhaust gases, fuel leakage, oil leakage, etc.



ELECTRICAL HAZARDS

- All stationary emergency generators covered by this manual produce dangerous electrical voltages and can cause fatal electrical shock. Utility power delivers extremely high and dangerous voltages to the transfer switch as well as the generator. Avoid contact with bare wires, terminals, connections, etc., on the generator as well as the transfer switch, if applicable. Ensure all appropriate covers, guards and barriers are in place before operating the generator. If work must be done around an operating unit, stand on an insulated, dry surface to reduce shock hazard.
- Do not handle any kind of electrical device while standing in water, while barefoot, or while hands or feet are wet. DANGEROUS ELECTRICAL SHOCK MAY RESULT.
- If personnel must stand on metal or concrete while installing, operating, servicing, adjusting or repairing this equipment, place insulative mats over a dry wooden platform. Work on the equipment only while standing on such insulative mats.
- The National Electrical Code (NEC) requires the frame and external electrically conductive parts of the generator to be connected to an approved earth ground. This grounding will help prevent dangerous electrical shock that might be caused by a ground fault condition in the generator or by static electricity. Never disconnect the ground wire.
- Wire gauge sizes of electrical wiring, cables and cord sets must be adequate to handle the maximum electrical current (ampacity) to which they will be subjected.
- Before installing or servicing this (and related) equipment, make sure that all power voltage supplies are positively turned off at their source. Failure to do so will result in hazardous and possibly fatal electrical shock.
- Connecting this unit to an electrical system normally supplied by an electric utility shall be by means of a transfer switch so as to isolate the generator electric system from the electric utility distribution system when the generator is operating. Failure to isolate the two electric system power sources from each other by such means will result in damage to the generator and may also result in injury or death to utility power workers due to backfeed of electrical energy.
- Stationary emergency generators installed with an automatic transfer switch will crank and start automatically when normal (utility) source voltage is removed or is below an acceptable preset level. To prevent such automatic start-up and possible injury to personnel, disable the generator's automatic start circuit (battery cables, etc.) before working on or around the unit. Then, place a "Do Not Operate" tag on the generator control panel and on the transfer switch.
- In case of accident caused by electric shock, immediately shut down the source of electrical power. If this is not possible, attempt to free the victim from the live conductor. AVOID DIRECT CONTACT WITH THE VICTIM. Use a nonconducting implement, such as a dry rope or board, to free the victim from the live conductor. If the victim is unconscious, apply first aid and get immediate medical help.
- Never wear jewelry when working on this equipment. Jewelry can conduct electricity resulting in electric shock, or may get caught in moving components causing injury.

FIRE HAZARDS

- Keep a fire extinguisher near the generator at all times. Do NOT use any carbon tetra-chloride type extinguisher. Its fumes are toxic, and the liquid can deteriorate wiring insulation. Keep the extinguisher properly charged and be familiar with its use. If there are any questions pertaining to fire extinguishers, consult the local fire department.

EXPLOSION HAZARDS

- Properly ventilate any room or building housing the generator to prevent build-up of explosive gas.
- Do not smoke around the generator. Wipe up any fuel or oil spills immediately. Ensure that no combustible materials are left in the generator compartment, or on or near the generator, as FIRE or EXPLOSION may result. Keep the area surrounding the generator clean and free from debris.
- These generators may operate using one of several types of fuels. All fuel types are potentially FLAMMABLE and/or EXPLOSIVE and should be handled with care. Comply with all laws regulating the storage and handling of fuels. Inspect the unit's fuel system frequently and correct any leaks immediately. Fuel supply lines must be properly installed, purged and leak tested according to applicable fuel-gas codes before placing this equipment into service.
- Diesel fuels are highly FLAMMABLE. Gaseous fluids such as natural gas and liquid propane (LP) gas are extremely EXPLOSIVE. Natural gas is lighter than air, and LP gas is heavier than air; install leak detectors accordingly.

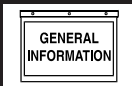

Stationary Emergency Generator General Information

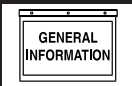

IDENTIFICATION RECORD

◆ DATA LABEL

Every generator set has a DATA LABEL that contains important information pertinent to the generator. The data label, which can be found attached to the generator's lower connection box, lists the unit's serial number and its rated voltage, amps, wattage capacity, phase, frequency, rpm, power factor, production date, etc.

NOTE:

For actual information related to this particular model, please refer to the Manual Drawing Listing located at the end of this manual, or to the data label affixed to the unit.

★ *Stationary Emergency Generator Model and Serial Number*

This number is the key to numerous engineering and manufacturing details pertaining to your unit. Always supply this number when requesting service, ordering parts or seeking information.

Data Label

MODEL	<input type="text"/>	<input type="text"/>
PROD DATE	<input type="text"/>	SERIAL <input type="text"/>
KW <input type="text"/>	KVA <input type="text"/>	PHASE <input type="text"/>
HERTZ <input type="text"/>	VOLT <input type="text"/>	AMP <input type="text"/>
PWR FACT <input type="text"/>	ALT RPM <input type="text"/>	ENG RPM <input type="text"/>
TYPE CODE <input type="text"/>	ALT SUBTRANS REACTANCE <input type="text"/>	ALT TRANS REACTANCE <input type="text"/>
CLASS <input type="checkbox"/> ROTOR <input type="checkbox"/> STATOR WINDING INS AT 25°C AMB		
<input type="text"/>		<input type="text"/>
MODEL NO (CAT/CUST NO)	SERIAL NO	
<input type="text"/>	<input type="text"/>	
<input type="text"/>		<input type="text"/>

0G2110 REV C

Equipment Description

EQUIPMENT DESCRIPTION

This equipment is a revolving field, alternating current Stationary Emergency Generator set. It is powered by a gaseous fueled engine operating at 1800 rpm for 4-pole direct drive units, 3600 rpm for 2-pole direct drive units and 2300 - 3000 rpm for quiet drive gear units. See the Specifications section for exact numbers. The unit comes complete with a sound attenuated enclosure, internally mounted muffler, control console, mainline circuit breaker, battery charger, and protective alarms as explained in the following paragraph.

All AC connections, including the power leads from the alternator, 120 volt battery charger input and control connections to the transfer switch are available in the main connection box.

The Stationary Emergency Generator incorporates the following generator features:

- Rotor and Stator insulation is Class H rated as defined by NEMA MG1-32.6, MG1-1.66. The generator is self ventilated and drip-proof constructed.
- The voltage waveform deviation, total harmonic content of the AC waveform and telephone influence factor have been evaluated and are acceptable according to NEMA MG1-32.

ENGINE OIL RECOMMENDATIONS

The unit has been filled with 5W-20 engine oil at the factory. Use a high-quality detergent oil classified "For Service SJ or SH." Detergent oils keep the engine cleaner and reduce carbon deposits. When changing the engine oil, be sure to use 5W-30 engine oil (synthetic oil is recommended).

⚠ CAUTION!

- ⚠ Any attempt to crank or start the engine before it has been properly serviced with the recommended oil may result in an engine failure.

NOTE:

For temperatures below 32° F, it is strongly recommended to use the optional Cold Weather Start Kit. The oil grade for temperatures below 32° F is 5W-30 synthetic oil.

COOLANT RECOMMENDATIONS

Use a mixture of half low silicate ethylene glycol base anti-freeze and deionized water. Cooling system capacity is listed in the specifications. Use only deionized water and only low silicate anti-freeze. If desired, add a high quality rust inhibitor to the recommended coolant mixture. When adding coolant, always add the recommended 50-50 mixture.

⚠ CAUTION!

- ⚠ Do not use any chromate base rust inhibitor with ethylene glycol base anti-freeze or chromium hydroxide ("green slime") forms and will cause overheating. Engines that have been operated with a chromate base rust inhibitor must be chemically cleaned before adding ethylene glycol base anti-freeze. Using any high silicate anti-freeze boosters or additives will also cause overheating. The manufacturer also recommends that any soluble oil inhibitor is NOT used for this equipment.

⚠ DANGER!

- ⚠ Do not remove the radiator pressure cap while the engine is hot or serious burns from boiling liquid or steam could result.
- ⚠ Ethylene glycol base antifreeze is poisonous. Do not use mouth to siphon coolant from the radiator, recovery bottle or any container. Wash hands thoroughly after handling. Never store used antifreeze in an open container because animals are attracted to the smell and taste of antifreeze even though it is poisonous to them.

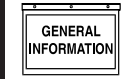
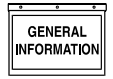

ENGINE PROTECTIVE DEVICES

The Stationary Emergency Generator may be required to operate for long periods of time without an operator on hand to monitor such engine conditions as coolant temperature, oil pressure or rpm. For that reason, the engine has several devices designed to protect it against potentially damaging conditions by automatically shutting down the unit when the oil pressure is too low, the coolant temperature is too high, the coolant level is too low, or the engine is running too fast.

NOTE:

Engine protective switches and sensors are mentioned here for the reader's convenience. Also refer to the applicable control panel manual for additional automatic engine shutdown information.

◆ HIGH COOLANT TEMPERATURE SWITCH

The switch will close if the temperature should exceed approximately 140° C (284° F), initiating an engine shutdown. The generator will automatically restart and the LED will reset once the temperature has returned to a safe operating level.

◆ LOW COOLANT LEVEL SENSOR

To prevent overheating, the engine has a low coolant level sensor. If the level of engine coolant drops below the level of the low coolant level sensor, the engine automatically shuts down.

◆ LOW OIL PRESSURE SWITCH

This switch has normally closed contacts that are held open by engine oil pressure during cranking and operating. Should oil pressure drop below the 8 psi range, switch contacts close, and the engine shuts down. The unit should not be restarted until oil is added, and the AUTO/OFF/MANUAL switch must be turned to OFF and then back to AUTO.

◆ OVERCRANK SHUTDOWN

After a prespecified duration of cranking, this function ends the cranking if the engine has failed to start. The overcrank LED will turn ON. Turn OFF the AUTO/OFF/MANUAL switch, then turn switch back to AUTO to reset the generator control board.

NOTE:

If the fault is not corrected, the overcrank feature will continue to activate.

Approximate Crank Cycle Times

- 15 seconds ON
 - 7 seconds OFF
 - 7 seconds ON
 - 7 seconds OFF
 - Repeat for 45 seconds
- Approximately 90 seconds total.

◆ OVERSPEED SHUTDOWN

A speed circuit controls engine cranking, start-up, operation and shutdown. Engine speed signals are delivered to the circuit board whenever the unit is running. Should the engine overspeed above a safe, preset value, the circuit board initiates an automatic engine shutdown. Contact the nearest Authorized Dealer if this failure occurs.

◆ RPM SENSOR LOSS SHUTDOWN

If the speed signal to the control panel is lost, engine shutdown will occur.

◆ DC FUSES

Fuse F1 (15 amp) is located inside of the control panel. It protects the panel wiring and components from damaging overload. **Always remove this fuse before commencing work on the generator.** The unit will not start or crank if the fuse is blown.

Fuse F2 (25 amp) is located in the engine wire harness adjacent to the DC alternator. It is used to prevent circuit failure due to DC alternator failure. If this fuse is blown, battery charging will not occur while the engine is running. Replace these fuses with the same size, type, and rating. (See the exploded views and parts lists at the end of this manual for replacement part number.)

FUEL SYSTEM

FUEL REQUIREMENTS

The Stationary Emergency Generator may be equipped with one of the following fuel systems:

- Natural gas fuel system
- Propane vapor (LPV) fuel system

Recommended fuels should have a Btu content of at least 1,000 Btu's per cubic foot for natural gas; or at least 2,520 Btu's per cubic foot for LP gas. Ask the fuel supplier for the Btu content of the fuel.

NOTE:

The fuel consumption requirements are identified in the Specifications section of the Owner's Manual. Refer to the Installation Manual if assistance is required for the sizing of the pipe diameter for the generator. Any piping used to connect the generator to the fuel supply should be of adequate size to achieve the 100% load fuel consumption requirements identified in the Specifications section regardless of actual load.

NOTE:

The recommended fuel pressure is identified in the Specifications section this manual.

NOTE:

It is the responsibility of the installer to make sure that only the correct recommended fuel is supplied to the generator fuel system. Thereafter, the owner/operator must make certain that only the proper fuel is supplied.

NATURAL GAS FUEL SYSTEM

Natural gas is supplied in its vapor state. In most cases, the gas distribution company provides piping from the main gas distribution line to the standby generator site. The following information applies to natural gas fuel systems.

- Gas pressure in a building is usually regulated by national, state and local codes.
- To reduce gas pressure to a safe level before the gas enters a building, a primary regulator is needed. The natural gas supplier may or may not supply such a regulator.
- It is the responsibility of the gas supplier to make sure sufficient gas pressure is available to operate the primary regulator.
- Gas pressure at the inlet to the fuel shutoff solenoid must never exceed approximately 14 inches water column (0.5 psi).

PROPANE VAPOR WITHDRAWAL FUEL SYSTEM

This type of system utilizes the vapors formed above the liquid fuel in the supply tank. Approximately 10 to 20 percent of the tank capacity is needed for fuel expansion from the liquid to the vapor state. The vapor withdrawal system is generally best suited for smaller engines that require less fuel. The installer should be aware of the following:

- When ambient temperatures are low and engine fuel consumption is high, the vapor withdrawal system may not function efficiently.
- Ambient temperatures around the supply tank must be high enough to sustain adequate vaporization, or the system will not deliver the needed fuel volume.
- In addition to the cooling effects of ambient air, the vaporization process itself provides an additional cooling effect.

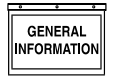

Stationary Emergency Generator Specifications



SPECIFICATIONS

◆ STATIONARY EMERGENCY GENERATOR

Type.....Synchronous
 Rotor Insulation..... Class H
 Stator Insulation..... Class H
 Total Harmonic Distortion..... < 5%
 Telephone Interference Factor (TIF) < 50
 Alternator Output Leads 3-phase 4-wire
 Bearings Sealed Ball
 Coupling Flexible Disc
 Load Capacity (Standby Rating) 22/27kW*

* NOTE: Generator rating and performance in accordance with ISO8528-5, BS5514, SAE J1349, ISO3046 and DIN 6271 Standards. KW rating is based on LPG fuel and may derate with natural gas and generator specific settings.

Excitation System	Direct		
Generator Output Voltage/kW - 60 Hz	<u>kW</u>	<u>Amp</u>	<u>CB Size</u>
120/240V, 1-phase, 1.0 pf	22/27	92/113	100/125
120/208V, 3-phase, 0.8 pf	22/27	77/94	80/100
120/240V, 3-phase, 0.8 pf	22/27	66/81	80/90
Generator Locked Rotor KVA Available @ Voltage Dip of 35%			
	<u>22kW</u>	<u>27kW</u>	
	38 KVA	42 KVA	

◆ ENGINE

Make Generac
 Model In Line
 Cylinders and Arrangement 4
 Displacement 2.4 Liter
 Bore..... 86.5 mm (3.41 in.)
 Stroke..... 100 mm (3.94 in.)
 Compression Ratio..... 9.5-to-1
 Air Intake System..... Naturally Aspirated
 Valve Seats Hardened
 Lifter Type..... Hydraulic

Engine Parameters

Rated Synchronous RPM 60 Hz, 1800
 HP at rated kW (22/27kW) 60 Hz, 32-36/38-43

Exhaust System

Exhaust Flow at Rated Output 60 Hz (22/27kW) 165/180 cfm
 Exhaust Temp. at Rated Output (22/27kW) 900°/1000° F

Combustion Air Requirements (Natural Gas)

Flow at rated power, 60 Hz..... 68 cfm

Governor

Type..... Electronic
 Frequency Regulation..... Isochronous
 Steady State Regulation ± 0.25%

Engine Lubrication System

Type of Oil Pump Gear
 Oil Filter Full Flow Spin-on, Cartridge
 Crankcase Oil Capacity 5.25 U.S. qts.
 (including oil filter capacity)

◆ COOLING SYSTEM

Type..... Pressurized Closed Recovery
 Water Pump..... Belt Driven
 Fan Speed..... 1980 rpm
 Fan Diameter..... 18.1 inches
 Fan Mode..... Pusher
 Air Flow (inlet air including alternator and combustion air) 2400 ft³/min.
 Coolant Capacity..... (3.0 U.S. gal.)
 Heat Rejection to Coolant (22/27kW) 99,000/105,000 Btu/h
 Maximum Operating Air Temp. on Radiator..... 60° C (150° F)
 Maximum Ambient Temperature 50° C (140° F)

◆ FUEL SYSTEM

Type of Fuel Natural Gas, Propane Vapor
 Carburetor..... Down Draft
 Secondary Fuel Regulator..... Standard
 Fuel Shut-off Solenoid..... Standard
 Operating Fuel Pressure 5 in. - 14 in. Water Column

Fuel Consumption - ft³/hr (Natural Gas/LPV)

	<i>Exercise</i>	<i>25%</i>	<i>50%</i>	<i>75%</i>	<i>100%</i>
	<i>Cycle</i>	<i>Load</i>	<i>Load</i>	<i>Load</i>	<i>Load</i>
22kW	42/16	100/40	190/75	255/101	316/125
27kW	42/16	108/43	197/78	287/114	359/143

◆ ELECTRICAL SYSTEM

Battery Charge Alternator 12V, 30 Amp
 Static Battery Charger 2.5 Amp
 Recommended Battery..... Group 26, 525CCA
 System Voltage..... 12 Volts

Voltage Regulator

Type..... Electronic
 Sensing Single-phase
 Regulation..... ± 1%
 Features..... V/F Adjustable, Adjustable
 Voltage and Gain LED Indicators

Power Adjustment for Ambient Conditions

Temperature Deration
 3% for every 10° C above °C (22/27kW) 25
 1.65% for every 10° above °F (22/27kW) 104/77
 Altitude Deration
 1% for every 100 m above m (22/27kW) 183
 3% for every 1000 ft. above ft. (22/27kW) 2500/600

Controller R-200C

◆ COLD WEATHER KIT

For cold climates, optional cold weather kit (part number OF6148) is recommended. The kit includes:

- Battery Warmer
- 4" Junction Box with hardware
- 6 qt. pack 5W-30 synthetic oil (engine)

◆ COOLANT HEATER KIT

The optional Coolant Heater Kit (part number OG3065) is available to be used in conjunction with the Optional Cold Weather Kit. This kit includes:

- 1500 watt, 120 volt Engine Block Heater
- Heater Mounting Bracket
- All fittings, hoses and hardware to mount and plumb heater

RECONFIGURING THE FUEL SYSTEM

NOTE:

All models are configured to run on natural gas from the factory.

Before the generator can be operated using a LP fuel source, the fuel system and control panel (refer to the installation drawing for location) must be reconfigured. The steps to reconfigure the generator from a natural gas (NG) to a liquidified petroleum (LP) fuel source are as follows:

◆ FUEL SYSTEM

1. Turn the main gas supply off and disconnect the battery.
2. Remove the carburetor fuel hose from the outlet port of the demand regulator (see Figure 6.1).
3. Disconnect the power wires from the fuel solenoid located on top of the regulator assembly by removing the screw on the front of the connector and pulling the connector forward, away from the solenoid body.
4. Loosen the spring clamp on the small fuel enrichment line and remove the hose from the hose barb.
5. Remove the black pipe assembly from the outlet port of the demand regulator. The solenoid assembly may need to be removed before performing this operation (Figure 6.1).
6. Remove the NG fuel jet (loosen counter clockwise) from the outlet port.
7. Remove the LP fuel jet (loosen counter clockwise) from the jet keeper port on the side of the regulator housing. Install this jet into the outlet port in the regulator casting.

NOTE:

The jet sizes are stamped on the individual jets. The larger jet size is used for running on NG.

8. Install the previously removed NG jet into the jet keeper port on the side of the regulator housing.
9. Install the previously removed black pipe onto the outlet port of the demand regulator. Use pipe sealant on the pipe threads.
10. Reverse steps 1-4 in this procedure to reactivate the demand regulator.
11. Follow the instructions in the Control Panel section.



⚠ **Serious injury or damage may occur if not configured properly. Please consult an Authorized Dealer with any questions.**

Figure 6.1 — Reconfigure the Fuel System

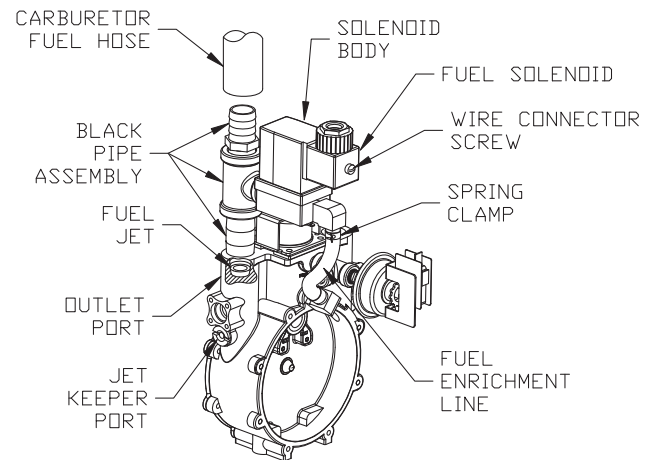

◆ CONTROL PANEL

The fuel select dipswitch is located in the control panel on the circuit board. Engine timing for Natural Gas (NG) Fuel is selected when dipswitch position 4 is set to "ON". Engine timing for LP Fuel is selected when this switch is set to "OFF". See the R-200C Control Panel manual for details.



⚠ **Whenever the Generator's Fuel Regulator is converted from one Fuel type to the other, make sure to configure the Fuel Select Connector for the correct Fuel type.**

ALTERNATOR AC LEAD CONNECTIONS

See "Voltage Codes". This Stationary Emergency Generator may be rated at any one of three voltages, either single-phase or three-phase. The electrical wires in the unit's AC connection (lower) panel should be installed according to the number of leads and the voltage/phase required for the application. If there are any questions regarding lead connection, refer to the wiring diagrams at the back of this manual.

Voltage codes apply to the type of stator assembly installed on a particular generator.

FOUR-LEAD, SINGLE-PHASE STATOR

Four-lead alternators (see Figure 7.1) are designed to supply electrical loads with voltage code "A" (240V, 1-phase, 60 Hz). Electrical power is produced in the stator power windings. These windings were connected at the factory to the main circuit breaker as shown in Figure 7.1.

The rated voltage between each circuit breaker terminal is 240V. The rated voltage between each circuit breaker terminal and the neutral point 00 is 120V.

Figure 7.1 — Four-lead, Single-phase Stator

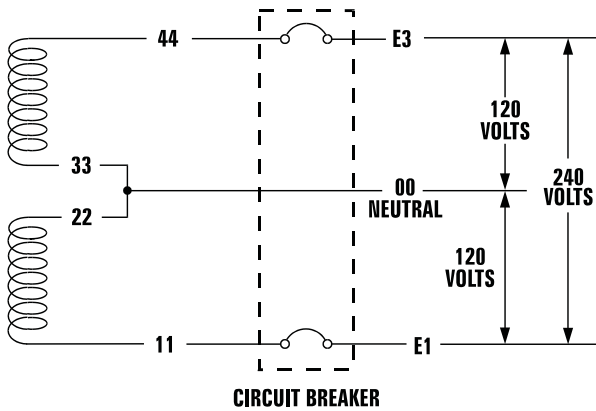

ALTERNATOR POWER WINDING CONNECTIONS

3-PHASE ALTERNATORS

The Stationary Emergency Generator is designed to supply 3-phase electrical loads. Electric power is produced in the alternator power windings. These windings were connected at the factory to the main circuit breaker with a "Y" configuration as shown in Figures 7.2 and 7.3.

The rated voltage between circuit breaker terminals E1-E2, E1-E3 and E2-E3 is either 480V or 208V depending on the model.

The rated voltage between each circuit breaker terminal and the neutral point 00 is either 277V or 120V depending on the model.

Figure 7.2 — Stator Power Winding Connections - 3-phase, 277/480V (6 Lead)

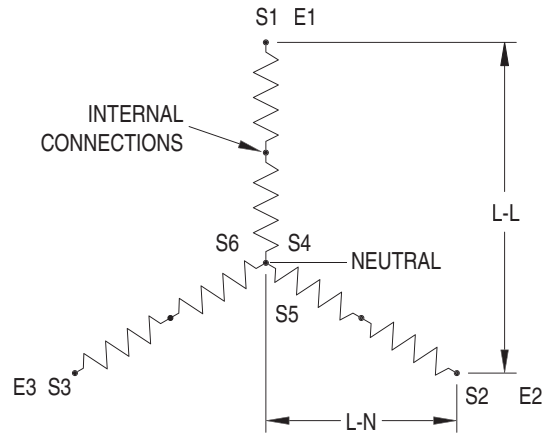
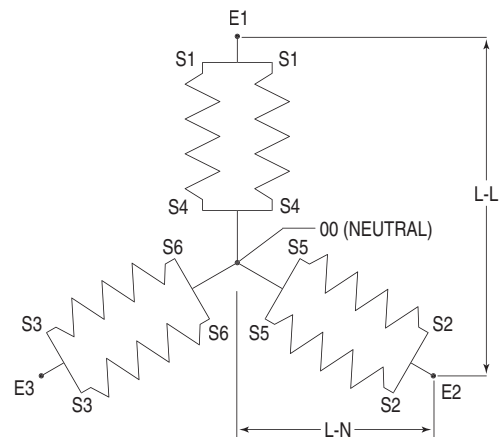

Figure 7.3 — Stator Power Winding Connections - 3-phase, 120/208V (6 Lead)





INSTALLATION

Refer to the separate "Installation Guide" supplied with the unit.

For safety reasons, the manufacturer recommends that this equipment be installed, serviced and repaired by a Service Dealer or other competent, qualified electrician or installation technician who is familiar with applicable codes, standards and regulations. The operator also must comply with all such codes, standards and regulations.

PREPARATION BEFORE START-UP

The instructions in this section assume that the Stationary Emergency Generator has been properly installed, serviced, tested, adjusted and otherwise prepared for use by a competent, qualified installation contractor. Be sure to read the "Safety Rules", as well as all other safety information in this manual, before attempting to operate this (and related) equipment.

Before starting the generator for the first time, the installer must complete the following procedures. For follow-up maintenance information and/or service intervals, please refer to the "Maintenance" section and the "Service Schedule".

◆ TRANSFER SWITCH

If this generator is used to supply power to any electrical system normally powered by an electric utility, the National Electrical Code requires that a transfer switch be installed. The transfer switch prevents electrical backfeed between two different electrical systems. (For additional information, see the applicable transfer switch manual for this unit.) The transfer switch, as well as the generator and other electrical components, must be properly located and mounted in strict compliance with applicable codes, standards and regulations.

◆ FUEL SYSTEM

Make sure the fuel supply system to the generator (a) delivers the correct fuel at the correct pressure and (b) is properly purged and leak tested according to code. No fuel leakage is permitted. See "Specifications" for more information.

◆ GENERATOR SET LUBRICATION

Check the engine crankcase oil level before operating and add oil to the proper level – the dipstick "FULL" mark. Never operate the engine with the oil level below the dipstick "ADD" mark. See "Specifications" and "Engine Oil Recommendations".

Check the oil level in the generator gearbox (if so equipped) prior to initial use and at the intervals indicated by the "Service Schedule." The recommended oil is SAE 90 gear lubricant.

NOTE:

This engine is shipped from the manufacturer with "break-in" oil. This oil should be changed after 30 hours of operation.

◆ PRIOR TO INITIAL START-UP



⚠ Prior to initially starting the generator, it must be properly prepared for use. Any attempt to crank or start the engine before it has been properly serviced with the recommended types and quantities of engine fluids (oil, coolant, fuel, etc.) may result in an engine failure.

◆ ENGINE COOLANT

Have the engine cooling system properly filled with the recommended coolant mixture. Check the system for leaks and other problems. See "Specifications" and "Coolant" sections.

◆ BELT TENSION

Check the engine-fan belt tension and condition prior to placing the unit into service and at recommended intervals. Belt tension is correct when a force of approximately 22 pounds (10 kg), applied midway between pulleys, deflects the belt about 3/8- to 5/8-inch (10 to 16 mm).

◆ ELECTRICAL SYSTEM

Make sure the generator is properly connected to an approved earth ground.

Make sure the generator battery is fully charged, properly installed and interconnected, and ready for use.

NOTE:

Battery charger must be connected to 120 VAC, 15 amp circuit to operate.

Check to ensure that there are no loose electrical connections. Restrain any loose wires to keep them clear of any moving generator set components.

INITIAL INSPECTION FOR GENSET STARTUP

Inspect for the following.

- Freight Damage.
- Manuals present.
- Fluid Levels (Oil, coolant, battery, Gear Drive).
- Correct fuel piping.
- Correct muffler installation for external applications (open units only).
- Adequate air flow, clearances and ventilation per installation drawings and applicable codes.
- Correct AC and DC wire size, connections and grounding. Control and communication wiring to/from the transfer switch must be run in a separate conduit from the AC power leads.
- **Battery charger connection to 120 VAC.**
- Unit secured to pad.



START-UP CHECKLIST



WARNING

⚠ Before working on the Stationary Emergency Generator, ensure the following:

- The AUTO/OFF/MANUAL switch is in the OFF position.
- The 120VAC supply to the battery charger is switched OFF.

◆ PREPARATION FOR START-UP

- Ensure that the 120VAC circuit breaker to the battery charger is open.
- Remove the fuse from the the control panel. Open the front door of the control box and remove the 15 Amp ATO fuse in the lower left-hand corner of the control box.
- Connect the battery cables to the battery. Attach negative battery cable last.
- Close the 120VAC circuit breaker to the battery charger.
- Measure the voltage at the battery before and after the charger is turned on.
- Verify all AC electrical connections are tight at the circuit breaker and transfer switch.
- Visually inspect entire area looking for loose paper, plastic wrappings, leaves, etc.
- Check all hoses clamps fittings for leaks or damage.
- Check all electrical plugs throughout the generator. Ensure each plug is seated correctly and fully inserted into its receptacle.
- Verify the AUTO/OFF/MANUAL switch is in OFF position.
- Open the valve to the engine fuel line.
- Bleed the fuel system of air. (necessary for long fuel lines).
- Open the generator main line circuit breaker.
- Connect a manometer to the gas line and record the static pressure. It must be as listed in the Specifications.
- Insert the fuse into the control panel.
- Move the AUTO/OFF/MANUAL switch to the manual position. The engine should now crank and start.
- Check voltage at the generator terminals.
- For 3-phase units, check phase rotation at the transfer switch terminals. The generator phase rotation must match the utility phase rotation.
- Check for coolant, fuel, oil, and exhaust leaks.
- Close the generators main line circuit breaker.
- Turn the generator set off.
- Connect the UTILITY supply to the transfer switch.
- Set the AUTO/OFF/MANUAL switch to AUTO.
- Disconnect utility power before the transfer switch.
 - Engine should start, transfer to load.
 - Run at least 15 minutes on generator power. Make certain all 3-phase loads are functioning correctly (correct phase rotation).
- Reconnect Utility power
 - Transfer switch will transfer back to Utility and engine will shut down within the given time parameters set up for the specific transfer switch and controller.
- Install all covers, access plates and door panels.
- Put the Owners Manual in a safe and accessible place.
- Make certain the AUTO/OFF/MANUAL switch is in the AUTO position.

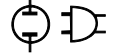
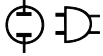

STATIONARY EMERGENCY GENERATOR CONTROL AND OPERATION

Refer to the appropriate control panel operator's manual for this unit.

OPERATING UNIT WITH MANUAL TRANSFER SWITCH

If the Stationary Emergency Generator was installed in conjunction with a transfer switch capable of manual operation only, the following procedure applies. A manually operated transfer switch is one that will not provide automatic start-up and does not include an intelligence circuit.

◆ ENGINE START-UP AND TRANSFER

For additional information, refer to the applicable control panel manual for this unit, as well as any literature pertaining to the specific transfer switch.



⚠ The Maintenance Disconnect Switch and the AUTO/OFF/MANUAL switches (if so equipped) must be set properly, or the generator will crank and start as soon as the utility power to the transfer switch is turned off. Refer to applicable control panel and transfer switch manuals for more information.

⚠ Do not proceed until certain that utility source voltage is available to the transfer switch and the transfer switch main contacts are set to UTILITY.

⚠ Do not attempt manual operation until all power supplies to the transfer switch have been positively turned off, or extremely dangerous - possibly lethal - electrical shock will result.

⚠ Transfer switch enclosure doors should be kept closed and locked. Only authorized personnel should be allowed access to the transfer switch interior. Extremely high and dangerous voltages are present in the transfer switch.

In order to transfer load from the utility source to the generator, follow these directions:

- Turn OFF or disconnect the utility power circuit to the transfer switch, using the means provided (such as the utility source main line circuit breaker).
- Set the transfer handle to its UTILITY (NORMAL) position with load circuits connected to the utility power supply.
- Set the generator's main line circuit breaker to its OFF (or OPEN) position.
- Start the generator.



⚠ Do not crank the engine continuously for longer than 30 seconds, or the heat may damage the starter motor.

- Let engine stabilize and warm up.
- Check all applicable instrument and gauge readings. When certain that all readings are correct, move the transfer switch manual handle to the STANDBY (or EMERGENCY STANDBY) position, i.e., load circuits supplied by the generator.
- Set the generator's main line circuit breaker to its ON (or CLOSED) position.
- Load circuits are now powered by the generator.

◆ RETRANSFER AND SHUTDOWN

For additional information, refer to the applicable control panel manual for this unit, as well as any literature pertaining to the specific transfer switch.

To transfer the load back to the utility power source and shut down the generator, follow these directions:

- Set the generator's main line circuit breaker to its OFF (or OPEN) position.
- Manually move the transfer switch handle to its UTILITY (NORMAL) position, i.e., load circuits connected to the utility.
- Turn ON the utility power supply to the transfer switch, using the means provided (such as the utility power source main line circuit breaker).
- Let the generator run at no-load for a few minutes to stabilize internal temperatures.
- Shut down the generator.

OPERATING UNIT WITH AUTOMATIC TRANSFER SWITCH

If the Stationary Emergency Generator has been installed with an automatic transfer switch, the engine may be started and stopped automatically or manually.

NOTE:

Refer to the applicable manual for your transfer switch and to "Transfer Switch Start Signal Connections". In addition, please note the dangers under "Engine Start-up and Transfer."

MAINTENANCE PERFORMED BY SERVICE DEALERS/CONTRACTORS

⚠ WARNING!

⚠ Before working on the Stationary Emergency Generator, ensure the following:

- The AUTO/OFF/MANUAL switch is in the OFF position.
- The 15A fuse has been removed from the control box.
- The 120VAC supply to the battery charger is switched OFF.
- The negative battery cable has been removed.

EVERY THREE MONTHS

1. Check battery condition.
2. Inspect and test fuel system.
3. Check transfer switch.
4. Inspect exhaust system.
5. Check engine ignition system.
6. Check fan belts.

ONCE EVERY SIX MONTHS

1. Test Engine Safety Devices (low oil pressure, low coolant level, high coolant temperature).

ONCE ANNUALLY

1. Test engine governor; adjust or repair, if needed.
2. Clean, inspect generator.
3. Flush cooling system.
4. Clean/re-gap spark plugs or replace as necessary.

FIRST 30 OPERATING HOURS

1. Change engine "break-in" oil and filter.

FIRST 100 OPERATING HOURS

1. Change engine oil and oil filter. After initial change, service engine oil and filter at 100 operating hours or six months, whichever comes first.
2. Retorque intake and exhaust manifold.

EVERY 500 OPERATING HOURS

1. Service air filter.
2. Check starter.
3. Check engine DC alternator.

COOLING SYSTEM

Air intake and outlet openings in the generator compartment must be open and unobstructed for continued proper operation. This includes such obstructions as high grass, weeds, brush, leaves and snow.

Without sufficient cooling and ventilating air flow, the engine/generator quickly overheats, which causes it to shut down. (See the installation diagram.)

⚠ WARNING!

⚠ The exhaust system parts from this product get extremely hot and remains hot after shutdown. High grass, weeds, brush, leaves, etc. must remain clear of the exhaust. Such materials may ignite and burn from the heat of the exhaust system.

OVERLOAD PROTECTION FOR ENGINE DC ELECTRICAL SYSTEM

Engine cranking, start up and running are controlled by a solid state Engine Controller circuit board. Battery voltage is delivered to that circuit board via a 15 amp fuse. These overcurrent protection devices will open if the circuit is overloaded.

⚠ CAUTION!

⚠ If a circuit breaker opens or a fuse element melts, find the cause of the overload before resetting the circuit breaker or replacing the fuse.

CHECKING FLUID LEVELS

CHECK ENGINE OIL

Check engine crankcase oil level (Figure 10.1) at least every 20 hours of operation, or prior to use.

Figure 10.1 - Oil Dipstick and Oil Fill Cap

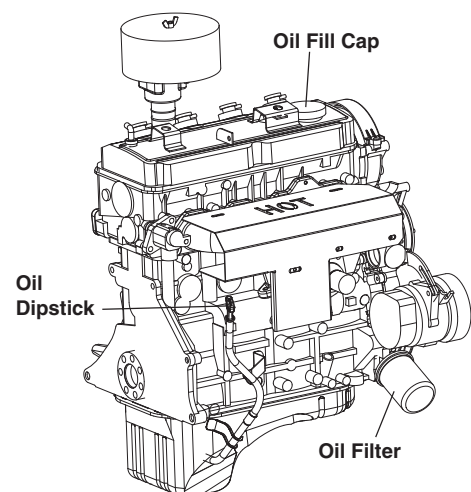

Maintenance

- Remove oil dipstick and wipe dry with a clean, lint-free cloth.
- Install oil dipstick, then remove again.
- Oil should be between FULL and ADD marks.
- If oil level is below the dipstick ADD mark, remove oil fill cap. Add the recommended oil to bring oil level up to the FULL mark. DO NOT FILL ABOVE THE "FULL" MARK. See "Engine Oil Recommendations" for recommended oils.

BATTERY FLUID

Check battery electrolyte fluid based on the Maintenance Schedule. Fluid should cover separators in all battery cells. If fluid level is low, add distilled water to cover tops of separators. DO NOT USE TAP WATER IN BATTERY.

ENGINE COOLANT

Check coolant level in coolant recovery bottle. See the Specifications section.

- Add recommended coolant mixture as necessary.
- Periodically remove radiator pressure cap (only when engine has cooled down) to make sure the coolant recovery system is functioning properly. Coolant should be at bottom of radiator filler neck. If coolant level is low, inspect gasket in radiator pressure cap. Replace cap, if necessary. To have pressure cap tested, contact a Service Facility. Inspect cooling system and coolant recovery system for leaks.

MAINTENANCE OWNER/ OPERATOR CAN PERFORM

⚠ WARNING!

⚠ Before working on the generator, ensure the following:

- The AUTO/OFF/MANUAL switch is in the OFF position.
- The 15A fuse has been removed from the control box.
- The 120VAC supply to the battery charger is switched OFF.
- The negative battery cable has been removed.

CHECK ENGINE OIL LEVEL

Refer to "Checking Fluid Levels".

CHECK BATTERY

- See "Checking Fluid Levels".
- Check battery cables for condition, tightness, corrosion or damage. Clean, tighten or replace as necessary.

EXERCISE SYSTEM

Start the Stationary Emergency Generator engine at least once every seven days and let it run at least 20 minutes. For more detailed exercise information, see the respective sections in the Control Panel Technical Manual that is supplied with the unit.

INSPECT COOLING SYSTEM

- Inspect engine cooling system. See "Maintenance Schedule".
- Check hoses for damage, deterioration, leaks, etc. Correct any discrepancies found.
- Check hose clamps for tightness.

CHECK ENGINE COOLANT LEVEL

See the "Checking Fluid Levels" section.

PERFORM VISUAL INSPECTION

Complete a thorough visual inspection of the entire engine-generator monthly. Look for obvious damage, loose, missing or corroded nuts, bolts and other fasteners. Look for fuel, oil or coolant leaks.

INSPECT EXHAUST SYSTEM

Inspect the exhaust system at least once every three months. Check all exhaust system pipes, mufflers, clamps, etc. for condition, tightness, leaks, security, damage.

CHECK FAN BELT

- Inspect fan belts every three months. Replace any damaged, deteriorated, worn or otherwise defective belt.
- Check fan belt tension. Thumb pressure, exerted midway between pulleys, should deflect about 3/8 to 5/8 of an inch. Adjust belt tension as required.
- Check fan belt alignment (see Figure 10.2).

Figure 10.2 – Fan Belt

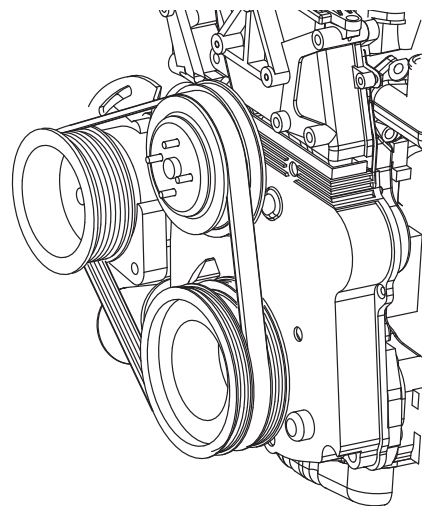

INSPECT ENGINE GOVERNOR

Visually inspect electronic governor.

⚠ DANGER!

⚠ Do not attempt to adjust the governor. Only qualified service facilities should adjust the governor. Excessively high operating speeds are dangerous and increase the risk of personal injury. Low speeds impose a heavy load on the engine when adequate engine power is not available and may shorten engine life. Correct rated frequency and voltage are supplied only at the proper governed speed. Some connected electrical load devices may be damaged by incorrect frequency and/or voltage. Only qualified service technicians should adjust the governed speed.

CHANGING ENGINE OIL

⚠ CAUTION!

⚠ Hot oil may cause burns. Allow engine to cool before draining oil. Avoid prolonged or repeated skin exposure with used oil. Thoroughly wash exposed areas with soap.

Refer to maintenance performed by service facilities for engine oil and filter change frequencies.

Drain the oil while the engine is still warm from running. This means warm up the engine, shut it down and drain immediately as follows:

1. Remove the drain hose from its retaining clip or cut the zip-tie securing the oil drain hose.
2. Loosen and remove OIL DRAIN HOSE CAP. Drain oil completely into suitable container.
3. When all oil has drained, install and tighten OIL DRAIN HOSE CAP and secure drain hose with a new zip-tie, or place the hose in its retaining clip.
4. Turn OIL FILTER (Figure 10.3) counterclockwise and remove. Properly dispose of old filter.

Figure 10.3 – Oil Filter

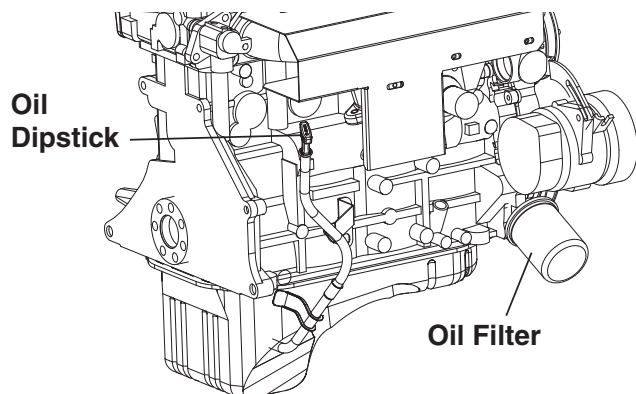

5. Apply light coating of new engine oil to seal of new oil filter.-Install FILTER and tighten by hand only. DO NOT OVER TIGHTEN.
6. Remove OIL FILL CAP and add recommended oil. Crankcase oil capacity is listed in the "Specifications" section.

⚠ CAUTION!

⚠ After refilling the crankcase with oil, always check oil level on dipstick. NEVER OPERATE ENGINE WITH OIL BELOW THE DIPSTICK "ADD" MARK.

7. Start engine and check for oil leaks.
8. Shut OFF engine and wait 10 minutes for the oil to settle down into the oil pan. Recheck oil level on dipstick. DO NOT fill above the dipstick "FULL" mark.
9. Dispose of used oil at a proper collection center.

CHANGING THE ENGINE AIR FILTER

To replace the engine air filter, remove the air filter cover and replace the air filter making sure it is positioned properly before reattaching the cover (Figure 10.4).

See the "Service Schedule," for air filter maintenance.

Figure 10.4 – Engine Air Filter

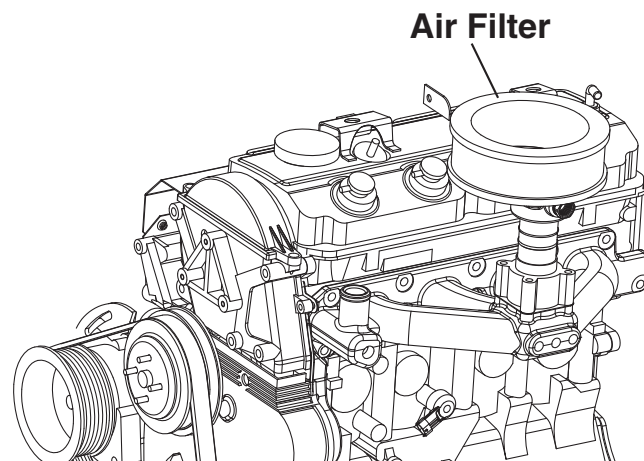

SPARK PLUGS

Reset the spark plug gap or replace the spark plugs as necessary (Figure 10.5).

1. Clean the area around the base of the spark plugs to keep dirt and debris out of the engine. Clean by scraping or washing using a wire brush and commercial solvent. Do not blast the spark plugs to clean.
2. Remove the spark plugs and check the condition. Replace the spark plugs if worn or if reuse is questionable. See the "Service Schedule" section for recommended inspection.
3. Check the spark plug gap using a wire feeler gauge. Adjust the gap to 1.07-1.17 mm (0.042-0.046 inch) by carefully bending the ground electrode (Figure 10.5).

Figure 10.5 – Setting the Spark Plug Gap

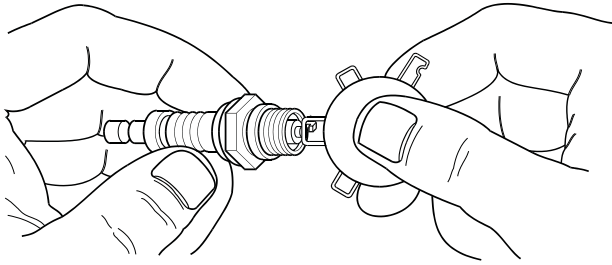

COOLANT CHANGE

Every year, have a service facility drain, flush and refill the cooling system. See “Specifications” for cooling system recommendations.

MISCELLANEOUS MAINTENANCE

CLEANING THE STATIONARY EMERGENCY GENERATOR

Keep the generator as clean and as dry as possible. Dirt and moisture that accumulates on internal generator windings have an adverse effect on insulation resistance.

Periodically clean generator exterior surfaces. A soft brush may be used to loosen caked on dirt. Use a vacuum system or dry, low pressure air to remove any accumulations of dirt. The generator is housed inside an all-weather enclosure, clean the enclosure with a soft, damp cloth or sponge and water.

Once each year have the generator cleaned and inspected by a Service Dealer. That dealer will use dry, low pressure air to clean internal windings. Parts inside the control console should be cleaned and inspected at this time as well.

Finally, have the insulation resistance of stator and rotor windings checked. If insulation resistances are excessively low, the generator may require drying.

BATTERY

All lead-acid storage batteries discharge when not in use. Refer to specific instructions and warnings that accompany the battery. If such information is not available, observe the following precautions when handling a battery:

- DO NOT use jumper cables and a booster battery to crank or start the generator engine.
- DO NOT recharge a weak battery while it is installed in the generator. Remove battery from generator and recharge in a well-ventilated area, away from fuel vapors, sparks, heat or flames.
- Battery electrolyte fluid is an extremely caustic sulfuric solution that can cause severe burns. DO NOT permit fluid to contact eyes, skin, clothing, painted surfaces, wiring insulation, etc. If any battery fluid is spilled, flush the affected area with clear water immediately.
- Always wear safety glasses, rubber apron and gloves when handling a battery.

- Batteries give off explosive hydrogen gas while charging. The gas can form an explosive mixture around the battery for several hours after charging. Any spark, heat or flames can ignite the gas and cause an explosion which can shatter the battery, causing blindness or other serious injury.

BATTERY MAINTENANCE

The battery should be inspected per the “Scheduled Maintenance” section. The following procedure should be followed for inspection:

1. Inspect the battery posts and cables for tightness and corrosion. Tighten and clean as necessary.
2. Check the battery fluid level of unsealed batteries and, if necessary, fill with DISTILLED WATER ONLY. DO NOT USE TAP WATER IN BATTERIES.
3. Have the state of charge and condition checked. This should be done with an automotive-type battery hydrometer.

⚠ DANGER!

⚠ Storage batteries give off explosive hydrogen gas. This gas can form an explosive mixture around the battery for several hours after charging. The slightest spark can ignite the gas and cause an explosion. Such an explosion can shatter the battery and cause blindness or other injury. Any area that houses a storage battery must be properly ventilated. Do not allow smoking, open flame, sparks or any spark producing tools or equipment near the battery.

⚠ Battery electrolyte fluid is an extremely corrosive sulfuric acid solution that can cause severe burns. Do not permit fluid to contact eyes, skin, clothing, painted surfaces, etc. Wear protective goggles, protective clothing and gloves when handling a battery. If fluid is spilled, flush the affected area immediately with clear water.

⚠ Do not use any jumper cables or booster battery to crank and start the generator engine. If the battery has completely discharged, remove it from the generator for recharging.

⚠ WARNING!

⚠ Be sure the AUTO/OFF/MANUAL switch is set to the OFF position, before connecting the battery cables. If the switch is set to AUTO or MANUAL, the generator can crank and start as soon as the battery cables are connected.

⚠ Be sure the 120VAC power supply to the battery is turned OFF, or sparking may occur at the battery posts as the cables are attached and cause an explosion.

BATTERY REPLACEMENT

NOTE:

Unit DOES NOT include battery.

When supplying or replacing the battery, the recommended number and type of battery is listed in the Specifications Section.

NOTE:

The BCI number should be located directly on the battery.

REPAIR PARTS

The later portion of this manual consists of exploded views, parts lists and electrical data pertaining to this generator set. The parts list consists of: (a) an Item Number, (b) a Part Number, (c) Quantity required, and (d) a Description of the part. The Item Number corresponds to an identical number on the exploded view drawing.



Stationary Emergency Generator Service Schedule



SERVICE SCHEDULE

22 KW - 150 KW GASEOUS STATIONARY EMERGENCY GENERATOR

The following is a recommended maintenance schedule for Gaseous Stationary Emergency Generator sets from 22kW to 150 kW in size. The established intervals in the schedule are the maximum recommended when the unit is used in an average service application. They will need to be decreased (performed more frequently) if the unit is used in a severe application. Use calendar time, from the previous maintenance interval to determine the next required maintenance interval.

Service Maintenance Interval Information:

The various service maintenance intervals are designated by interval numbers as follows:

- 1 An early inspection of the generator set to insure it is ready to operate when required and to identify any potential problem areas.



This inspection may be performed by the end user providing the following safety steps are taken to prevent the engine from starting automatically without warning:

To prevent injury, perform the following steps in the order indicated before starting any maintenance:

- Disable the generator set from starting and/or connecting to the load by setting the control panel Auto/Off/Manual switch to the "OFF" position.
- Remove the 15 amp control panel fuse.
- Turn off the battery charger.*
- Remove the negative battery cable.



** The battery charger must be turned off BEFORE removing the battery cable to prevent an over current condition from burning out sensitive control panel components and circuits.*

Following all maintenance, reverse these steps to insure the unit is returned to standby setup for normal operation when required.

- 2 A wear-in service inspection of the generator set to insure it is ready to operate and carry the load when required, and to identify any potential problem areas.

*Performed **ONLY ONCE** following the first three months or the first 30 hours of operation after purchase of the unit.*

This inspection contains some maintenance tasks which require special tools, equipment, and/or knowledge to accomplish and should be performed only by a Service Dealer.

- 3 An operational inspection of the generator set to insure it is ready to operate and carry the load when required, and to identify any potential problem areas.

Performed semi-annually or following each 50 hours of operation of the unit.

This inspection contains some maintenance tasks which require special tools, equipment, and/or knowledge to accomplish and should be performed only by a Service Dealer.

- 4 A mid-level inspection of the generator set to insure it is ready to operate and carry the load when required, and to identify any potential problem areas.

Performed annually or following each 100 hours of operation of the unit.

This inspection contains some maintenance tasks which require special tools, equipment, and/or knowledge to accomplish and should be performed only by a Service Dealer.

- 5 A comprehensive inspection of the generator set to insure it is properly serviced and ready to operate and carry the load when required, and to identify any potential problem areas.

Performed annually or following each 250 hours of operation of the unit.

This inspection contains some maintenance tasks which require special tools, equipment, and/or knowledge to accomplish and should be performed only by a Service Dealer.



Stationary Emergency Generator Service Schedule



Maintenance Tasks	Level 1	Task Comp. (Date-Initials)	Level 2	Task Comp. (Date-Initials)	Level 3	Task Comp. (Date-Initials)	Level 4	Task Comp. (Date-Initials)	Level 5	Task Comp. (Date-Initials)
	Recommended to be done monthly/ 10 hrs.		Required to be done 3 months/ Break-in 30 hrs.		Required to be done Semi-annually/ 50 hrs.		Required to be done Annually/ 100 hrs.		Required to be done Bi-annually/ 250 hrs.	
1. Disable the unit from operating per the first page warning.	○		○		○		○		○	
2. Check the engine oil level. Adjust as necessary.	○		○		○		○		○	
3. Check the engine coolant level. Adjust as necessary.	○		○		○		○		○	
4. Check the engine coolant thermal protection level. Correct as necessary.							○		○	
5. Check the natural gas delivery system for leaks and correct pressure on gas engine driven units. Tighten connections as necessary.	○		○		○		○		○	
6. Check the air inlets and outlets of the enclosure and radiator for debris. Clean as necessary.	○		○		○		○		○	
7. Check the battery electrolyte level and specific gravity if accessible. Adjust as necessary.	○		○		○		○		○	
8. Check the battery posts, cables, and charger for loose connections corrosion, and proper operation. Correct as necessary.	○		○		○		○		○	
9. Check the unit wiring for loose connections, corrosion, and damage. Correct as necessary.	○		○		○		○		○	



Stationary Emergency Generator Service Schedule



Maintenance Tasks	Level 1	Task Comp. (Date-Initials)	Level 2	Task Comp. (Date-Initials)	Level 3	Task Comp. (Date-Initials)	Level 4	Task Comp. (Date-Initials)	Level 5	Task Comp. (Date-Initials)
	Recommended to be done monthly/ 10 hrs.		Required to be done 3 months/ Break-in 30 hrs.		Required to be done Semi-annually/ 50 hrs.		Required to be done Annually/ 100 hrs.		Required to be done Bi-annually/ 250 hrs.	
10. Check the engine accessory drive belts and fan coupling device if equipped for correct tension, wear, weather cracking, and damage. Replace as necessary.			○				○		○	
11. Check the engine valve clearance/ lash. Adjust as necessary.**							○		○	
12. Visually inspect the unit looking for leaks, wear or damage, loose connections or components, and corrosion. Correct as necessary.							○		○	
13. Test the engine and transfer switch safety devices. Correct and/or adjust as necessary.	○		○		○		○		○	
14. Initiate an automatic start and transfer of the unit to site load and exercise it for at least 1 hour looking for leaks, loose connections or components, and abnormal operating conditions. Correct as necessary.							○		○	
15. Replace the engine accessory drive belts.									○	
16. Check gearbox oil level (if equipped).	○		○		○		○		○	
17. Change gearbox oil (if equipped).									○	

** Not required for engines equipped with hydraulic lifters. See the "Specification" section for lifter type.



Stationary Emergency Generator Service Schedule



Maintenance Tasks	Level 1	Task Comp. (Date-Initials)	Level 2	Task Comp. (Date-Initials)	Level 3	Task Comp. (Date-Initials)	Level 4	Task Comp. (Date-Initials)	Level 5	Task Comp. (Date-Initials)
	Recommended to be done monthly/ 10 hrs.		Required to be done 3 months/ Break-in 30 hrs.		Required to be done Semi-annually/ 50 hrs.		Required to be done Annually/ 100 hrs.		Required to be done Bi-annually/ 250 hrs.	
18. Start and exercise the unit at full rated load (use a load bank if the site load is not enough) for at least 2 hours looking for leaks, loose connections or components, and abnormal operating conditions. Correct as necessary.									●	
19. Perform an engine oil analysis (send a sample to a lab for results). Change the engine oil and filters if the analysis results indicate this is required.							●			
20. Change the engine oil.			●				●		●	
21. Replace the engine oil filter(s).			●				●		●	
22. Replace engine spark plugs. Clean and re-gap or replace as necessary.							●			
23. Replace the engine air filter(s).									●	
24. Perform a 5 minute no-load operational run of the unit looking for any post service problems.			●						●	
25. Return the unit to standby setup for operation when required.	●		●		●		●		●	



TROUBLESHOOTING GUIDE

PROBLEM	CAUSE	CORRECTION
Engine won't crank.	<ol style="list-style-type: none"> 15 amp fuse blown. Loose or corroded or defective battery cables. Defective starter contactor. Defective starter motor. Dead or Defective Battery. 5 amp fuse blown. 	<ol style="list-style-type: none"> Replace fuse. Tighten, clean or replace battery cables as necessary. Replace contactor.* Replace starter motor.* Remove, change or replace battery. Replace fuse.*
Engine cranks but won't start	<ol style="list-style-type: none"> Out of fuel. Fuel solenoid (FS) is defective Open Wire #14A from Engine Control circuit board. Spark plugs defective. Door on tank not closed. 	<ol style="list-style-type: none"> Replenish fuel. Replace solenoid.* Reconnect wire. Clean, regap or replace plugs. Close door on tank.
Engine starts hard, runs rough.	<ol style="list-style-type: none"> Flame arrestor (air cleaner) plugged or damaged. Plugged fuel line. Defective spark plugs. Fuel pressure incorrect. 	<ol style="list-style-type: none"> Clean or replace as needed. Unclog fuel line. Clean, regap or replace plugs. Confirm fuel pressure to regulator is as recommended in SPECIFICATIONS.
Engine starts then shuts down.	<ol style="list-style-type: none"> Engine oil level is low. Engine is overheated. Defective Low Oil Pressure Switch Defective Coolant Temperature Switch Defective Control Module circuit board. Coolant Level is Low. Defective Low Coolant Level Switch 	<ol style="list-style-type: none"> Check oil and add oil as needed. Check cooling system for leaks. Replace switch.* Replace switch.* Replace board.* Repair leak - Add coolant. Replace Switch.*
AUTO/OFF/MANUAL Switch at OFF, engine continues to run	<ol style="list-style-type: none"> Defective AUTO/OFF/MANUAL switch Open/disconnected wire #15A between AUTO/OFF/MANUAL switch and Control Module circuit board. Defective Control Module circuit board 	<ol style="list-style-type: none"> Replace switch.* Reconnect/close wire. Replace board.*
No AC output from generator.	<ol style="list-style-type: none"> Check main line circuit breaker. Check circuit breaker & fuses. Transfer switch set to NORMAL position Generator internal failure. Thermal circuit breaker open. 	<ol style="list-style-type: none"> Reset to ON or CLOSED. Reset and replace, if necessary. Set to GENERATOR position. * Auto-reset - Wait 5 min. and attempt restart.

***Contact the nearest Dealer for assistance.**

Warranty

United States Environmental Protection Agency Warranty Statement (Stationary Emergency Spark-Ignited Generators)

Warranty Rights, Obligations and Coverage

The United States Environmental Protection Agency (EPA) and Generac Power Systems, Inc. (Generac) are pleased to explain the Emission Control System Warranty on your new stationary emergency engine. If during the warranty period, any emission control system or component on your engine is found defective in materials or workmanship, Generac will repair your engine at no cost to you for diagnosis, replacement parts and labor provided it be done by a Generac Authorized Warranty Service Facility. Your emission control system may include parts such as the fuel metering, ignition, and exhaust systems and other related emission related components listed below. Generac will warrant the emissions control systems on your 2009 and later model year engines provided there has been no abuse, neglect, unapproved modification or improper maintenance of your engine. For engines less than 130 HP the warranty period is two years from the date of sale to the ultimate purchaser. For engines greater than or equal to 130 HP the warranty period is three years from the date of the engine being placed into service.

Purchaser's/Owner's Warranty Responsibilities

As the engine purchaser/owner you are responsible for the following. 1.) The engine must be installed and configured in accordance to the Generac's installation specifications. 2.) The completion of all maintenance requirements listed in your Owner's Manual. 3.) Any engine setting adjustment must be done in accordance and consistent with the instructions in the Owner's Manual. 4.) Any emission control system or component must be maintained and operated appropriately in order to ensure proper operation of the engine and control system to minimize emissions at all times.

Generac may deny any/or all Emission Control System Warranty coverage or responsibility of the engine, or an emission control system or component on your engine thereof, if it has failed due to abuse, neglect, unapproved modification or improper maintenance, or the use of counterfeit and/or 'gray market' parts not made, supplied or approved by Generac. Warranty service can be arranged by contacting either your selling dealer or a Generac Authorized Warranty Service dealer, 1-800-333-1322 for the dealer nearest you. The purchaser/owner shall be responsible for any expenses or other charges incurred for service calls and/or transportation of the product to/from the inspection or repair facilities. The purchaser/owner shall be responsible for any and/or all damages or losses incurred while the engine is being transported/shipped for inspection or warranty repairs. Contact Generac Power Systems Inc. for additional Emission Control System Warranty related information, Generac Power Systems, Inc. P.O. Box 8, Waukesha, WI 53187, or call 1-800-333-1322 or www.generac.com.

Important Note

This warranty statement explains your rights and obligations under the Emission Control System Warranty, which is provided to you by Generac pursuant to federal law. Note that this warranty shall not apply to any incidental, consequential or indirect damages caused by defects in materials or workmanship or any delay in repair or replacement of the defective part(s). This warranty is in place of all other warranties, expressed or implied. Specifically, Generac makes no other warranties as to the merchantability or fitness for a particular purpose. Any implied warranties which are allowed by law, shall be limited in duration to the terms of the express warranty provided herein. Some states do not allow limitations on how long an implied warranty lasts, so the above limitation may not apply to you.

Emission Related Parts Include the Following (if so equipped)

- | | |
|---|---|
| 1) Fuel Metering System | 3) Ignition System Including |
| 1.1) Gasoline Carburetor Assembly And Internal Components A) Fuel Filter, B) Carburetor, C) Fuel Pump | A) Spark Plug, B) Ignition Module, C) Ignition Coil, D) Spark Plug Wires |
| 1.2) Carburetion Assembly And Its Components A) Fuel Controller, B) Carburetor And Its Gaskets, C) Mixer And It Gaskets, D) Primary Gas Regulator E) Liquid Vaporizer | 4) Exhaust System A) Catalyst Assembly, B) Exhaust Manifold, C) Muffler, D) Exhaust Pipe, E) Muffler Gasket |
| 1.3) Fuel Regulator | 5) Crankcase Breather Assembly Including A) Breather Connection Tube, B) Pcv Valve |
| 2) Air Induction System Including A) Intake Pipe/Manifold, B) Air Cleaner | 6) Oxygen Sensor |
| | 7) Diagnostic Emission-Control System |

Warranty

United States Environmental Protection Agency Compliance Requirements (Stationary Emergency Spark-Ignited Generators)

Purchaser's/Owner's Recordkeeping Responsibilities

The United States Environmental Protection Agency (EPA) and Generac Power Systems, Inc. (Generac) are pleased to explain your record-keeping requirements for compliance with Subpart JJJJ- Standards of Performance for Stationary Spark Ignition Internal Combustion Engines as listed in the Electronic Code of Federal Regulations Title 40 Part 60. As the engine purchaser/owner who operates and maintains their certified emergency stationary engine and emission control system according to applicable emission related guidelines as specified in this Owner's Manual, you are required to meet the following notification and recordkeeping requirements to demonstrate compliance. 1.) Maintain documentation that the engine is certified to meet emission standards. 2.) Recordkeeping of maintenance conducted. 3.) Recordkeeping of the provision allowing natural gas engines to operate using propane for a maximum of 100 hours per year as an alternate fuel solely during emergency operations provided the engine is not certified to operate on propane. 4.) Meet all compliance notifications submitted to the purchaser/owner and maintain all supporting documentation. 5.) Recordkeeping of hours of operation, including what classified the operation as emergency and how many hours are spent for non-emergency operation. For emergency engines greater than or equal to 130 HP, recordkeeping of hours of operation begins January 1, 2011. For emergency engines less than 130 HP, recordkeeping of hours of operation begins January 1, 2009; Engines are equipped with non-resettable hour meters to facilitate recordkeeping.

Specific Air Quality Management or Air Pollution Control Districts may have different and additional record keeping/reporting requirements. Your permit to construct and/or operate the engine may be contingent upon compliance with those requirements. Check with your local Air Quality Management or Air Pollution Control District for specific requirements.

Emergency stationary internal combustion engines (ICE) may be operated for the purpose of maintenance checks and readiness testing, provided that the tests are recommended by Federal, State or local government, Generac, or the insurance company associated with the engine. Maintenance checks and readiness testing of such units is limited to 100 hours per year. There is no time limit on the use of emergency stationary ICE in emergency situations. The purchaser/owner may petition the Administrator for approval of additional hours to be used for maintenance checks and readiness testing, but a petition is not required if the owner maintains records indicating that Federal, State, or local standards require maintenance and testing of emergency ICE beyond 100 hours per year. Emergency stationary ICE may operate up to 50 hours per year in non emergency situations, but those 50 hours are counted towards the 100 hours per year provided for maintenance and testing.

The 50 hours per year for non-emergency situations cannot be used for peak shaving or to generate income for a facility to supply power to an electric grid or otherwise supply power as part of a financial arrangement with another entity. For purchaser/owner of emergency engines, any operation other than emergency operation, maintenance and testing, and operation in non-emergency situations for 50 hours per year, as permitted in this section is prohibited.

If you operate and maintain your certified emergency stationary SI internal combustion engine and emissions control systems in accordance to the specifications and guidelines in this Owner's Manual EPA will not require engine performance testing. If not, your engine will be considered non-certified and you must demonstrate compliance according to Subpart JJJJ - Standards of Performance for Stationary Spark Ignition Internal Combustion Engines as listed in the Electronic Code of Federal Regulations Title 40 Part 60.

Emission-Related Installation Instructions

Your certified emergency stationary engine has pre-set emission control systems or components that require no adjustment. Inspection and replacement of an emissions related component is required to be done so in accordance with the requirements cited in the United States Environmental Protection Agency Warranty Statement or can be arranged by contacting either your selling dealer or a Generac Authorized Warranty Service dealer, 1-800-333-1322 for the dealer nearest you. Failing to follow these instructions when installing a certified engine in a piece of nonroad equipment violates federal law 40 CFR 1068.105 (b), subject to fines or penalties as described in the Clean Air Act.

GROUP A

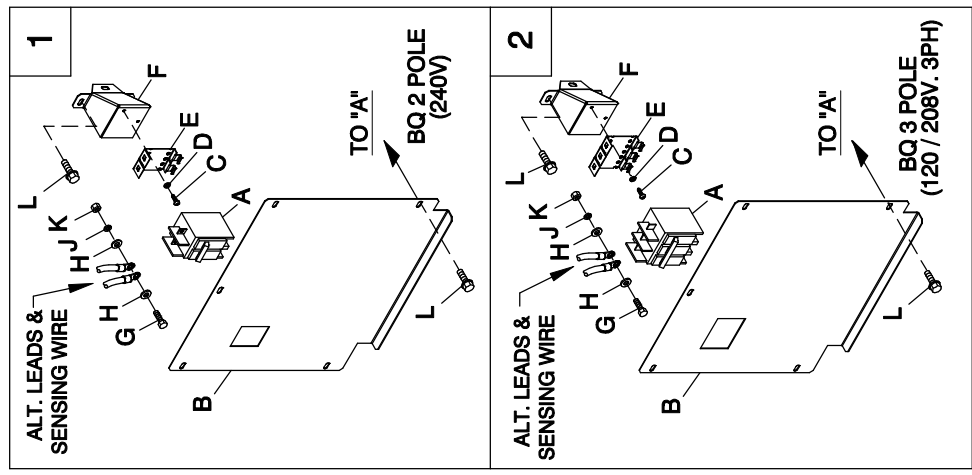
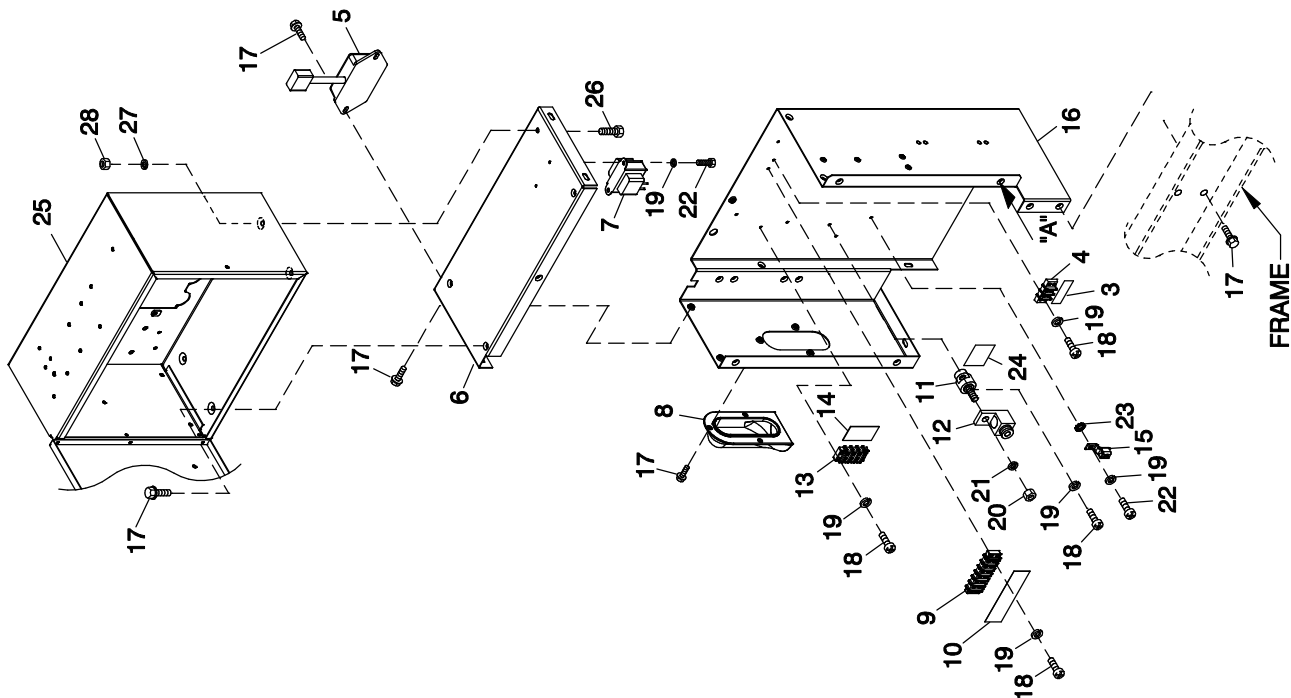

EXPLODED VIEW:
 CONNECTION BOX C1 CPL
 DRAWING #: 0H1711

EXPLODED VIEW: CONNECTION BOX C1 CPL

DRAWING #: 0H1711

GROUP A

APPLICABLE TO:

ITEM	PART #	QTY.	DESCRIPTION
1	N/A	N/A	UL BREAKER BQ2
A	0D5543	1	CB 0090A 2P 240V S BQ2 LL
	0D5544	1	CB 0100A 2P 240V S BQ2 LL
	0A2077	1	CB 0125A 2P 240V S BQ2 LL
B	0G4499	1	CB COVER 20-25K 1P (BQ2)
C	0G9708	2	SCREW PHTT M4-0.7 X 8 ZYC
D	0C2264	2	WASHER LOCK #8-M4
E	0E7890	1	BRKT CB MTG BACK
F	0G4497	1	CIRCUIT BREAKER SUPPORT (BQ)
G	052619	2	SCREW HHC M5-0.8 X 20 G8.8
H	023897	4	WASHER FLAT #10 ZINC
J	049226	2	WASHER LOCK M5
K	051716	2	NUT HEX M5-0.8 G8 CLEAR ZINC
L	0E3257	7	SCREW HWHTF M6-1.0 X 16
2	N/A	N/A	UL BREAKER BQ3
A	049135	1	CB 0070A 3P 240V S BQ3 LL
	062812	1	CB 0080A 3P 240V S BQ3 LL
	040532	1	CB 0100A 3P 240V S BQ3 LL
B	0G4500	1	CB COVER 20-25K 3P (BQ3)
C	0G9708	2	SCREW PHTT M4-0.7 X 8 ZYC
D	0C2264	2	WASHER LOCK #8-M4
E	0E6002	1	BRKT CB MTG BACK
F	0G4497	1	CIRCUIT BREAKER SUPPORT (BQ)
G	052619	3	SCREW HHC M5-0.8 X 20 G8.8
H	023897	6	WASHER FLAT #10 ZINC
J	049226	3	WASHER LOCK M5
K	051716	3	NUT HEX M5-0.8 G8 CLEAR ZINC
L	0E3257	7	SCREW HWHTF M6-1.0 X 16

ITEM	PART #	QTY.	DESCRIPTION
3	0G7991	1	DECAL GTS CUSTOMER CONNECTION
4	048766	REF	BLOCK TERM 20A 2 X 6 X 1100V
5	0A1354A	1	REGULATOR - DC ALT (1.6L ONLY)
6	0G3473	1	CONBOX TOP PANEL SUPPORT
7	0F6366A	1	XFMR 208 TO 16V 6VA (208V. ONLY)
	0F6366B	1	XFMR 240 TO 16V 6VA (240 / 480V.)
8	0G3524	1	COVER BELL HOUSING CONBOX
9	046357	REF	BLOCK TERM 20A 6 X 6 X 1100V
10	0G7992	1	DECAL RTS CUSTOMER CONNECTION
11	057073	1	JUNCTION BLOCK 3/8-16
12	057329	1	LUG SLDLSS 350-#6X13/32 AL/CU
13	0D4698	REF	BLOCK TERM 20A 6 X 3 X 1100V
14	0G9337	1	DECAL CHARGER POWER 120VAC
15	025433	1	LUG SLDLSS #6-14 X 13/64 CU
16	0G3472	1	CONBOX BACK & SIDES 1.6L
17	0E3257	22	SCREW HWHTF M6-1.0 X 16
18	0C2212	8	SCREW PHTT M4-0.7 X 16 ZYC
19	022264	11	WASHER LOCK #8-M4
20	022241	1	NUT HEX 3/8-16 STEEL
21	022237	1	WASHER LOCK 3/8
22	0G9708	3	SCREW PHTT M4-0.7 X 8 ZYC
23	023762	1	WASHER SHAKEPROOF EXT #10 STL
24	0A9457	1	DECAL NEUTRAL
25	0G4577E	REF	ASSY R-200 3600 1.6L
	0G4578E	REF	ASSY R-200 1800 1.6L
	0H1433E	REF	ASSY R-200C 1800 RPM 2.4L
26	047411	1	SCREW HHC M6-1.0 X 16 G8.8
27	022097	1	WASHER LOCK M6-1/4
28	049813	1	NUT HEX M6 X 1.0 G8 YEL CHR

GROUP A

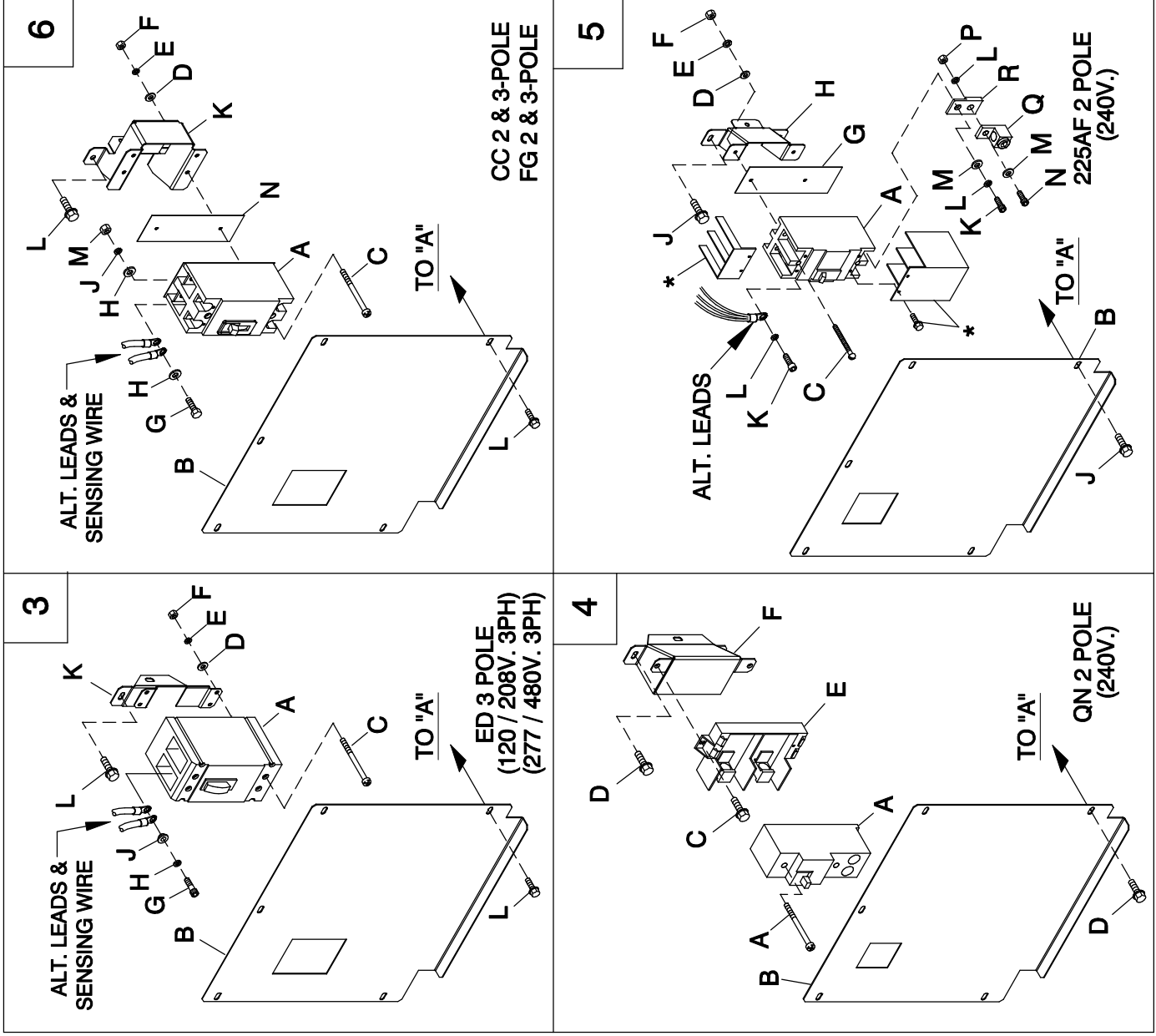

EXPLODED VIEW: CONNECTION BOX C1 CPL
DRAWING #: 0H1711

GROUP A

APPLICABLE TO:

ITEM	PART #	QTY.	DESCRIPTION
3	N/A	N/A	UL BREAKER ED
A	0D5548	1	CB 0030A 3P 480V S ED4 LL
	0D5549	1	CB 0035A 3P 480V S ED4 LL
	0D5551	1	CB 0045A 3P 480V S ED4 LL
	0D5552	1	CB 0050A 3P 480V S ED4 LL
	0D5556	1	CB 0090A 3P 480V S ED4 LL
	0D5557	1	CB 0100A 3P 480V S ED4 LL
	0D9693	1	CB 0125A 3P 480V S ED4 LL
B	0G4502	1	CB COVER 20-30K 3P (ED)
C	066715	4	SCREW RHM #8-32 X 4-1/2
D	038150	4	WASHER FLAT #8 ZINC
E	022264	4	WASHER LOCK #8-M4
F	022471	4	NUT HEX #8-32 STEEL
G	0A8278	3	SCREW SHC 1/4-28 X 3/4 G8.8 NZ
H	022097	3	WASHER LOCK M6-1/4
J	0D5621	3	WASHER-STEP 1/20DX9/32ID BRASS
K	0G4498	1	CIRCUIT BREAKER SUPPORT (ED)
L	0E3257	7	SCREW HWHTF M6-1.0 X 16
4	N/A	N/A	UL BREAKER QN
A	0E7283	1	CB 0150A 2P 240V S QN2 LL
B	0G3474	1	CONBOX FRONT COVER 1.6L QN 2P
C	074908	2	SCREW HHTT M5-0.8 X 10 BP
D	0E3257	7	SCREW HWHTF M6-1.0 X 16
E	0E3664	1	BASE, QN CIRCUIT BREAKER
F	0G4112	1	BREAKER SUPPORT BRACKET 30KW

ITEM	PART #	QTY.	DESCRIPTION
5	N/A	N/A	UL BREAKER
A	0G5249	1	CB 150A 2 POLE 240V 225AF
*	W/CB	2	TERMINAL COVER CB
B	0G5735	1	CB COVER 30K G 225AF
C	053640	2	SCREW RHM #8-32 X 3-1/4
D	038150	2	WASHER FLAT #8 ZINC
E	022264	2	WASHER LOCK #8-M4
F	022471	2	NUT HEX #8-32 STEEL
G	0F8432A	1	INSULATOR CB 2P 225AF
H	0G5734	1	CIRCUIT BREAKER SPPRT G 225AF
J	0E3257	8	SCREW HWHTF M6-1.0 X 16
K	049897	4	SCREW SHC M8-1.25 X 20 G8
L	022129	4	WASHER LOCK M8-5/16
M	022145	6	WASHER FLAT 5/16-M8 ZINC
N	058306	2	SCREW SHC M8-1.25 X 25 G12.9
P	045771	2	NUT HEX M8-1.25 G8 CLEAR ZINC
Q	0F8451	2	LUG SLDLSS 300 MCM-6 AL/CU
R	0F8843	2	BUS BAR 200A LUG ADAPTOR
6	N/A	N/A	CC/FG CIRCUIT BREAKER
A	0H4745	1	CB 0100A 2P 240V E CC LL
	0H4746	1	CB 0125A 2P 240V E CC LL
	0H4747	1	CB 0150A 2P 240V E CC LL
	0H4913	1	CB 0100 3P 240V E CC LL
	0H4914	1	CB 0125 3P 240V E CC LL
	0H5488	1	CB 0080 3P 480V E FG LL
	0H5489	1	CB 0090 3P 480V E FG LL
B	0H4657	1	CB COVER 20-30K 1P (CC)
	0H5392	1	CB COVER 3 POLE TYPE (CC & FG)
(2)C	053640	2 / 4	SCREW RHM #8-32 X 3-1/4 (CC ONLY)
	0H5721	2 / 4	SCREW PPHM #8-32 X 1-3/4 ZINC (FG ONLY)
(2)D	038150	2 / 4	WASHER FLAT #8 ZINC
(2)E	022264	2 / 4	WASHER LOCK #8-M4
(2)F	022471	2 / 4	NUT HEX #8-32 STEEL
(2)G	091526	2 / 3	SCREW PPHM M5-0.8 X 12 ZNC
(2)H	023897	4 / 6	WASHER FLAT #10 ZINC
(2)J	049226	2 / 3	WASHER LOCK M5
K	0H4656	1	CIRCUIT BREAKER SUPPORT (CC)
	0H5604	1	CIRCUIT BREAKER SUPPORT (FD)
L	0E3257	3	SCREW HWHTF M6-1.0 X 16
(2)M	051716	2 / 3	NUT HEX M5-0.8 G8 CLEAR ZINC
(1) N	0H4698	REF	INSULATOR CB 2P E TYPE CC (CC ONLY)
	0H4698A	REF	INSULATOR CB 3P E TYPE CC (CC ONLY)
	0H4698A	1	INSULATOR CB 3P E TYPE CC (FG ONLY)

(1) SUPPLIED WITH BREAKER

(2) QTY. REQ. FOR 2-POLE BREAKERS / QTY. REQ. FOR 3-POLE BREAKERS.

GROUP A

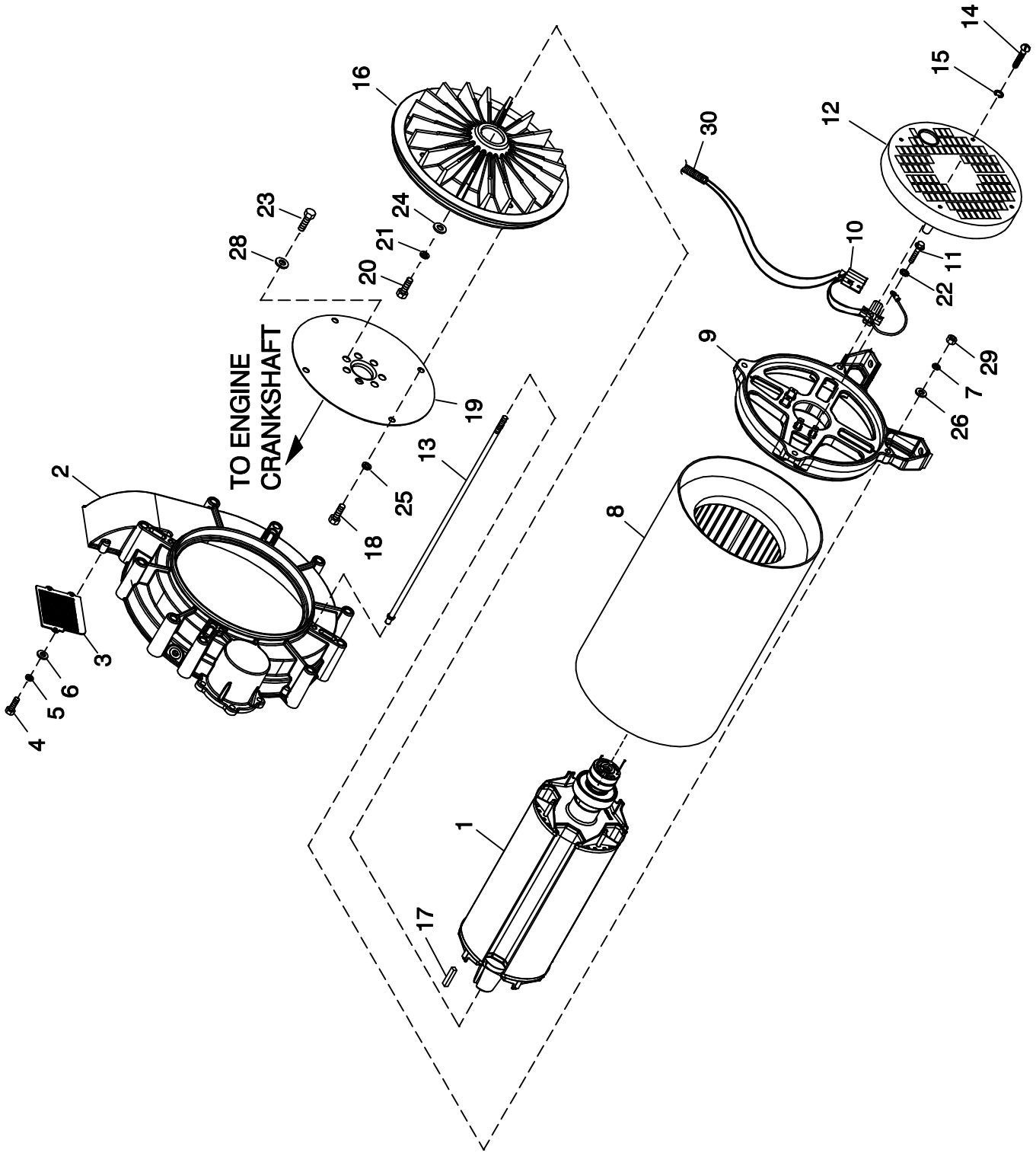

EXPLODED VIEW:
ALT COMMON PARTS 2.4L 10" ALT 22KW & 27KW
DRAWING #: 0G8881

EXPLODED VIEW: ALT COMMON PARTS 2.4L 10" ALT 22KW & 27KW
 DRAWING #: 0G8881

GROUP A

APPLICABLE TO:

ITEM	PART #	QTY.	DESCRIPTION
1	0G9009	1	RTR-104-22AD1 HI EFF
	0G9011	1	RTR-104-27AD2 HI EFF
	0G9341	1	RTR-104-22GD1 HI EFF
	0G9342	1	RTR-104-27GD2 HI EFF
2	0G8318A	1	HOUSING BLOWER MACHINED 2.4L
3	0G8366	1	BLOWER HOUSING SCREEN
4	020746	3	SCREW PPHM M5-0.8 X 8 ZINC
5	049226	3	WASHER LOCK M5
6	051713	3	WASHER FLAT M5
7	022129	4	WASHER LOCK M8-5/16
8	0G9008	1	STR-104-22AD1 HI EFF
	0G9010	1	STR-104-27AD1 HI EFF
	0G9339	1	STR-104-22GD1 HI EFF
	0G9340	1	STR-104-27GD1 HI EFF
9	0A5382A	1	BEARING CARRIER REAR LG PILOT
10	075591	1	ASSY HOLDER BRUSH
11	051787	4	SCREW HHC M4-0.7 X 16 G8.8
12	0A5601A	1	COVER REAR BEARING
13	0G8827	4	STUD M8-1.25 475 LONG (27KW)
	0G8827A	4	STUD M8-1.25 418 LONG (22KW)
14	0A9375	4	SCREW RHM #10-24 X 2
15	022152	4	WASHER LOCK #10
16	0G8311	1	FLYWHEEL & RINGGEAR ASSY 2.4L
17	042558	1	KEY SQ 3/8 X 1 STEEL
(1) 18	051756	4	SCREW HHC M10-1.5 X 20 C8.8
19	0G8364	1	PLATE FLEX 2.4L 10" ALT
(1) 20	053607	1	SCREW HHC M12-1.75 X 35 G8.8
21	051769	1	WASHER LOCK M12
22	023365	4	WASHER SHAKEPROOF INT #8
(1) 23	0G0114	7	SCREW HHC M12-1.25 X 15 C10.9
24	072578	1	SPACER ROTOR SHAFT
25	0D8427	4	WASHER LOCK M10 RIBBED ZINC
26	0A8830	4	WASHER FLAT .34 ID X .75 OD
27	029333A	7	TIE WRAP UL 7.4"X .19" BLK (NOT SHOWN)
28	063076	7	WASHER FLAT .531ID X 1.062OD
29	045771	4	NUT HEX M8-1.25 G8 CLEAR ZINC
30	077043A	1	CONDUIT FLEX .38"ID (18" LG)
31	077043C	1	CONDUIT FLEX .75"ID (18" LG) (NOT SHOWN)

(1) APPLY MEDIUM STRENGTH BLUE THREADED LOCKING FLUID TO THREADS.

GROUP C

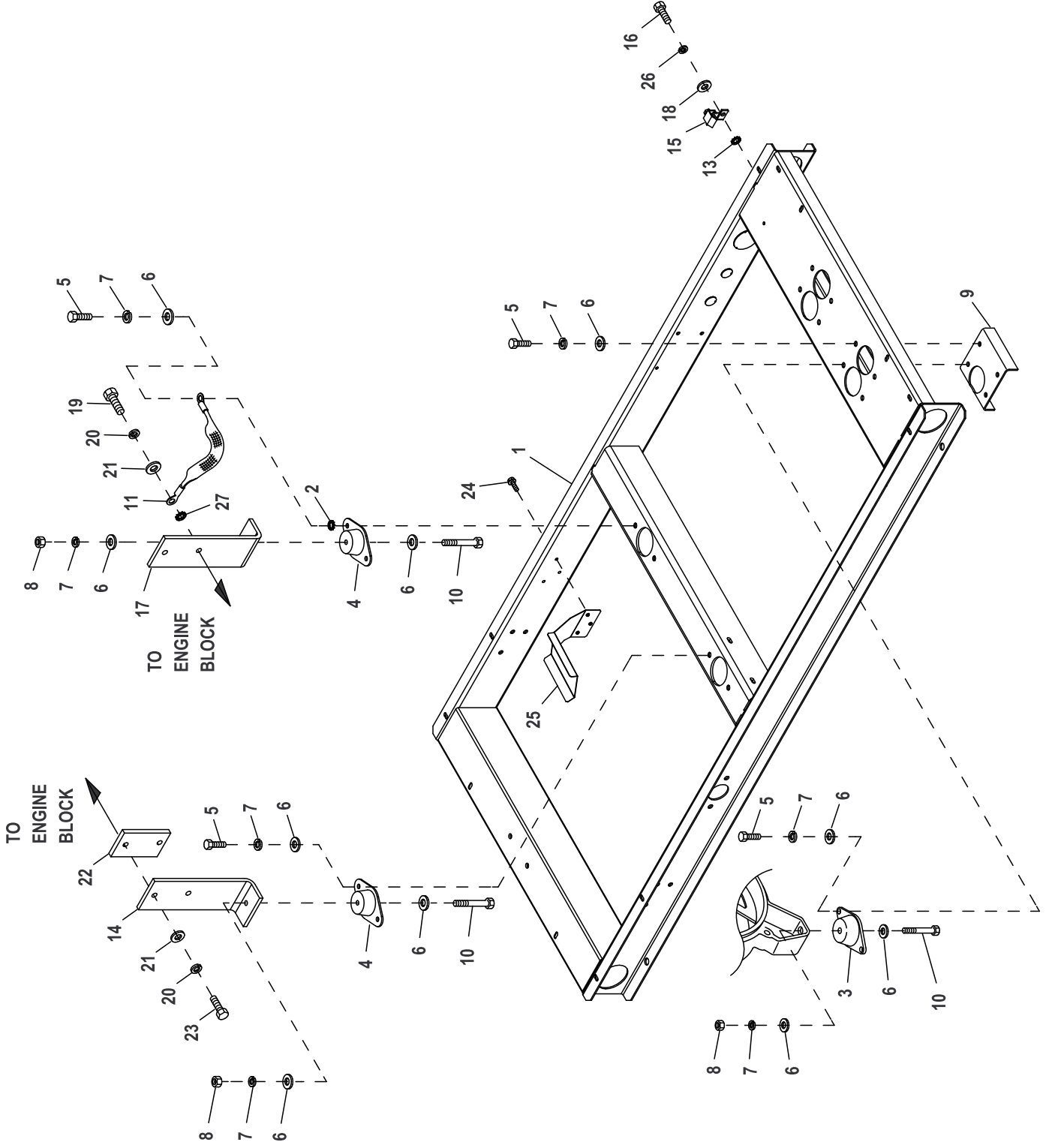

EXPLODED VIEW: MOUNTING BASE 2.4L**DRAWING #: 0G8784****GROUP C****APPLICABLE TO:**

ITEM	PART#	QTY.	DESCRIPTION
1	0G83760ST03	1	MOUNTING BASE 2.4L
2	027482	2	WASHER SHAKEPROOF EXT 5/16 STL
3	070936	2	DAMPENER VIBRATION
4	070936C	2	VIB. ISO. 70-75 DURO
5	039253	12	SCREW HHC M8-1.25 X 20 G8.8
6	022145	20	WASHER FLAT 5/16 ZINC
7	022129	16	WASHER LOCK M8-5/16
8	045771	4	NUT HEX M8-1.25 G8 YEL CHR
9	0G3461	2	ALTERNATOR SUPPORT BLOCK OFF
10	051730	4	SCREW HHC M8-1.25 X 60 G8.8
11	021991	1	EARTH STRAP
13	026850	1	WASHER SHAKEPROOF EXT 1/4 STL
14	0G8429AST03	1	SUPPORT ENGINE LEFT SIDE
15	055414	1	LUG SLDLSS #2-#8 X 17/64 CU
16	047411	1	SCREW HHC M6-1.0 X 16 G8.8
17	0G84290ST03	1	SUPPORT ENGINE RIGHT SIDE
18	022473	5	WASHER FLAT 1/4-M6 ZINC
19	062963	2	SCREW HHC M10-1.25 X 30 C8.8
20	046526	4	WASHER LOCK M10
21	022131	4	WASHER FLAT 3/8-M10 ZINC
22	0F9596A	1	SPACER LH ENGINE MOUNT
23	052211	2	SCREW HHC M10-1.25 X 40 C8.8
24	0C2454	3	SCREW HWHT M6-1 X 16 N WA Z/JS
25	0H6121	1	HEAT SHIELD 2.4L G2
26	022097	1	WASHER LOCK M6-1/4
27	025507	1	WASHER LOCK EXT 7/16 STL

GROUP C

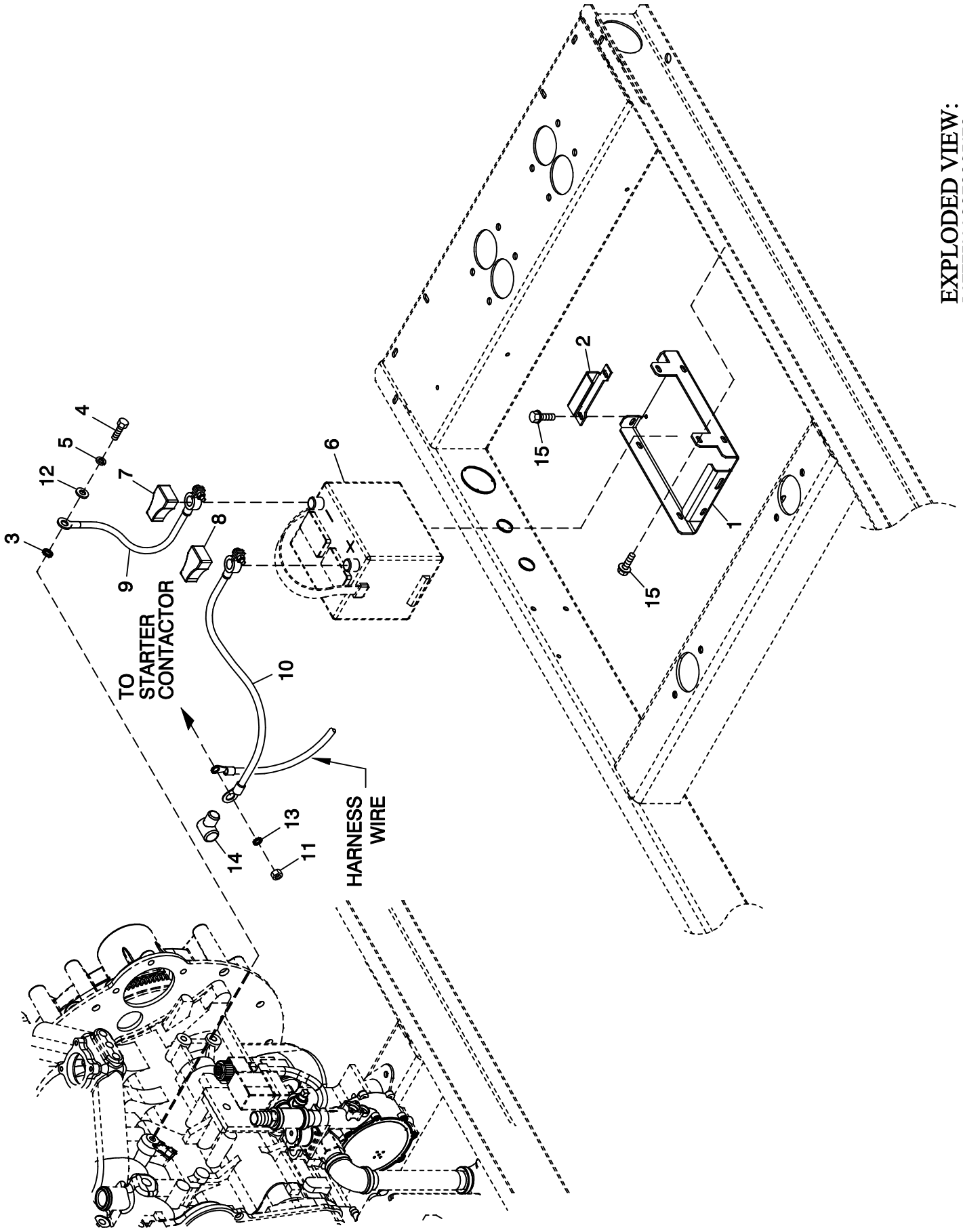

EXPLODED VIEW:
BATTERY ACCESSORIES
DRAWING #: 0G8894

EXPLODED VIEW: BATTERY ACCESSORIES

DRAWING #: 0G8894

GROUP C

APPLICABLE TO:

ITEM	PART #	QTY.	DESCRIPTION
1	0F3408C	1	BATTERY TRAY, C1 & C2
2	0F3411	1	STRAP BATTERY RETAINMENT
3	025507	1	WASHER SHAKEPROOF EXT 7/16 STL
4	052212	1	SCREW HHC M10-1.25 X 25 C8.8
5	046526	1	WASHER LOCK M10
6	077483	REF	BATTERY 12VDC 75-AH 26 (SOLD AS AN OPTION)
7	050331A	REF	BATTERY POST COVER RED +
8	050331	REF	BATTERY POST COVER BLK -
9	038805J	1	CABLE BATTERY BLACK #1 X 30.00
10	038804M	1	CABLE BATTERY RED #1 X 21.00
11	045771	REF	NUT HEX M8-1.25 G8 YEL CHR
12	022131	1	WASHER FLAT 3/8-M10 ZINC
13	027482	1	WASHER SHAKEPROOF EXT 5/16 STL
14	0F3976	1	BOOT CONTACTOR CABLES
15	0C2454	6	SCREW THF M6-1 X 16 N WA Z/JS

GROUP D

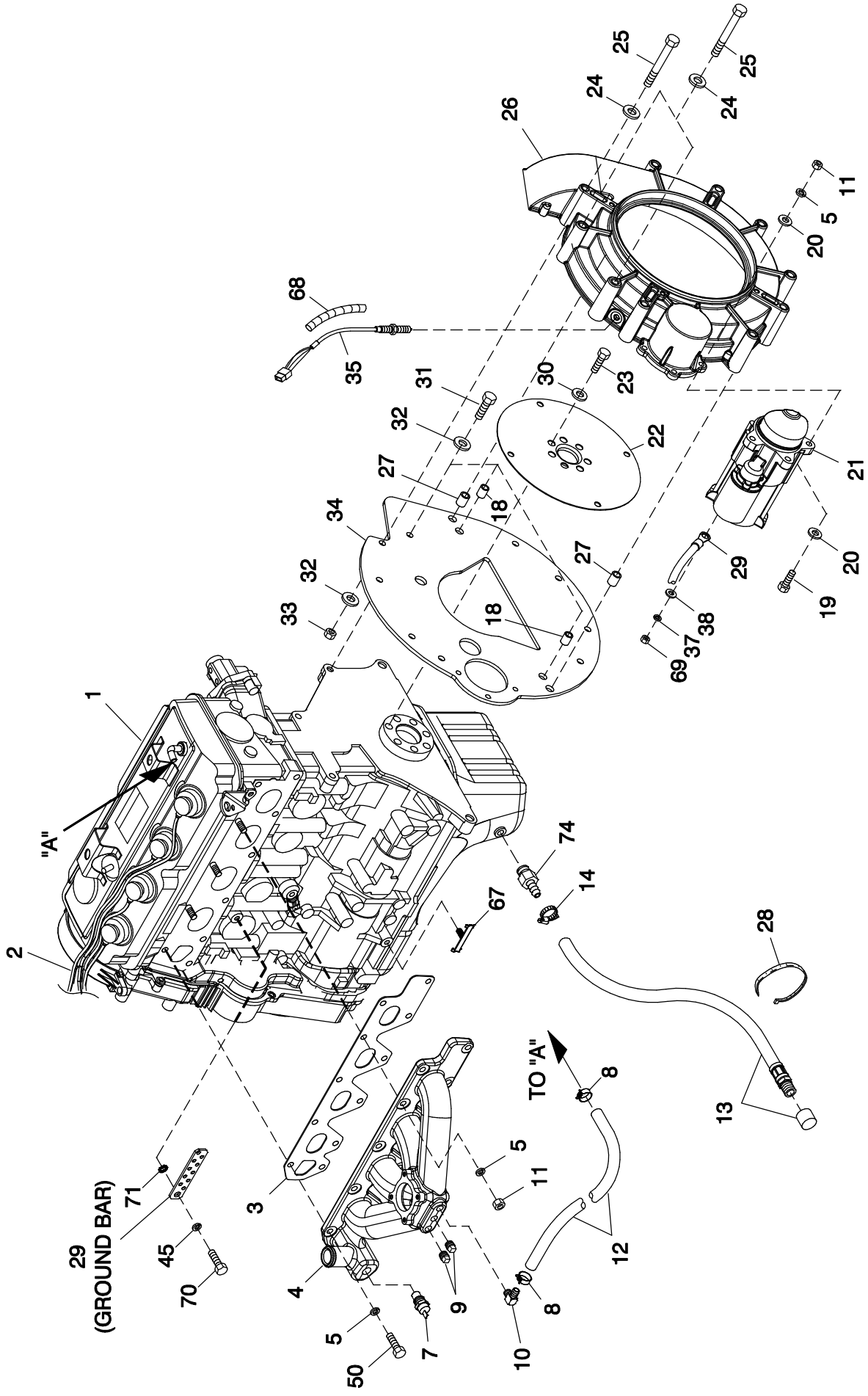

EXPLODED VIEW:
ENG COMMON PARTS 2.4L G2
DRAWING #: 0G8885

GROUP D

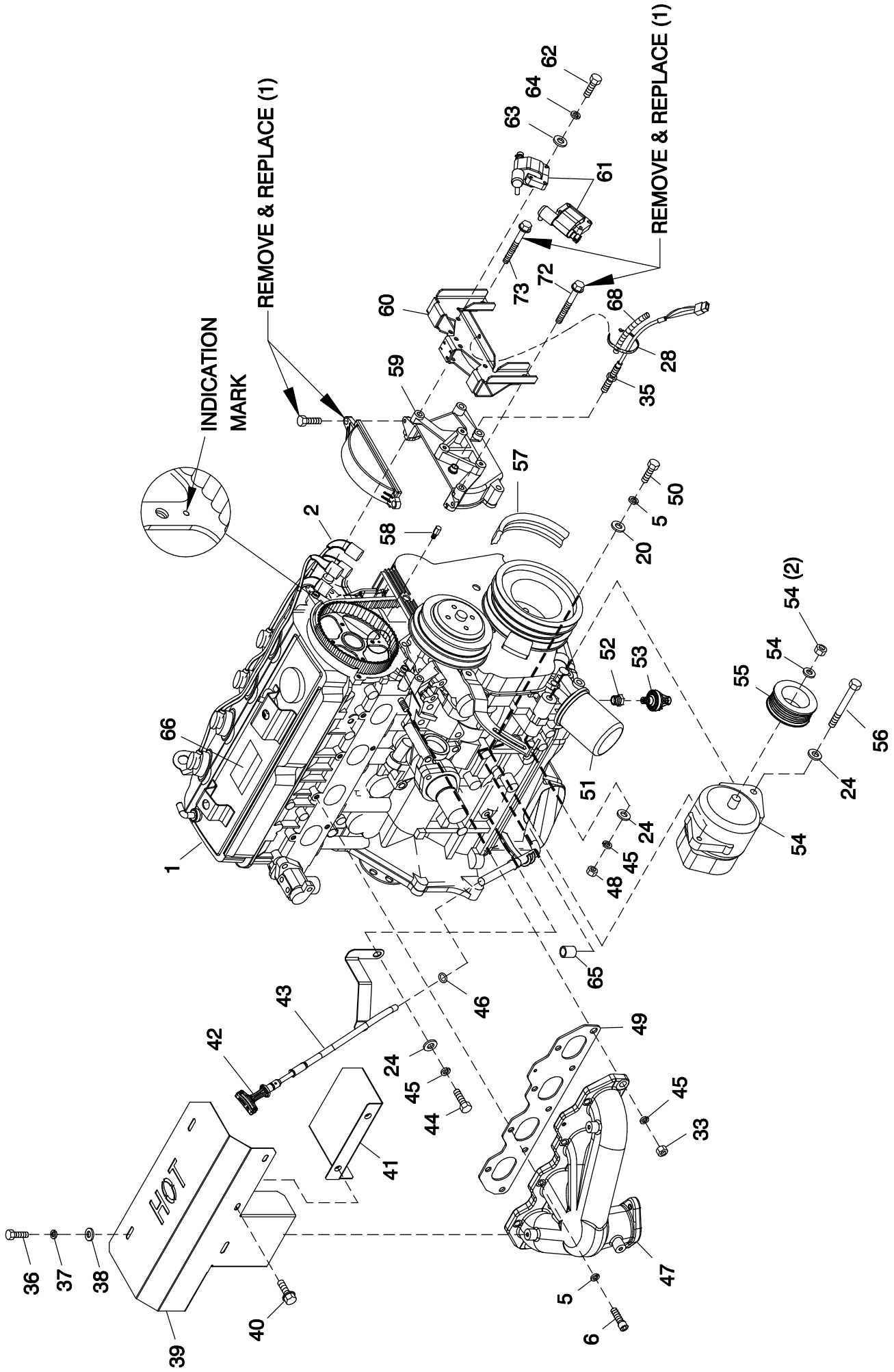

EXPLODED VIEW:
ENG COMMON PARTS 2.4L G2
DRAWING #: 0G8885

REVISION: H-5089-H
DATE: 9/23/09

EXPLODED VIEW: ENG COMMON PARTS 2.4L G2
DRAWING #: 0G8885

GROUP D

APPLICABLE TO:

ITEM	PART #	QTY.	DESCRIPTION
1	0H1619	1	ENGINE 2.4L G2
2	0G8854	1	SPARK PLUG WIRE SET 2.4L G2 IG
(1) 3	0G0950	1(REF)	GASKET INTAKE MANIFOLD G2
4	0G8488	1	MANIFOLD INTAKE (MACHINED)
5	022129	22	WASHER LOCK M8-5/16
6	058306	7	SCREW SHC M8-1.25 X 25 C12.9
7	0A6751	1	SWITCH HI-TEMP 245D X 3/8 NPT
	0E0502	1	TEMPERATURE SENDER, DELPHI
8	048031J	2	CLAMP HOSE BAND .63
9	026073A	2	PLUG STD PIPE 1/4 STEEL SQ HD
10	049340	1	BARBED EL 90 1/4 NPT X 3/8
11	045771	6	NUT HEX M8-1.25 G8 CLEAR ZINC
12	047290	1	HOSE 3/8 ID SINGLE BRAID (15" LG)
13	069860B	1	HOSE OIL DRAIN ASSY 16"
14	0C7649	1	CLAMP HOSE .38-.87

ITEM	PART #	QTY.	DESCRIPTION
18	0G8759A	2	BUSHING GUIDE 11.3MM LONG
19	039287	3	SCREW HHC M8-1.25 X 45 C8.8
20	022145	7	WASHER FLAT 5/16-M8 ZINC
21	0G7461	1	MOTOR STARTER
22	0G8364	1 (REF)	PLATE FLEX 2.4L 10" ALT
(2) 23	0G0114	7(REF)	SCREW HHC M12-1.25 X 15 C10.9
24	022131	13	WASHER FLAT 3/8-M10 ZINC
25	0G9255	10	SCREW HHC M10-1.25 X 100 PC8.8
26	0G8318A	1 (REF)	HOUSING BLOWER MACHINED 2.4L
27	0G8759	2	BUSHING GUIDE 19.3MM LONG
28	029333A	3	TIE WRAP UL 7.4"X .19" BLK
29	0G8877	1	HARN ENG 2.4L R-200B 1800 NO-T (NOT SHOWN)
	0H1275	1	HARN ENG 2.4L R-200C 1800 RPM (NOT SHOWN)
30	063076	7 (REF)	WASHER FLAT .531 ID X 1.062 OD
31	052830	3	SCREW HHC M10-1.25 X 45 C8.8
32	0D8427	11	WASHER LOCK M10 RIBBED ZINC
33	046525	10	NUT HEX M10-1.25 G8 YEL CHR
34	0G8365	1	ADAPTER ENGINE PLATE 2.4L G2
(2) 35	0D2244M	2	ASSY MAGPICKUP (3/8-24 MALE)
36	043116	3	SCREW HHC M6-1.0 X 12 G8.8
37	022097	4	WASHER LOCK M6-1/4
38	022473	4	WASHER FLAT 1/4-M6 ZINC
39	0G92210AS0R	1	SHIELD EXHAUST
40	0D6029	3	SCREW HHTT M6-1.0 X 16 ZYC
41	0G0792A	1	SHIELD HEAT SML
42	0F2664H	1	ASSY DIPSTICK W/TEXT GTH-530
43	0G8427A	1	ASSY DIPSTICK TUBE 2.4 G2
44	052213	1	SCREW HHC M10-1.25 X 20 C8.8
45	046526	5	WASHER LOCK M10
46	0G3823	1	O-RING SIZE 9.0MM X 2.0MM NITR
47	0G3910	1	EXHAUST MANIFOLD G2 (MACHINE)
48	045772	1	NUT HEX M10-1.5 G8 YEL CHR
(1) 49	0G0951	1(REF)	GASKET EXHAUST MANIFOLD
50	0A8258	9	SCREW HHC M8-1.25 X 25 C10.9
(1) 51	0A45310244	1(REF)	FILTER 1.5L/2.4L G2 OIL
52	042574	1	ADAPTOR 1/8 NPTF TO 1/8 BSPT
53	0A8584	1	SWITCH OIL PRESSURE 10 PSI 2 POL
(2) 54	0E9868A	1	ALTERNATOR DC W/OUT PULLEY
55	0G2750	1	PULLEY 69 OD DC ALTERNATOR
56	0E4507	1	SCREW HHC M10-1.5 X 120 C8.8
57	0D3488S	1	BELT SERPENTINE 37.0"
58	0G1472A	1	CAM SENSOR PIN ASSY
59	0G1477	1(REF)	COVER CAM GEAR G2 REWORKED
60	0G8852	1	BRACKET ASM-2.4L COIL G2
61	0G8853	4	COIL-2.4L G2 IGNITION
62	034413	8	SCREW HHM #10-32 X 1-1/4
63	023897	8	WASHER FLAT #10 ZINC
64	022152	8	WASHER LOCK #10
(1) 65	0G9520	1 (REF)	PLUG TAPER
66	0G7313	1 (REF)	DECAL EMISSION CTRL INFO 2.4L
67	0F4001E	1	ANCHOR HARNESS
68	077043H	2	CONDUIT FLEX .25"ID (6"LG)
69	049813	1	NUT HEX M6 X 1.0 G8 YEL CHR
70	052213	1	SCREW HHC M10-1.25 X 20 C8.8
71	025507	1	WASHER SHAKEPROOF EXT 7/16 STL
(1) 72	052265	1(REF)	SCREW HHC M8-1.25 X 65 C8.8
(1) 73	052203	1(REF)	SCREW HHC M8-1.25 X 70 C8.8
74	0C1852	1	ADAPTER DRAIN OIL

(1) SUPPLIED WITH ENGINE.
(2) APPLY MEDIUM STRENGTH BLUE THREAD LOCKING FLUID TO THREADS.

APPLICABLE TO:

THIS PAGE IS LEFT INTENTIONALLY BLANK

GROUP C

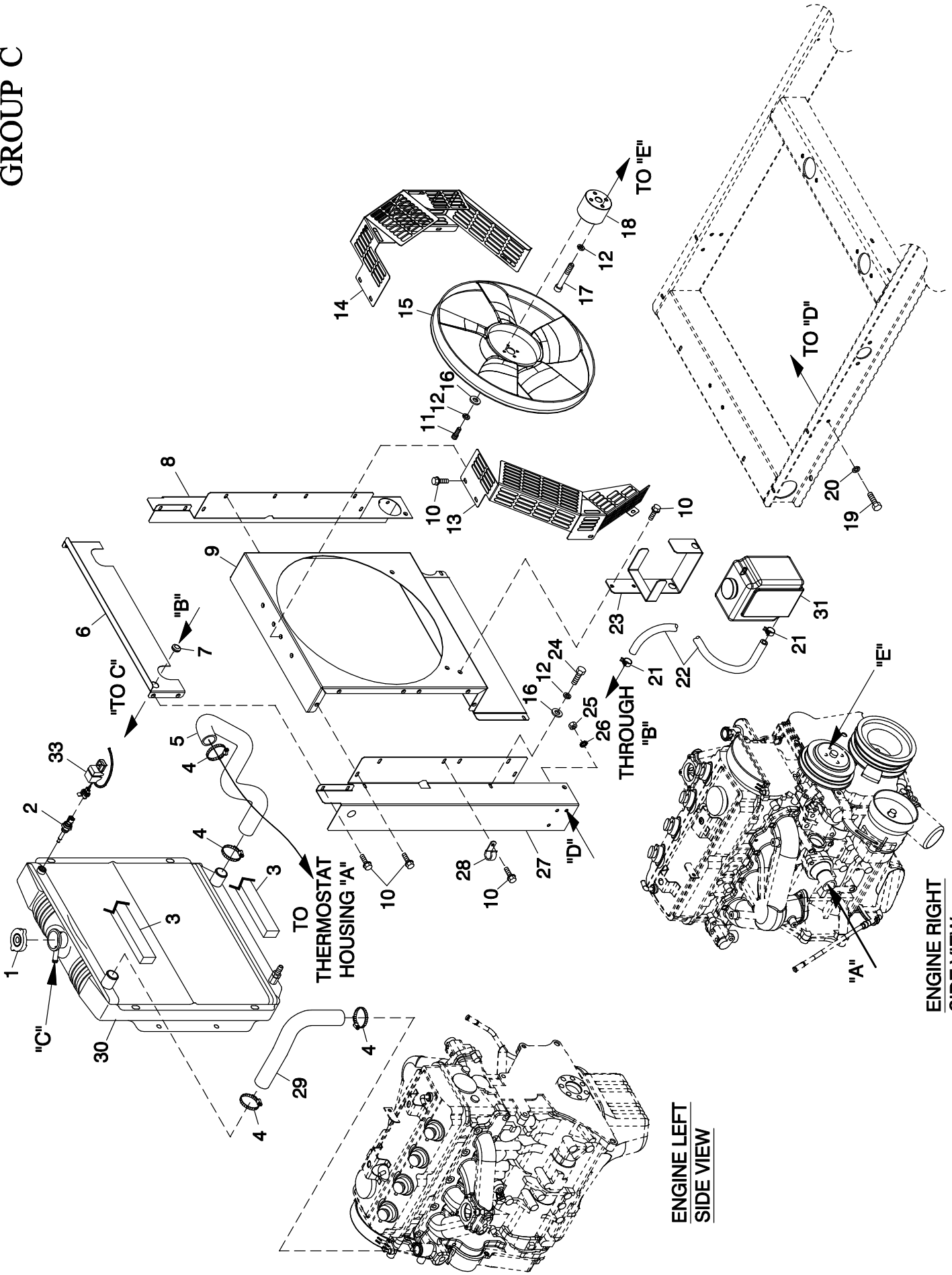

EXPLODED VIEW:
 COOLING SYSTEM 2.4L C1
 DRAWING #: 0G8886

ENGINE LEFT
 SIDE VIEW

ENGINE RIGHT
 SIDE VIEW

TO
 THERMOSTAT
 HOUSING "A"

EXPLODED VIEW: COOLING SYSTEM 2.4L C1

DRAWING #: 0G8886

GROUP C

APPLICABLE TO:

ITEM	PART #	QTY.	DESCRIPTION
1	046627	1	CAP RADIATOR 14PSI
2	0E2507	1	PROBE COOLANT LEVEL 3/8NPTF
	0H1827	1	PROBE COOLANT LEVEL 3/8-18NPTF (USE WITH I/N 33, P/N 0H1851)
3	052250	2	TAPE FOAM 1 X 1 (21" LG)
4	099502	4	CLAMP HOSE #24 B1.06-2.00
5	0G8831	1	HOSE LOWER RADIATOR 2.4L
6	0G81290GS0R	1	BLOCK OFF RADIATOR 2.4L
7	0F9504	1	GROMMET 5/8"X 1 1/8"X 5/16"
8	0G81280GS0R	1	SUPPORT RADIATOR RH SIDE 2.4L
9	0G81260GS0R	1	VENTURI 2.4L
10	0C2454A	25	SCREW THF M6-1 X 12 N WA Z/J
11	042568	4	SCREW HHC M6-1.0 X 20 G8.8
12	022097	12	WASHER LOCK M6-1/4
13	0G89420GS0R	1	GUARD FAN LH
14	0G89430GS0R	1	GUARD FAN RH
15	0G8803	1	FAN COOL 460MM DIA 5 BLADE
16	022473	8	WASHER FLAT 1/4-M6 ZINC
(1) 17	082460	4	SCREW SHC M6-1.0 X 65 C12.9
18	0G8993	1	ADAPTER FAN 2.4L
(1) 19	039253	6	SCREW HHC M8-1.25 X 20 G8.8
20	022129	6	WASHER LOCK M8-5/16
(2) 21	048031C	2 (REF)	CLAMP HOSE BAND 1/4
22	029032	1	HOSE 9/32 ID (47" LG)
23	080713	1	BRACKET COOLANT TANK
24	0C8566	4	SCREW HHFC M6-1.0 X 20 G8.8
25	045771	6	NUT HEX M8-1.25 G8 CLEAR ZINC
26	027482	6	WASHER SHAKEPROOF EXT 5/16 STL
27	0G81270GS0R	1	SUPPORT RADIATOR LH SIDE 2.4L
28	082121A	1	CLIP-J VINYL COAT .375 ID
29	0G8830	1	HOSE UPPER RADIATOR 2.4L
30	0E9837C	1	RADIATOR
31	076749	1	TANK COOLANT RECOVERY
32	029333A	9	TIE WRAP UL 7.4" X .19" BLK (NOT SHOWN)
(3) 33	0H1851	1	ASSY PCB LCL SENSOR (USE WITH I/N 2, P/N 0H1827 ONLY)

(1) APPLY MEDIUM STRENGTH BLUE THREAD LOCKING FLUID TO THREADS.

(2) INCLUDED WITH I/N 25.

(3) USE WITH R-200 CONTROL PANEL ONLY.

GROUP E

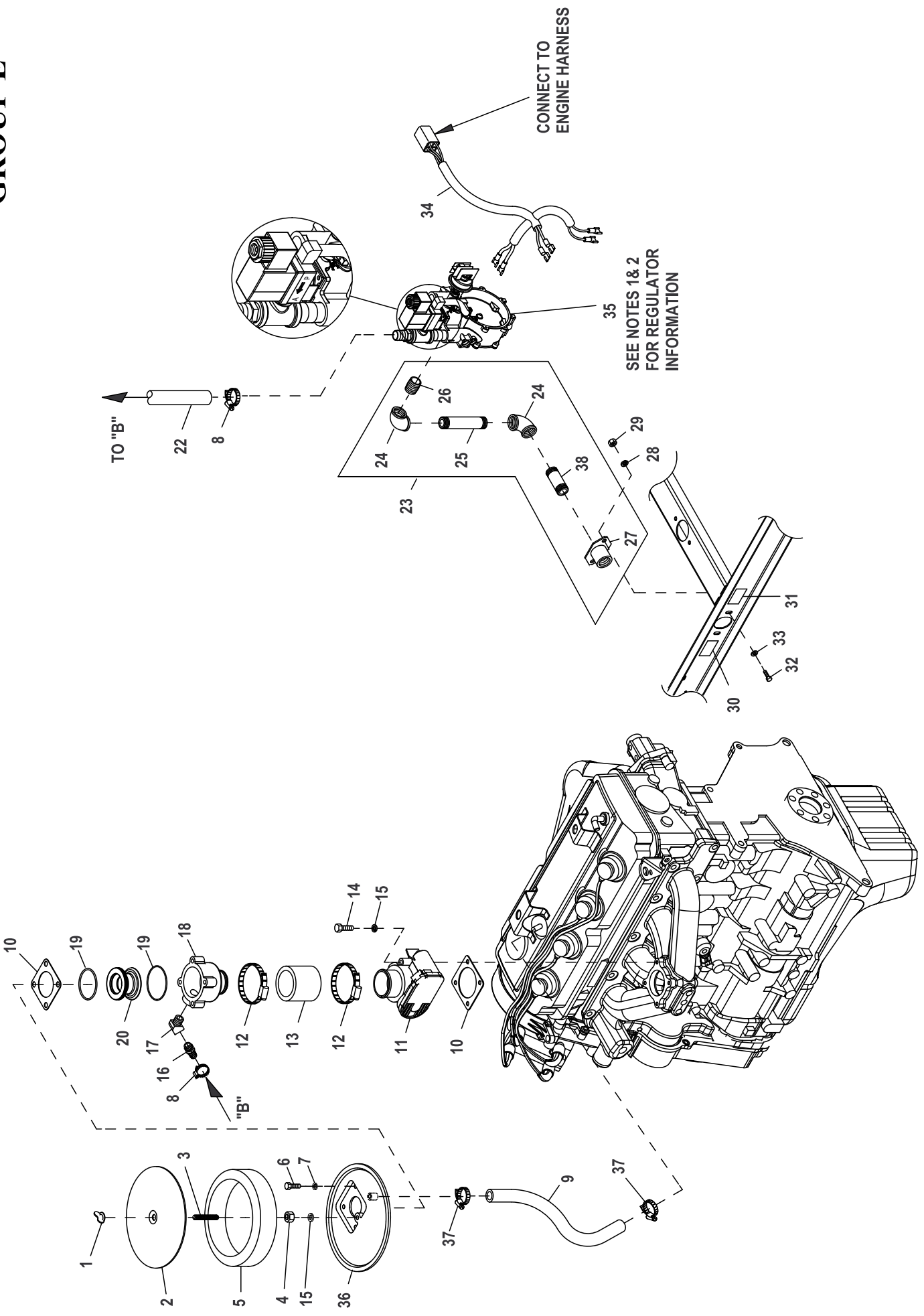

EXPLODED VIEW: FUEL SYSTEM 2.4L G2 22&27KW**DRAWING #: 0G8814****GROUP E****APPLICABLE TO:**

ITEM	PART#	QTY.	DESCRIPTION
1	037561	1	NUT WING 1/4-20 NYLK
2	0A5547	1	COVER AIR CLEANER
3	062522	1	STUD TH 1/4-20 X 3 G2 ZNC FULL
4	022127	1	NUT HEX 1/4-20 STEEL
5	059402	1	FILTER ELEMENT
6	091526	4	SCREW PPHM M5-0.8 X 12 ZNC
7	049226	4	WASHER LOCK M5
8	057823	2	CLAMP HOSE #10 .56-1.06
9	047290	1	HOSE 3/8 ID SINGLE BRAID (15" LG)
10	0E6586	2	GASKET BOSCH 32
11	0E4395	1	ACTUATOR BOSCH 32 GOVERNOR (25 & 35KW)
12	035685	2	CLAMP HOSE #28 1.32-2.25
13	057753B	1	HOSE 1.5 ID X 2 LG 20R4 (35KW)
14	051767	4	SCREW HHC M6-1.0 X 45 C8.8 FTH
15	022097	5	WASHER LOCK M6-1/4
16	047527	1	BARBED STR 1/2 NPT X 3/4
17	0E8286	1	STREET EL 45D 1/2 NPT BRASS
18	0G4573C	1	MIXER ACTUATOR 32MM MACHINED (25KW)
19	0E7121	2	O-RING 47.625 ID X 2.38 WIDTH
20	0F7790H	1	VENTURI THROTTLE 19MM (25KW)
22	059057	1	HOSE 3/4 ID SAE-30R2 (18" LG)
23	0G9348	1	ASSY REG INLET NPT FITTINGS
(1) 24	026812	2	ELBOW 90D 3/4 NPT
(1) 25	076691	1	NIPPLE PIPE 3/4NPTX4.5 BLK IRN
(1) 26	026915	1	NIPPLE CLOSE 3/4 X 1.375
(1) 27	075580	1	FLANGE FUEL INLET
28	022129	2	WASHER LOCK M8-5/16
29	045771	2	NUT HEX M8-1.25 G8 YEL CHR
30	0D1509	1	DECAL INLET PRESSURE
(2) 31	075436	1	DECAL - FUEL INLET
32	039253	2	SCREW HHC M8-1.25 X 20 G8.8
33	022145	2	WASHER FLAT 5/16 ZINC
34	0F6155	1	HARNES FUEL JUMPER SINGLE REG
35	0G1397C	1	FUEL REG REWORK 2.4 1800 22/27
36	0E0519A	1	ADAPTER, CARBURETOR W/PVC CONN
37	048031J	2	CLAMP HOSE BAND .63
(1) 38	026490	1	NIPPLE PIPE 3/4NPT X 2

(1) INCLUDED IN I/N 23 (REGULATOR ASY)

(2) FOR LP VAPOR APPLICATION SUBSTITUE LPG FUEL INLET DECAL P/N 050280 FOR NG FUEL INLET DECAL P/N 050279 (ITEM 31).

NOTES:

1. REGULATOR (I/N 35) AS SHOWN IN ILLUSTRATION IS SET UP FOR NATURAL GAS APPLICATION.

2. TO CONFIGURE REGULATOR FOR LP VAPOR, REFER TO THE "RECONFIGURING THE FUEL SYSTEM" SECTION OF THIS MANUAL.

GROUP F

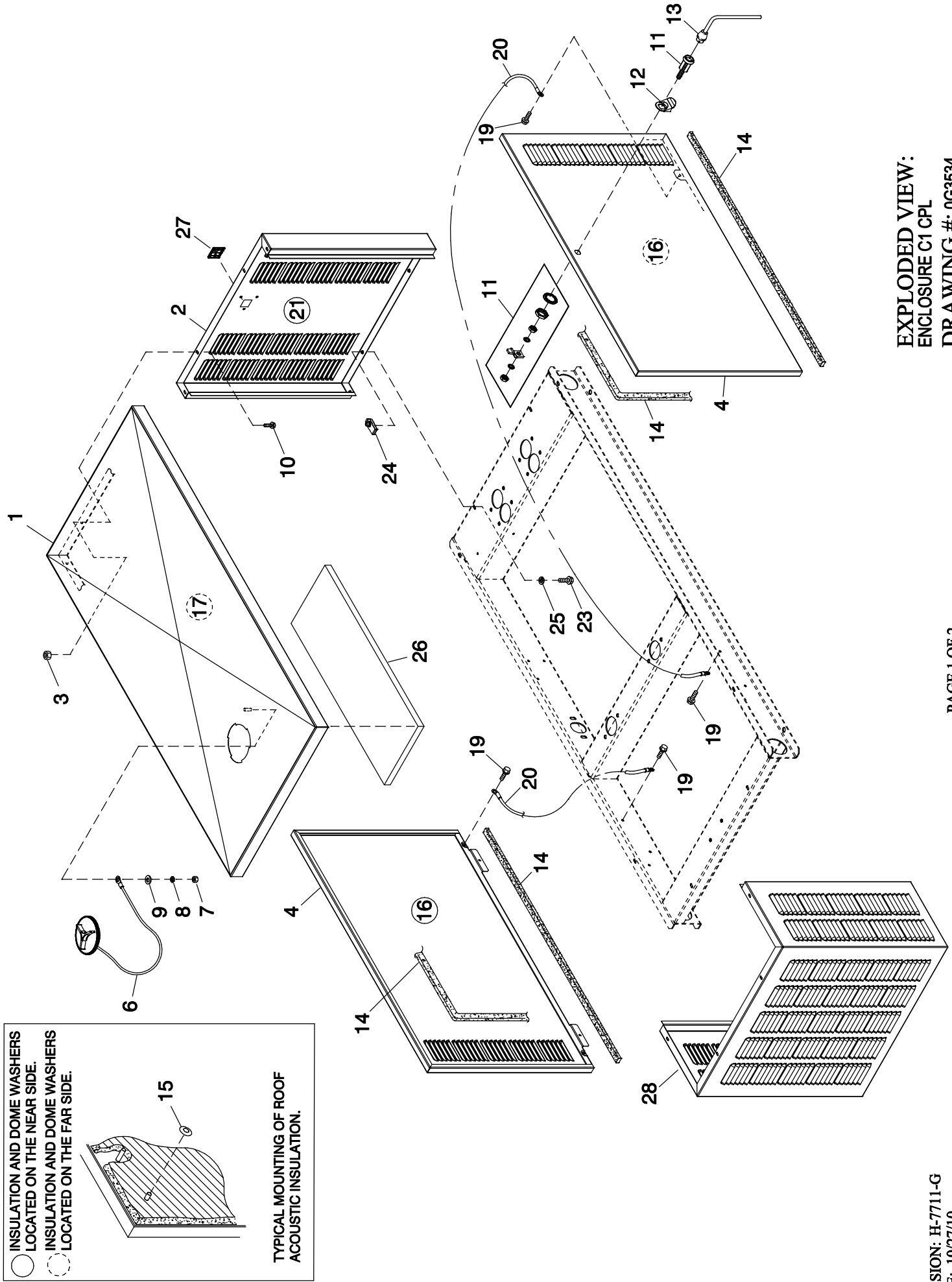

EXPLODED VIEW:
ENCLOSURE C1 CPL
DRAWING #: 0G3534

APPLICABLE TO:

ITEM	PART #	QTY.	DESCRIPTION
(2) 1	0G33370ALOR	1	ROOF 1.6L C1
(2) 2	0J14640ALOR	1	REAR INTAKE WRAP C1
(1) 3	077992	10	NUT HEX LOCK M6-1.0 SS NY INS
(2) 4	0J14630ALOR	2	DOOR LEFT/RIGHT SIDE C1
6	0F4487A	1	ASSY ACCESS COVER
7	022127	1	NUT HEX 1/4-20 STEEL
8	022097	1	WASHER LOCK M6-1/4
9	022473	1	WASHER FLAT 1/4-M6 ZINC
10	0C2454	10	SCREW THF M6-1 X 16 N WA Z/JS
11	0F5048D	2	WISE-ACTION LATCH, SLOTTED CIR
12	0F5049	2	TAB PULL
13	0F8869D	1	KEY VISE-ACTION LATCH,SLOT CIR
14	089961	1	FOAM STRIP 3/4"WIDE X 3/16"THK (294"LG)
15	078115	8	WASHER SELF LOCKING DOME
16	0H7518	2	INSULATION SIDE DOOR C1
17	0H7518A	1	INSULATION ROOF C1
19	0E3257	4	SCREW HWHTF M6-1.0 X 16
20	0912970090	2	ASSY WIRE 14AWG GRN/YEL (32.25"LG)
21	0H7518B	1	INSULATION REAR C1
23	0C8566	10	SCREW HHFC M6-1.0 X 20 G8.8
24	0H0412	10	NUT SPRINGCLIP M6-1.0
25	022097	10	WASHER LOCK M6-1/4
(3) 26	0H7529	1	FOIL ALUMINUM WITH ADHESIVE
27	0H1208A	1	RF COVER PLATE-PLASTIC-BISQUE
	0H1208B	1	RF COVER PLATE-PLASTIC-GREY
(2) 28	0G33350ALOR	1	FRONT DISCHARGE WRAP 1.6L C1

(1) ALUMINUM ENCLOSURE NOTE: ALL ROOF PANELS ARE TO BE SECURED USING ITEM NUMBERS 10 (THREAD FORMING FASTENER) & 3 (LOCK NUT). THE LOCK NUT IS TO BE INSTALLED AFTER THREAD FORMING FASTENER HAS PENETRATED THROUGH EXTRUSIONS IN ENCLOSURE PANELS.

(2) SHEET METAL PARTS LISTED IN THE BOM TABLE ARE REPRESENTING GENERIC PARTS (NO COLOR).

- MANUFACTURING: FOR CORRECT MATERIAL AND COLOR REFER TO AS400 BOM.
- CUSTOMER: FOR CORRECT MATERIAL AND COLOR OF REPLACEMENT PARTS REFER TO "REPLACEMENT SHEET METAL PARTS ORDERING GUIDE-0H7169" INCLUDED IN THE MANUAL OR AVAILABLE ON THE GENERAC WEBSITE.

(3) USED ON 1.6L UNITS ONLY.

GROUP F

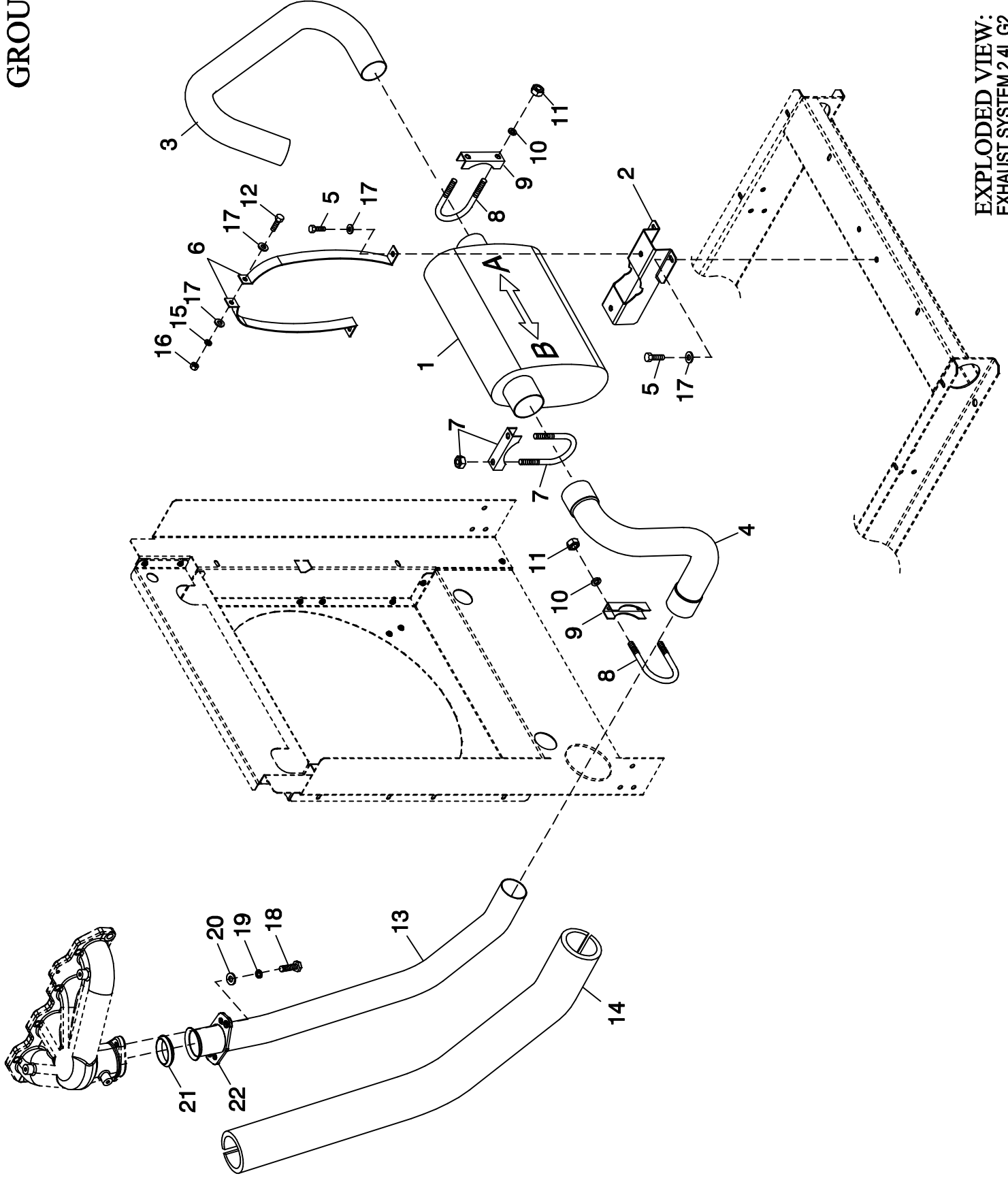

EXPLODED VIEW:
EXHAUST SYSTEM 2.4L G2
DRAWING #: 0G8890

EXPLODED VIEW: EXHAUST SYSTEM 2.4L G2**DRAWING #: 0G8890****GROUP F**

APPLICABLE TO:

ITEM	PART #	QTY.	DESCRIPTION
1	0F7366	1	MUFFLER C1
2	0F7647	1	MUFFLER SADDLE
3	0F8095	1	PIPE EXHAUST OUTLET
4	0G8614	1	EXHAUST ELBOW 2.4L G2
5	0E3257	4	SCREW HWHTF M6-1.0 X 16
6	0F7644	2	MUFFLER STRAP
7	0C6119	1	BOLT U 5/16-18 X 2-1/4
8	036434	2	BOLT U 5/16-18 X 2.09
9	036449	2	SADDLE 2 INCH
10	022129	4	WASHER LOCK M8-5/16
11	022259	4	NUT HEX 5/16-18 STEEL
12	038750	1	SCREW HHC M6-1.0 X 30 G8.8
13	0G8613	1	EXHAUST PIPE 2.4L G2
14	0F3794B	1	EXHAUST BLANKET 700MM LONG
15	022097	1	WASHER LOCK M6-1/4
16	049813	1	NUT HEX M6 X 1.0 G8 YEL CHR
17	022473	6	WASHER FLAT 1/4-M6 ZINC
18	0D2611	2	SCREW HHC 3/8-16 X 1-3/4 SS
19	085917	2	WASHER LOCK 3/8 SS
20	088775	2	WASHER FLAT 3/8 SS
21	044149	1	GASKET EXHAUST RING
22	0E8816	1	FLANGE EXHAUST 2" PIPE

GROUP G

OPTION 1 - SINGLE PHASE, R-SERIES CONTROL PANEL, 240V

LEGEND

- AR = ALTERNATOR ROTOR
- AS = ALTERNATOR STATOR
- MLCB = MAIN CIRCUIT BREAKER
- NB = NEUTRAL BLOCK

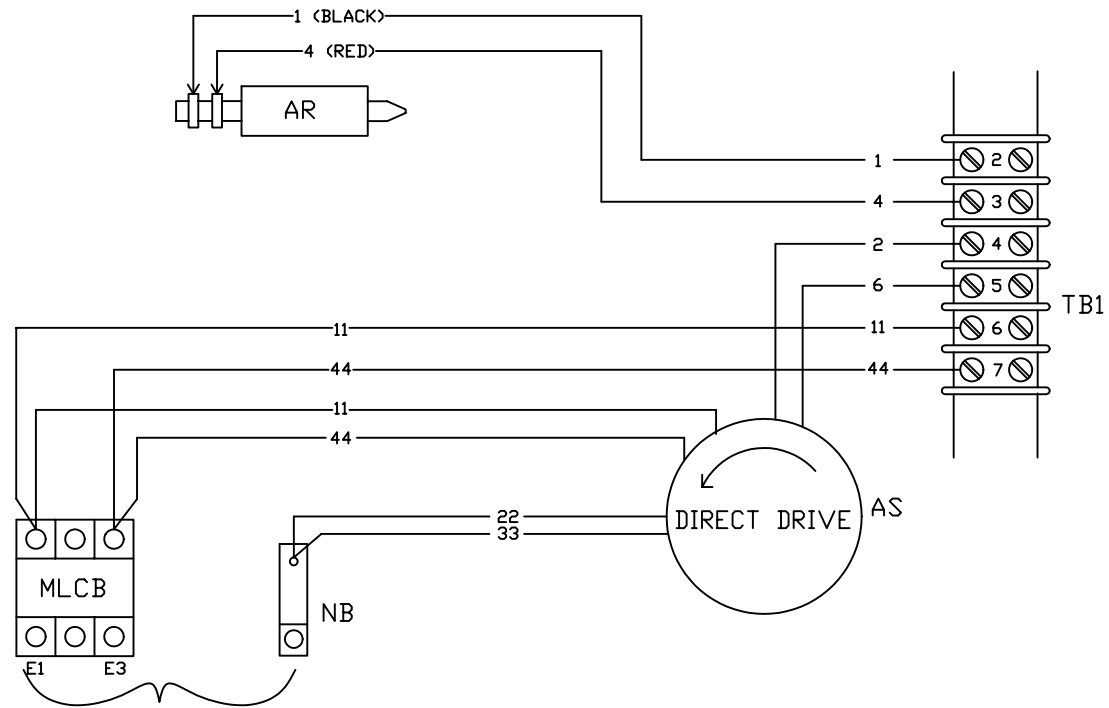

GENERATOR OUTPUT
CUSTOMER CONNECTION

- E1 - E3 = 240VAC
- E1 - NB = 120VAC
- E3 - NB = 120VAC

GROUP G

OPTION 2 - THREE PHASE, R-SERIES CONTROL PANEL, 6-WIRE 120/208V

LEGEND

- AR = ALTERNATOR ROTOR
- AS = ALTERNATOR STATOR
- MLCB = MAIN CIRCUIT BREAKER
- NB = NEUTRAL BLOCK

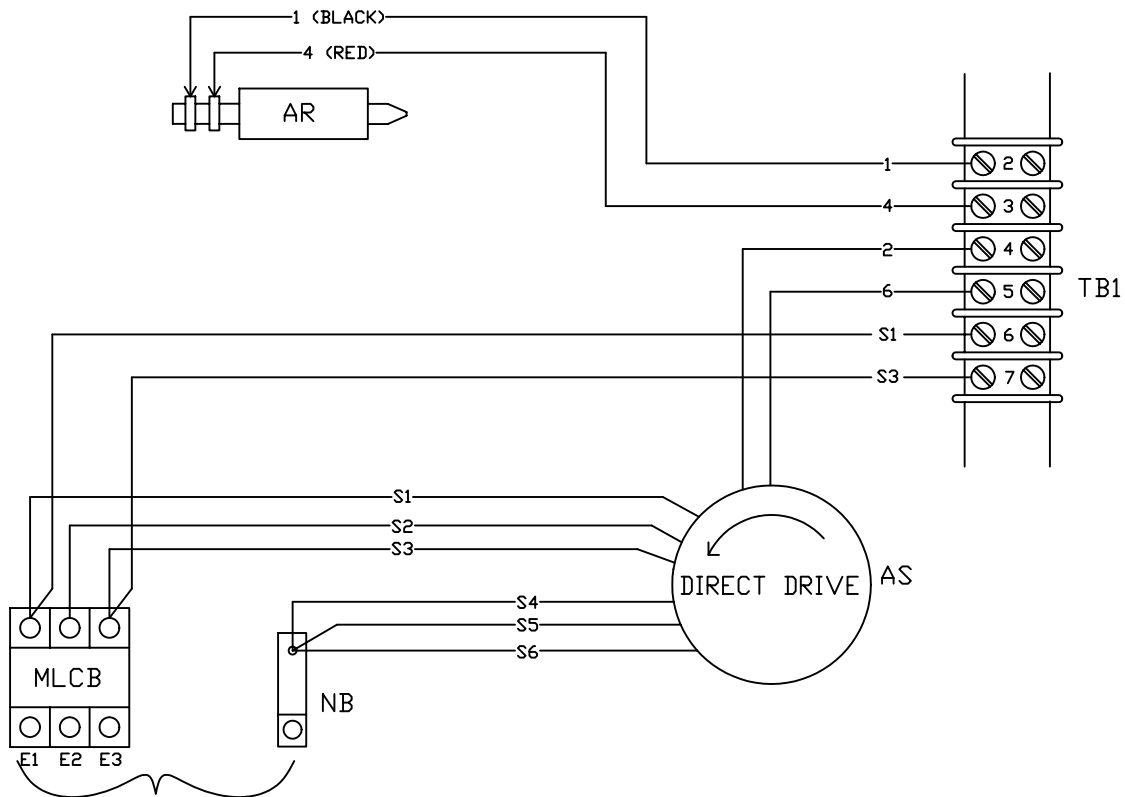

GENERATOR OUTPUT
CUSTOMER CONNECTION

E1 TO E2
E2 TO E3 *208VAC }
E1 TO E3

E1, E2, OR E3 TO NB = * 120VAC

*NOTE: THE 8th DIGIT OF THE MODEL NUMBER SPECIFIES OUTPUT VOLTAGE

"G" = 120/208VAC

OPTION 3 - THREE PHASE, R-SERIES CONTROL PANEL, 6-WIRE 277/480V

LEGEND

- AR = ALTERNATOR ROTOR
- AS = ALTERNATOR STATOR
- MLCB = MAIN CIRCUIT BREAKER
- NB = NEUTRAL BLOCK

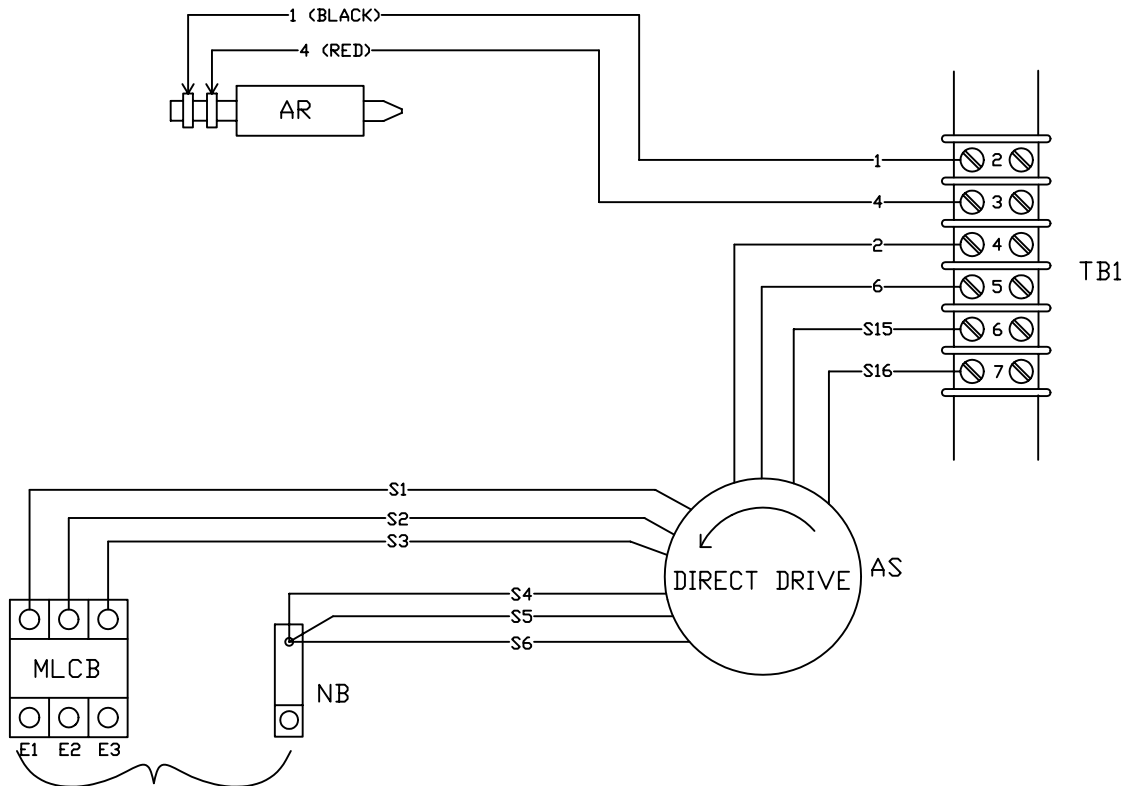

GENERATOR OUTPUT
CUSTOMER CONNECTION

E1 TO E2
E2 TO E3 *480VAC }
E1 TO E3
E1, E2, OR E3 TO NB = * 277VAC

*NOTE: THE 8th DIGIT OF THE MODEL NUMBER SPECIFIES OUTPUT VOLTAGE
"K" = 227/480VAC

OPTION 4 - THREE PHASE, R-SERIES CONTROL PANEL, 12-WIRE 120/208

LEGEND

- AR = ALTERNATOR ROTOR
- AS = ALTERNATOR STATOR
- MLCB = MAIN CIRCUIT BREAKER
- NB = NEUTRAL BLOCK

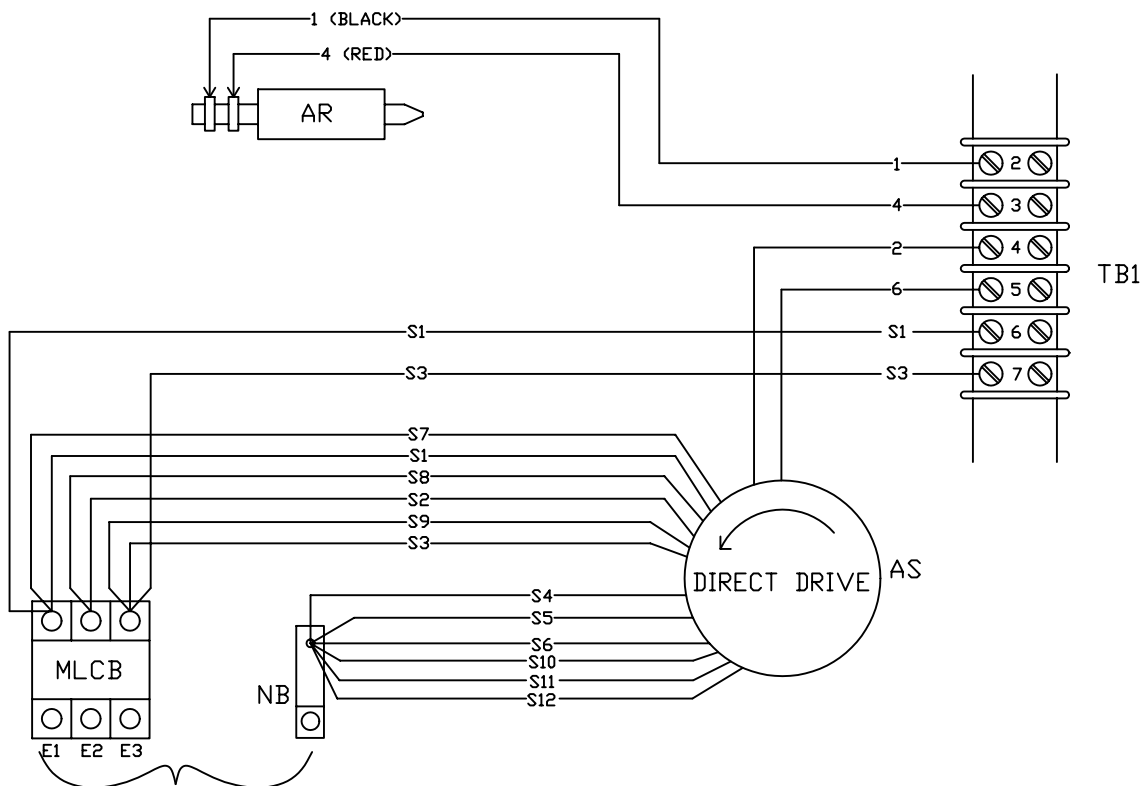

GENERATOR OUTPUT
CUSTOMER CONNECTION

E1 TO E2
E2 TO E3 *208VAC }
E1 TO E3

E1, E2, OR E3 TO NB = * 120VAC

*NOTE: THE 8th DIGIT OF THE MODEL NUMBER SPECIFIES OUTPUT VOLTAGE

"G" = 120/208VAC

GROUP G

NOTES:

- 1) MINIMUM RECOMMENDED CONCRETE PAD SIZE: 1041 (41.0") WIDE X 1892 (74 1/2") LONG. REFERENCE INSTALLATION GUIDE SUPPLIED WITH UNIT FOR CONCRETE PAD GUIDELINES.
- 2) ALLOW SUFFICIENT ROOM ON ALL SIDES OF THE GENERATOR FOR MAINTENANCE AND SERVICING. THIS UNIT MUST BE INSTALLED IN ACCORDANCE WITH CURRENT APPLICABLE NFPA 37 AND NFPA 70 STANDARDS AS WELL AS ANY OTHER FEDERAL, STATE AND LOCAL CODES FOR MINIMUM DISTANCES FROM OTHER STRUCTURES.
- 3) CIRCUIT BREAKER INFORMATION:
SEE SPECIFICATION SHEET WITHIN OWNERS MANUAL.
- 4) INSIDE STUB-UP AREA FOR AC LOAD LEAD CONDUIT CONNECTION, NEUTRAL CONNECTION, BATTERY CHARGER 120 VOLT AC (0.5 AMP MAX.) CONNECTION, ACCESS TO TRANSFER SWITCH CONTROL WIRES, AND TRANSFER SWITCH CONNECTION (IF SO EQUIPPED). REMOVE FRONT COVER FOR ACCESS.
- 4A) ONE 1-1/2" NEMA ELECTRICAL KNOCKOUT AND TWO 1/2" NEMA ELECTRICAL KNOCKOUTS PROVIDED FOR OUTSIDE AC LOAD CONDUIT CONNECTION, NEUTRAL CONNECTION, BATTERY CHARGER 120 VOLT AC (0.5 AMP MAX.) CONNECTION, ACCESS TO TRANSFER SWITCH CONTROL WIRES, AND TRANSFER SWITCH CONNECTION (IF SO EQUIPPED). REMOVE FRONT COVER FOR ACCESS.
- 5) REFERENCE OWNERS MANUAL FOR LIFTING WARNINGS.
- 6) REMOVE LIFT-OFF ENCLOSURE TO ACCESS EXHAUST MUFFLER.

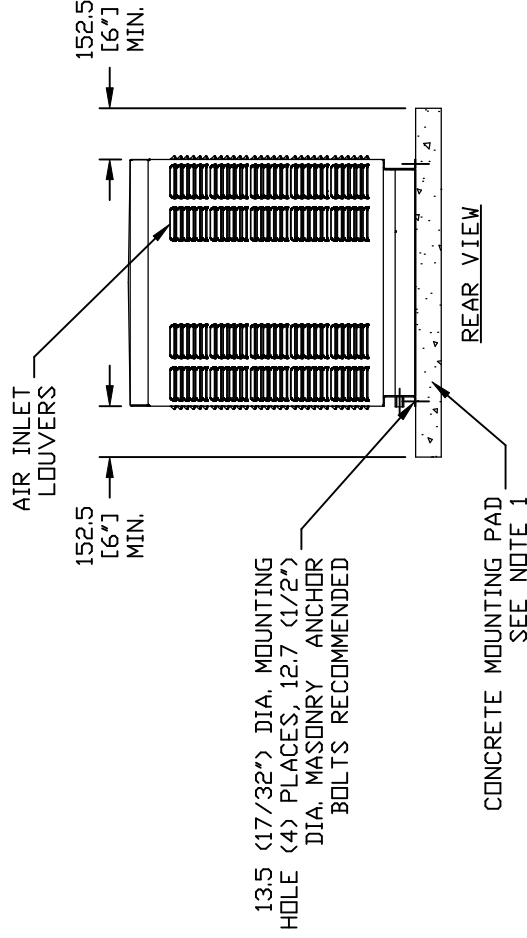

WEIGHT DATA				
ENGINE/KW	ENCLOSURE MATERIAL	WEIGHT (GENSET ONLY) (KG [LBS])	WEIGHT (SHIPPING CARTON/SKID) (GENSET, SKID, & CARTON) (KG [LBS])	SHIPPING WEIGHT (GENSET, SKID, & CARTON) (KG [LBS])
2. 4L/22KW	ALUMINUM	383 [843]	30 [66]	413 [909]
2. 4L/27KW	ALUMINUM	405 [891]		434 [957]

**EXPLODED VIEW:
INSTALLATION DRAWING C1 CPL
DRAWING #: 0G9370**

GROUP G

SERVICE ITEM ACCESSIBILITY CHART

SERVICE ITEM	ACCESS
OIL FILL CAP	THRU RIGHT DOOR
OIL DIP STICK	THRU RIGHT DOOR
OIL FILTER	THRU RIGHT DOOR
OIL DRAIN HOSE	THRU LEFT DOOR
RADIATOR DRAIN HOSE	THRU LEFT DOOR
AIR CLEANER ELEMENT	THRU LEFT DOOR
SPARK PLUGS	THRU LEFT DOOR
MUFFLERS	SEE NOTE 6
FAN BELT	THRU RIGHT DOOR
BATTERY	THRU LEFT DOOR

REFERENCE OWNERS MANUAL
FOR PERIODIC REPLACEMENT
PART LISTINGS

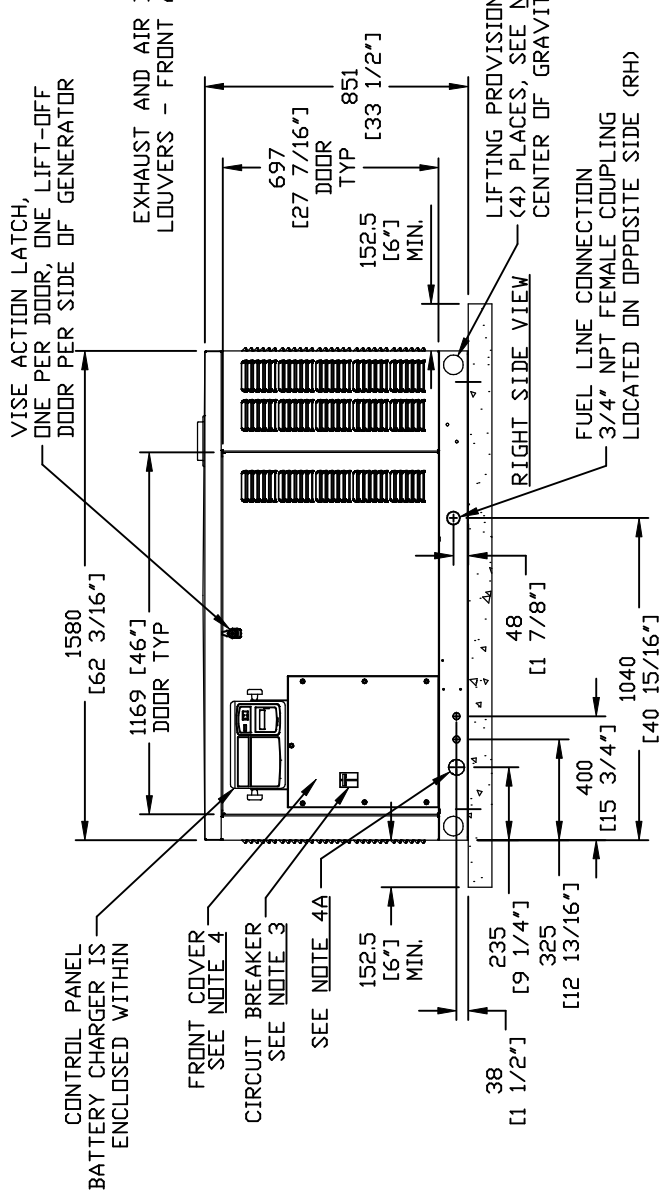
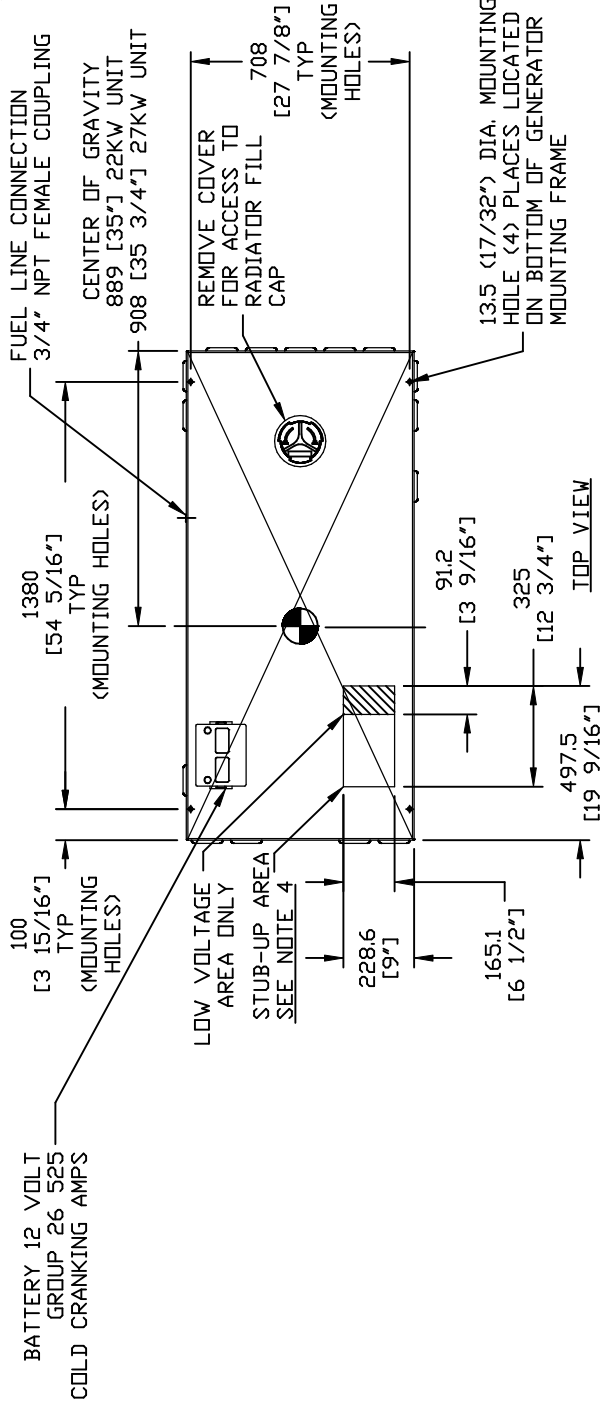

EXPLODED VIEW:
INSTALLATION DRAWING C1 CPL
DRAWING #: 0G9370

GROUP G

CONTROL PANEL LEGEND:
 AVR - AUTOMATIC VOLTAGE REGULATOR
 BCH - BATTERY CHARGER
 BR1 - DIODE (FIELD BOOST)
 CB2 - CIRCUIT BREAKER (EXCITATION)
 CC - CROSSOVER CONNECTOR
 F1 - FUSE, BAT POWER (15A ATO TYPE)
 HM - HOUR METER
 J2 - CONNECTOR 2 (ON PCB)
 R4 - FIELD BOOST RESISTOR 15 OHM
 RL1 - RELAY 1 (START RELAY)
 RL2 - RELAY 2 (ENGINE RUN)
 SW1 - AUTO/OFF/MANUAL SWITCH
 SW2 - SET EXERCISER SWITCH
 TB - TERMINAL BLOCK
 TR1 - TRANSFORMER (6VA UTIL/16 VAC)

NOTE: ALL WIRES ARE 18 AWG
 UL LISTED UNLESS OTHERWISE
 NOTED AS SHOWN:



CUSTOMER CONNECTION & ALTERNATOR LEGEND:
 BA - BRUSH ASSEMBLY (GENERATOR)
 CB1 - MAINLINE CIRCUIT BREAKER
 NB - NEUTRAL BLOCK
 TB-BC - BATTERY CHARGER TERMINAL BLOCK
 TBG - GTS CONNECT TERMINAL BLOCK
 TBR - RTS CONNECT TERMINAL BLOCK

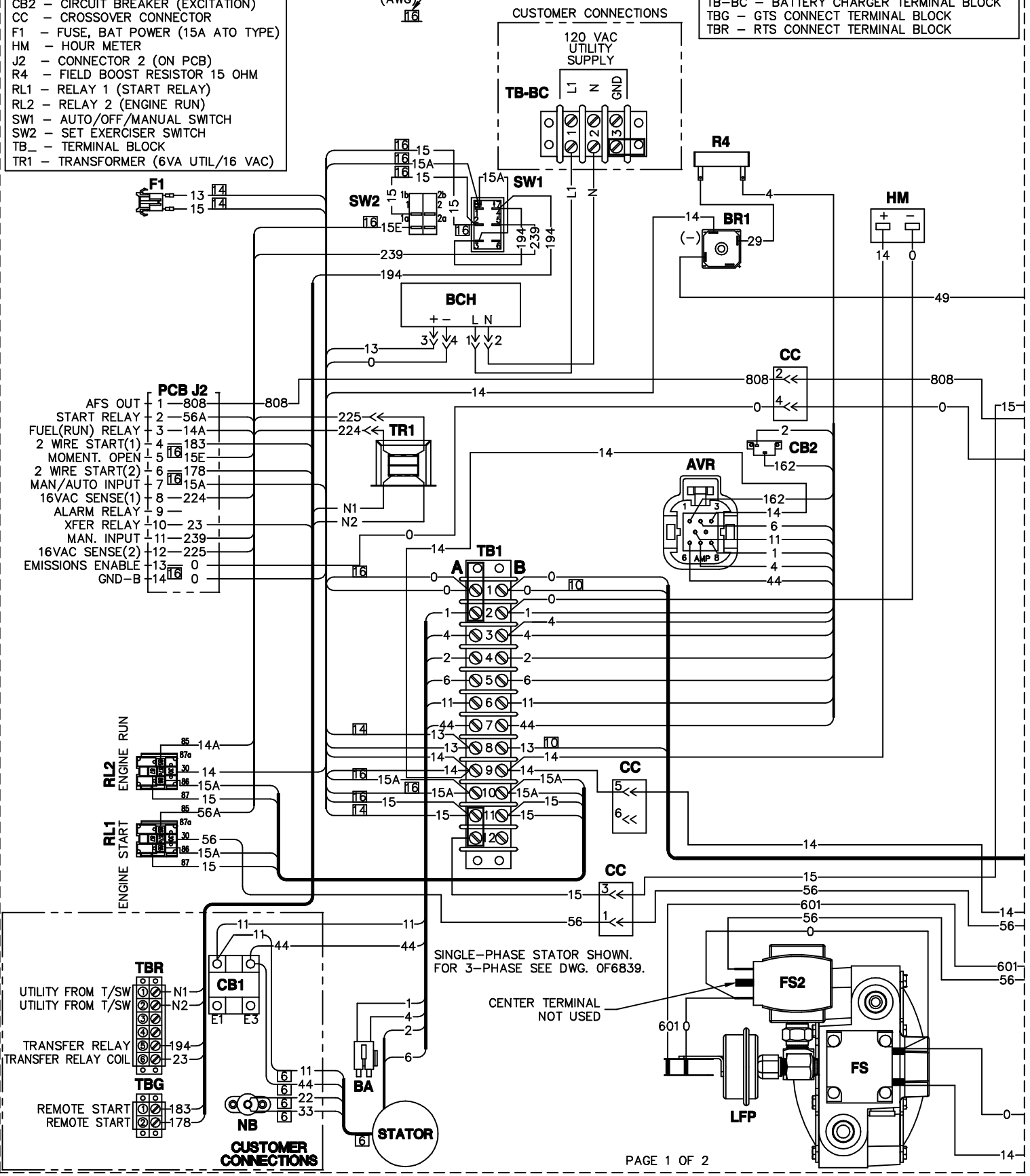

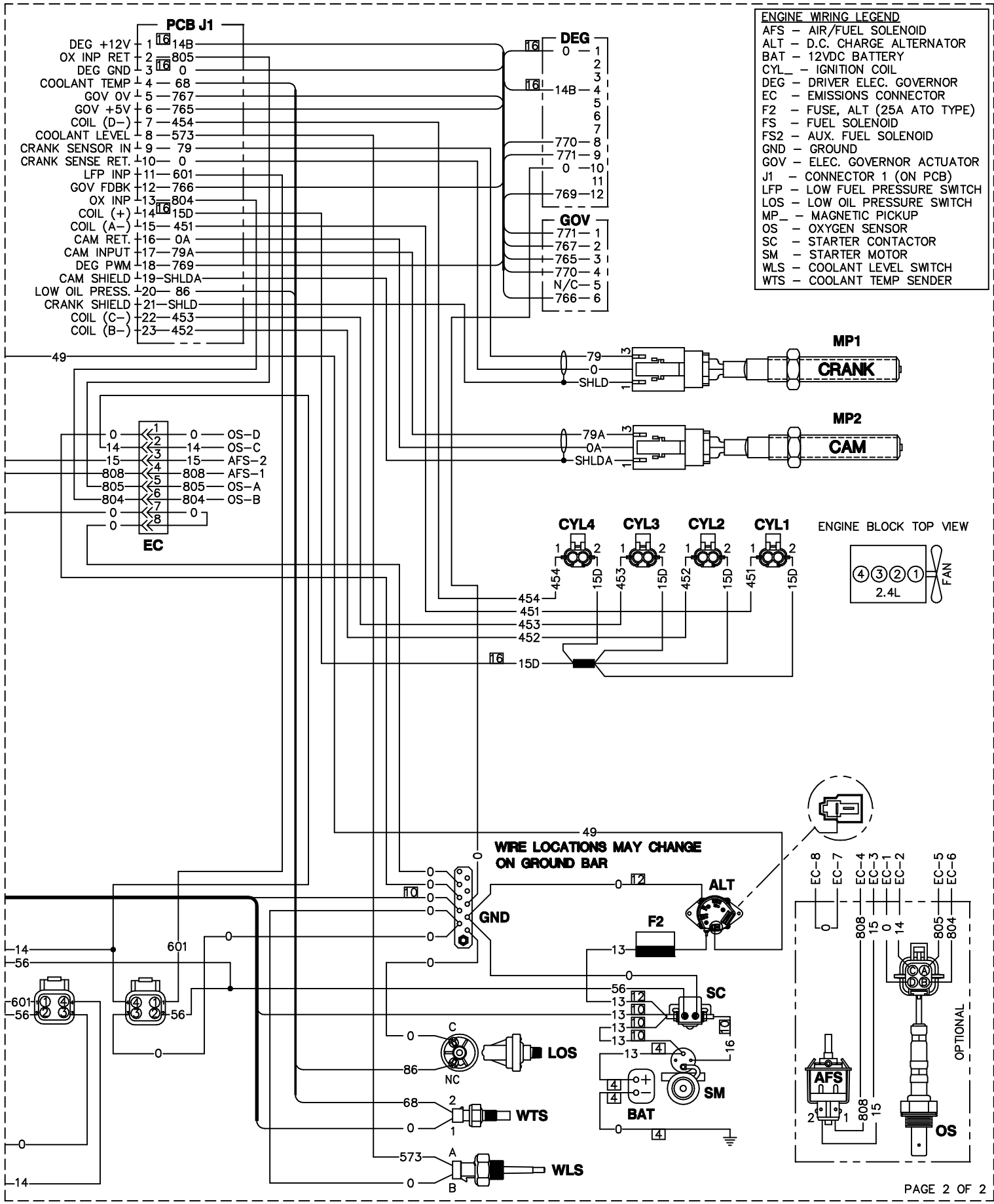

CONTROL PANEL LEGEND:

- AVR - AUTOMATIC VOLTAGE REGULATOR
- BCH - BATTERY CHARGER
- BR1 - DIODE (FIELD BOOST)
- CB2 - CIRCUIT BREAKER (EXCITATION)
- F1 - FUSE BAT POWER (15A ATO TYPE)
- HM - HOUR METER
- J2 - CONNECTOR 2 (ON PCB)
- R4 - FIELD BOOST RESISTOR 15 OHM
- RL1 - RELAY 1 (START RELAY)
- RL2 - RELAY 2 (ENGINE RUN)
- SW1 - AUTO/OFF/MANUAL SWITCH
- SW2 - SET EXERCISER SWITCH
- TR1 - TRANSFORMER (6VA UTIL/16 VAC)

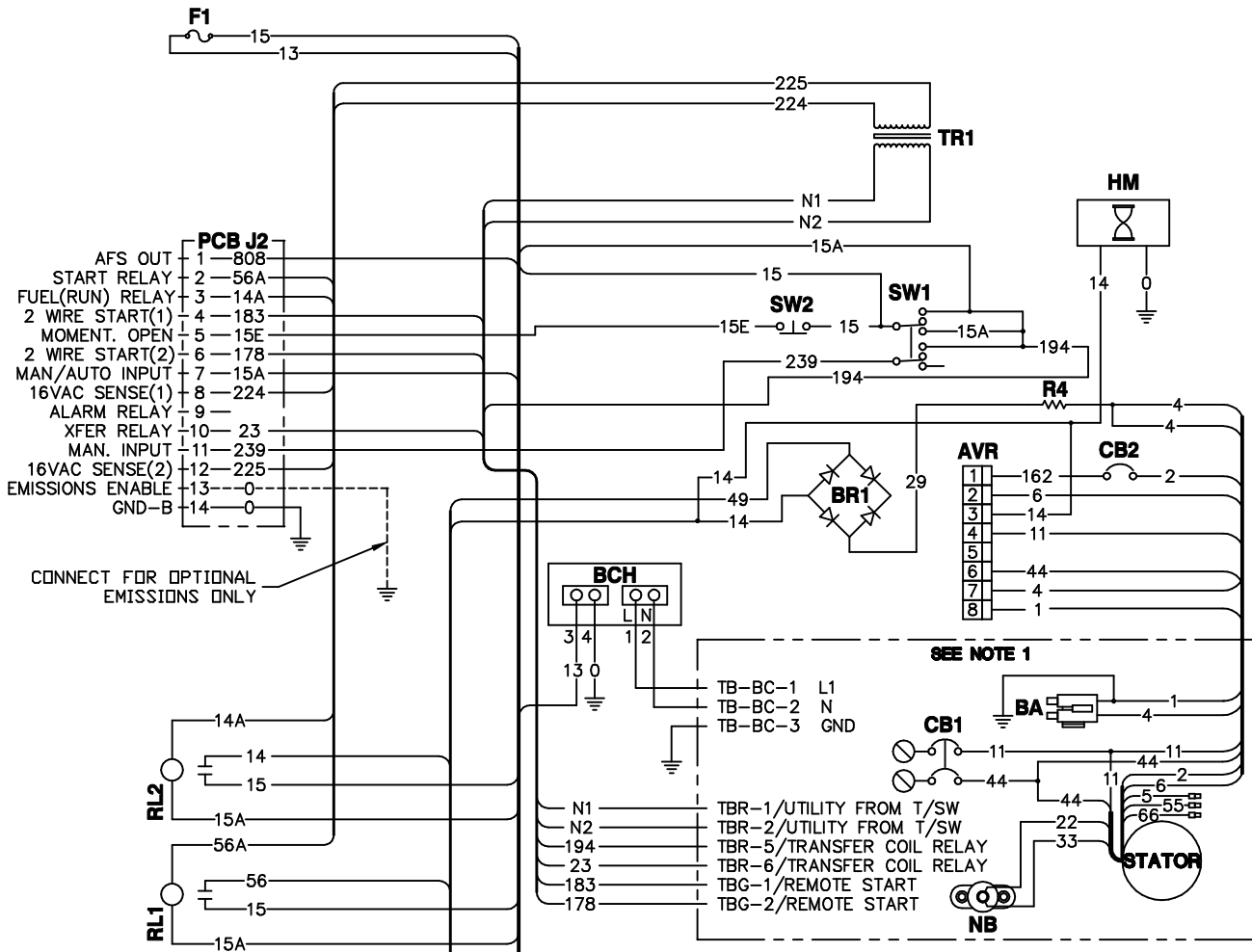

NOTE 1: WIRING SHOWN FOR CB1, NB, BA AND STATOR IS TYPICAL FOR SINGLE PHASE. FOR 3-PHASE, SEE DWG #0F6B39.

CUSTOMER CONNECTION & ALTERNATOR LEGEND:
 BA - BRUSH ASSEMBLY (GENERATOR)
 CB1 - MAINLINE CIRCUIT BREAKER
 NB - NEUTRAL BLOCK
 TB-BC - BATTERY CHARGER TERMINAL BLOCK
 TBG - GTS CONNECT TERMINAL BLOCK
 TBR - RTS CONNECT TERMINAL BLOCK

ENGINE WIRING LEGEND	
AFS	- AIR/FUEL SOLENOID
ALT	- D.C. CHARGE ALTERNATOR
BAT	- 12VDC BATTERY
CYL	- IGNITION COIL
DEG	- DRIVER ELEC. GOVERNOR
F2	- FUSE ALT (25A ATO TYPE)
FS	- FUEL SOLENOID
FS2	- AUX. FUEL SOLENOID
GOV	- ELEC. GOVERNOR ACTUATOR
J1	- CONNECTOR 1 (ON PCB)
LFP	- LOW FUEL PRESSURE SWITCH
LOS	- LOW OIL PRESSURE SWITCH
MP	- MAGNETIC PICKUP
OS	- OXYGEN SENSOR
SC	- STARTER CONTACTOR
SM	- STARTER MOTOR
SP	- SPARK PLUG
WLS	- COOLANT LEVEL SWITCH
WTS	- COOLANT TEMP SENDER

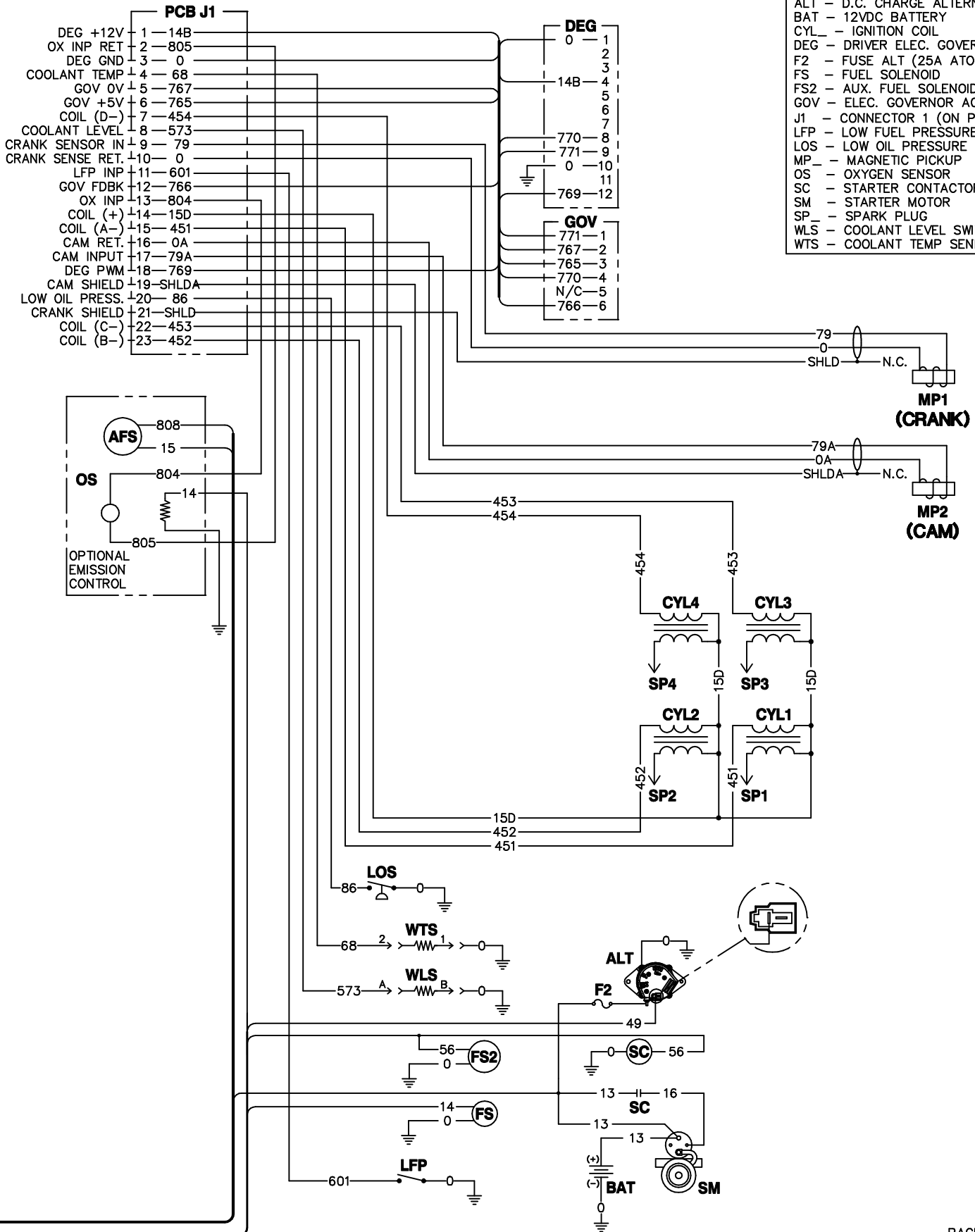

GROUP G

NOTE: ITEMS MARKED BY * ARE PART OF WIRE HARNESS.

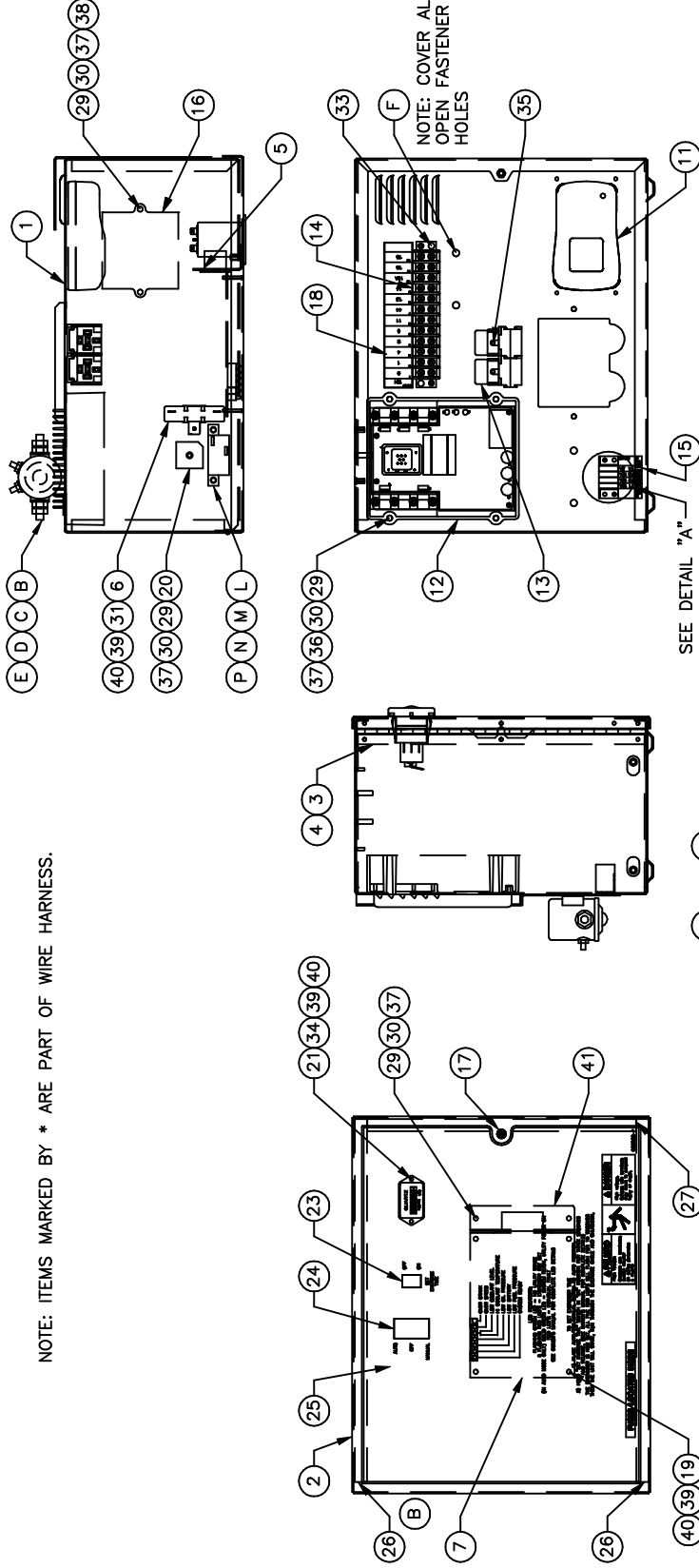

MODEL RATING	ITEM L RATING	ITEM L P/N
22KW/27KW 1φ	3A	054502
22KW/27KW 3φ	6A	048505
36KW 1φ/3φ	7A	048467
17.6KW/21.6KW 1φ 50Hz	5A	048512

EXPLODED VIEW:
R-200C 1800 RPM 2.4L
DRAWING #: 0H1433D

APPLICABLE TO:

ITEM	PART #	QTY.	DESCRIPTION
COMPONENTS INCLUDED IN 0H1433E			
1	0F1823B	1	ENCL HSB CONTROL PANEL
2	0F3078BST06	1	COVER CONTROL PANEL R-200B
3	0F2606	1	HINGE CONTINUOUS H-PANEL
4	036261	7	RIVET POP .125 X .275 SS
5	0E7358	4	SCREW PPH HI-LO #4-24 X 3/8
6	052777	1	WASHER FLAT M3
7	0H1176A	1	ASSY PCB R-200C CNTRL 1800 RPM
*8	0F1262	REF.	HOLDER FUSE WICKMANN 178.6150
*9	0F1263	REF.	ADPTR RH SIDE WICKMANN 178.6191
*10	0F1264	REF.	ADPTR LH SIDE WICKMANN 178.6192
11	0G8023A	1	BATC 13.4VDC 2.5A W/4POS PLUG
12	0G2885	1	ASSY PCB HI-PWR VOLTAGE RGLTR
13	0E6875A	2	RELAY 12VDC C FORM W/DIODE
*14	055911	REF.	BLOCK TERM 20A 12 X 6 X 1100V
15	0F5459	1	DECAL CPL CNT PNL FUSES
16	0E3161	1	ASSY PCB BOSCH GOV DRMR
17	0G3648	1	M5X0.8 CAPTIVE PANEL KNLD HD
18	0F5462	1	DECAL CPL 3.9L TB1
19	0A5062J	4	SPACER 9.5H 3.2 ID
20	029673	1	DIO BRIDGE 25A 600V
21	0C1457A	1	HOUR METER 10-80VDC
22	0F1958	1	PLATE HARNESS CLAMP
23	082573	1	SWITCH RKR DPST 125V SPD
24	0E4494	1	SWITCH RKR DPDT ON-OFF-ON
25	0G8997	1	DECAL CONTROL FLEX R-200B
26	0F6305	2	SEAL COVER 3.18X12.7X382
27	0F6305A	1	SEAL COVER 3.18X12.7X283
28	0F5886	2	SCREW HHPM M5-0.8 X 12
29	051713	11	WASHER FLAT M5
30	049226	11	WASHER LOCK M5
31	0F5752F	1	RES WW 15R 5% 25W QK CONN
32	0F5884	2	SCREW PHTT M3.5-0.6 X 10
33	0F5896	2	SCREW PHTT M3.5-0.6 X 16
34	074076	2	SCREW PHM M3-0.5 X 10 BLACK
35	0C3990	2	SCREW PHTT M4-0.7 X 10 ZYC
36	080823	4	SCREW PPHM M5-0.8 X 50 ZNC
37	051716	9	NUT HEX M5-0.8 G8 YEL CHR
38	079224	2	SCREW PPHM M5-0.8 X 30 SS
39	043182	7	WASHER LOCK M3
40	051714	7	NUT HEX M3-0.5 G8 YEL CHR
41	0F3192	1	SUPPORT ANGLE PCB
42	0E7403C	1	FUSE ATO TYPE 15 AMP (BLUE)
43	0G9056	1	HARN CTRL PNL R-200B 2.4L/4.2L (NOT SHOWN)
COMPONENTS INSTALLED PER THIS DRAWING			
A	056739	1	RELAY SOLENOID 12VDC PNL MNT
B	022287	2	SCREW HHC 1/4-20 X 3/4 G5
C	022473	4	WASHER FLAT 1/4-M6 ZINC
D	022097	2	WASHER LOCK M6-1/4
E	022127	2	NUT HEX 1/4-20 STEEL
F	0F6145	A/R	SEAL WEATHER .45"DIA
G	0F2627A	1	COVER CONTROL PANEL SIDE
H	091526	4	SCREW PPHM M5-0.8 X 12 ZNC
J	049226	4	WASHER LOCK M5
K	051713	4	WASHER FLAT M5
L	SEE CHART	1	DPE BREAKER
M	052777	2	WASHER FLAT M3
N	043182	2	WASHER LOCK M3
P	051714	2	NUT HEX M3-0.5 G8 YEL CHR

NOTE: ITEMS MARKED BY * ARE PART OF WIRE HARNESS.

